

INSTALLATION INSTRUCTIONS



PRO-SERIES FRONT BUMPER
APPLICATION:
2022-2023 TOYOTA TUNDRA
PART NUMBER:
58-411285

CONTENT			
ITEM	QUANTITY	DESCRIPTION	TOOLS NEEDED
1	1	PRO-SERIES FRONT BUMPER	FLAT HEAD SCREWDRIVER
2	1	SKID PLATE	
3	1	DRIVER BRACKET	UTILITY KNIFE
4	1	PASSENGER BRACKET	RATCHET
5	1	DRIVER SUPPORT FRAME BRACKET	TORQUE WRENCH
6	1	PASSENGER SUPPORT FRAME BRACKET	PRYBAR
7	1	DRIVER SIDE OE BUMPER SUPPORT STRAP	ALLEN WRENCH
8	1	PASSENGER SIDE OE SUPPORT STRAP	10MM SOCKET
9	1	SKID PLATE BRACKET	10MM WRENCH
10	1	EDGE TRIM	18MM SOCKET
11	2	M12 BOLT PLATE	18MM WRENCH
12	4	M6 FLAT WASHERS	
13	2	M6 HEX NYLON NUT	
14	2	M6 HEX BOLT	
15	4	M8 BUTTON HEAD BOLT	
16	4	M8 SERRATED FLANGE NUT	
17	4	M8 FLAT WASHER	
18	2	M12 LONG HEX BOLT	
19	32	M12 SHORT HEX BOLT	
20	36	M12 SERRATED FLANGE HEX NUT	
21	2	M12 SPLIT LOCK WASHER	
22	62	M12 FLAT WASHER	

ANTI-SEIZE LUBRICANT MUST BE USED ON ALL STAINLESS STEEL FASTENERS TO PREVENT THREAD DAMAGE AND GALLING

Item 1

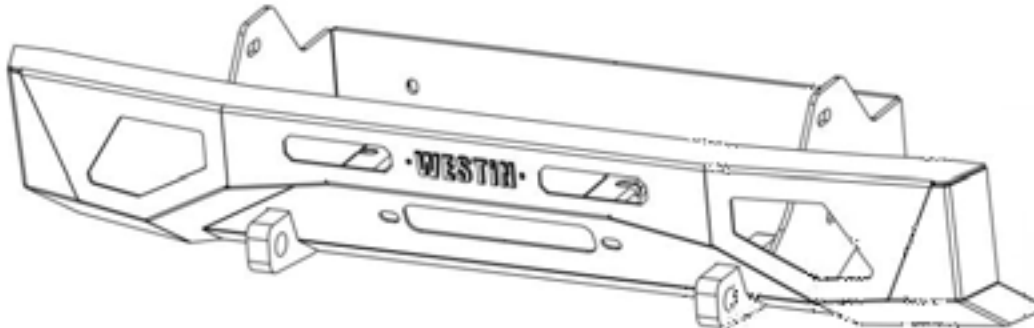

Item 2

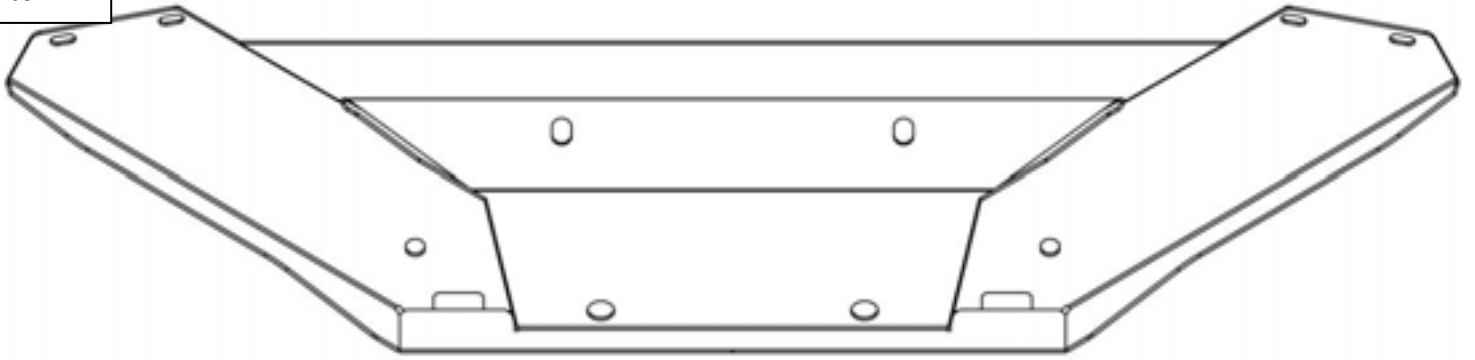

Item 3

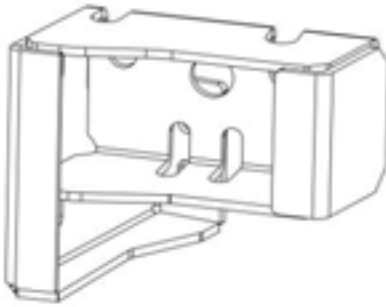

Item 4



Item 5

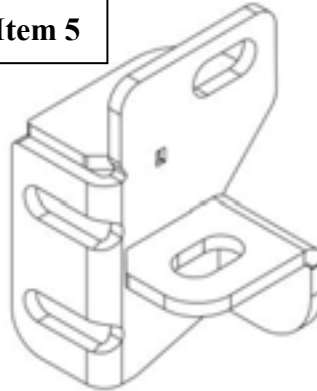

Item 6

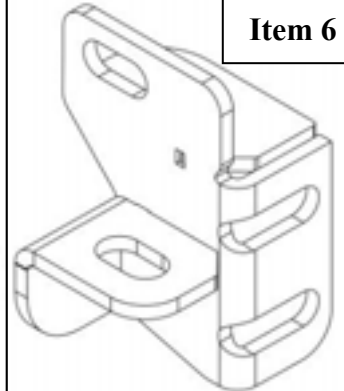

Item 7

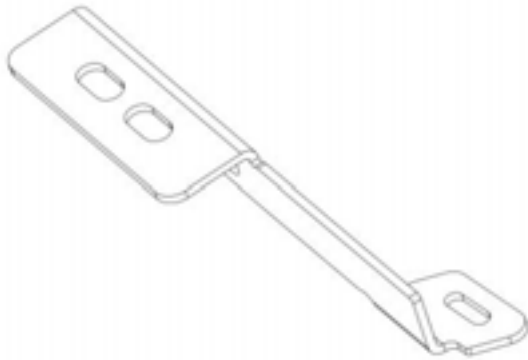

Item 8

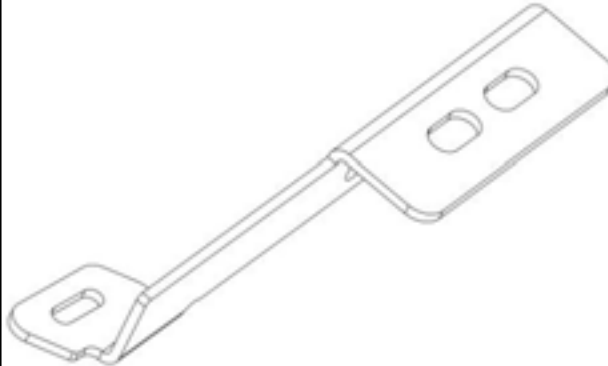

Item 9



Item 10

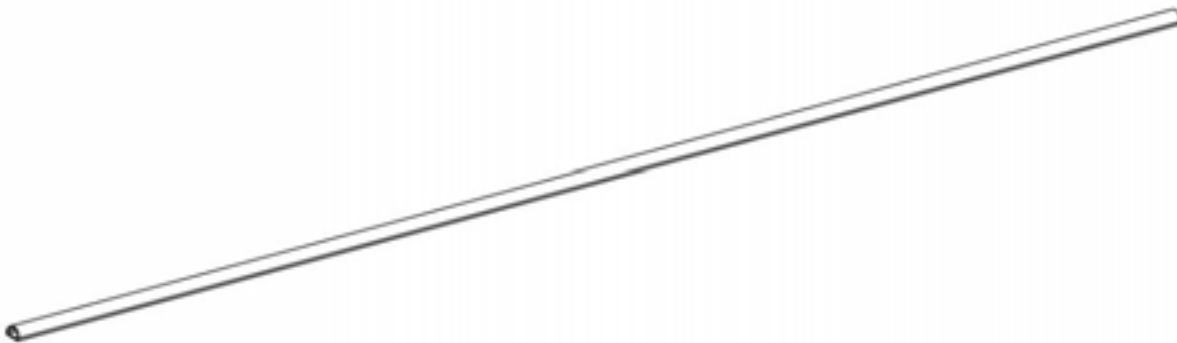

Item 11



PROCEDURE

1. Remove contents from box, verify if all parts listed are present and free from damage.
Carefully read and understand all instructions before attempting installation.
Failure to identify damage before installation could lead to a rejection of any claim.

OE Bumper Removal

2. Remove the bolts that are located on the top of the grille, attached to the radiator support. See **Figure 1** for reference.
3. Remove the plastic clips and the electrical connectors that are located on the driver and passenger side of the front bumper. See **figure 2 & 3** for reference.
4. Remove the bolts and plastic clips that are located by the fenders and on the bottom of the front bumper
5. Remove the fender flares and using a flat head screwdriver pop out the side of the front bumper. Repeat on the driver side. See **Figure 4 & 5** for reference.
6. Continue by pulling the front bumper assembly off the truck. Some force will be needed

Figure 1

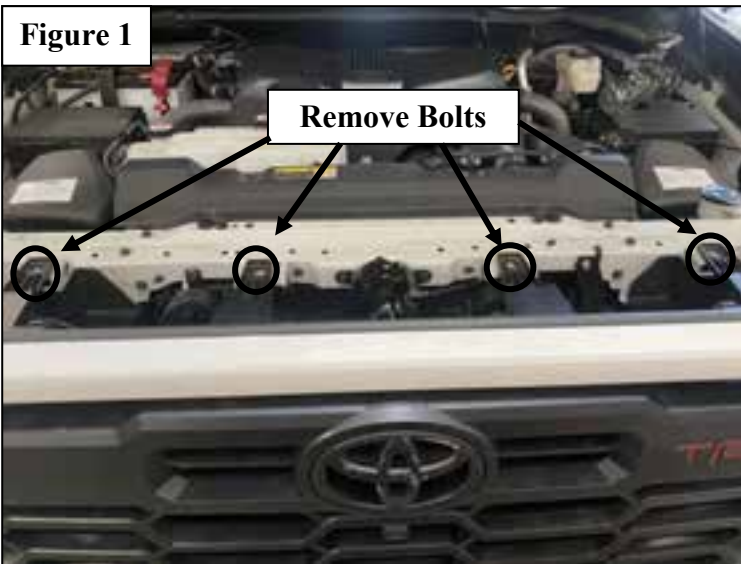

Figure 2

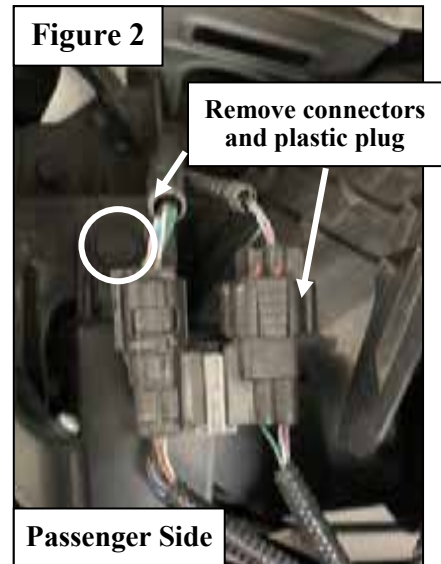

Figure 3



Figure 4

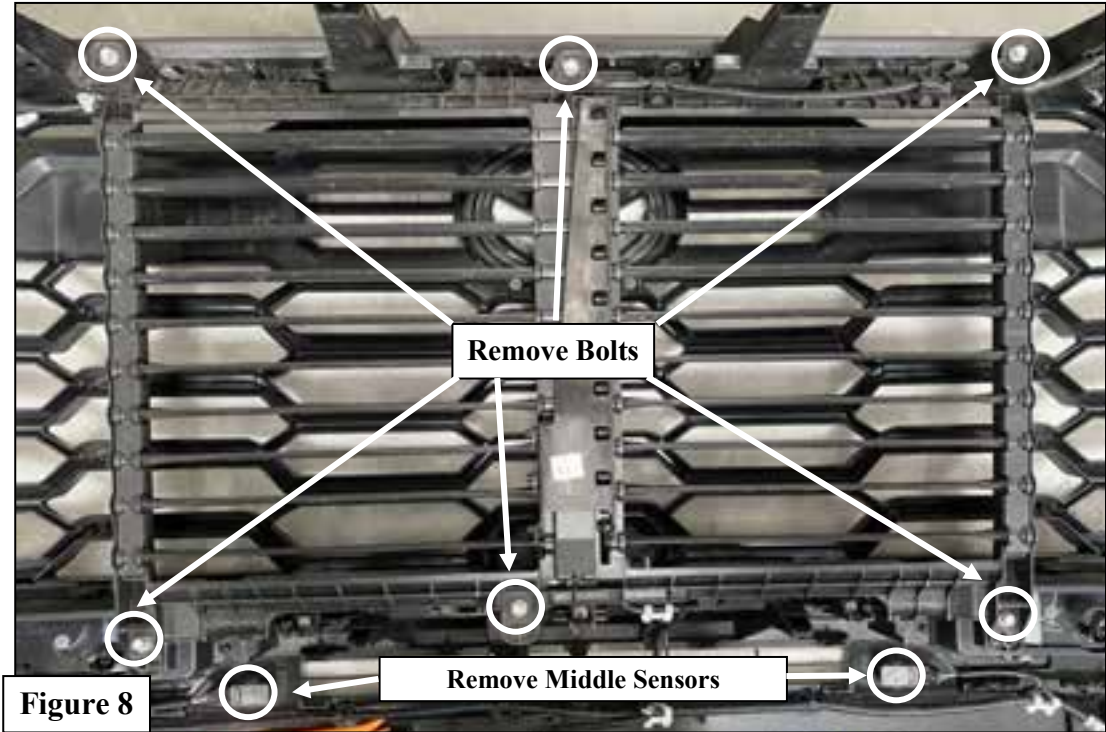
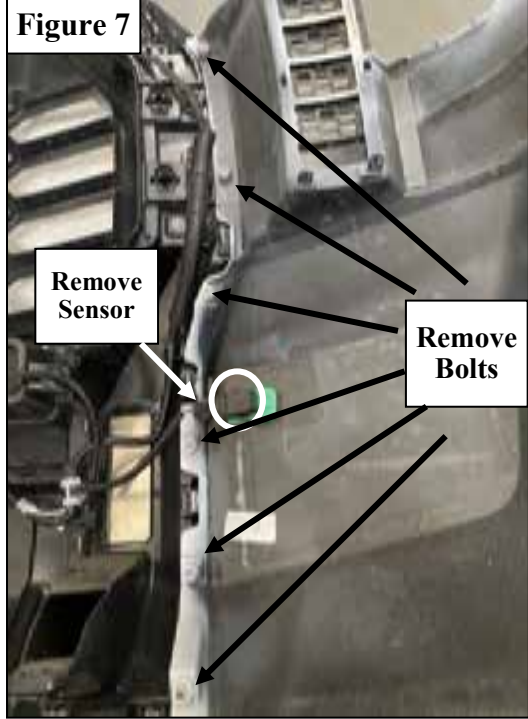
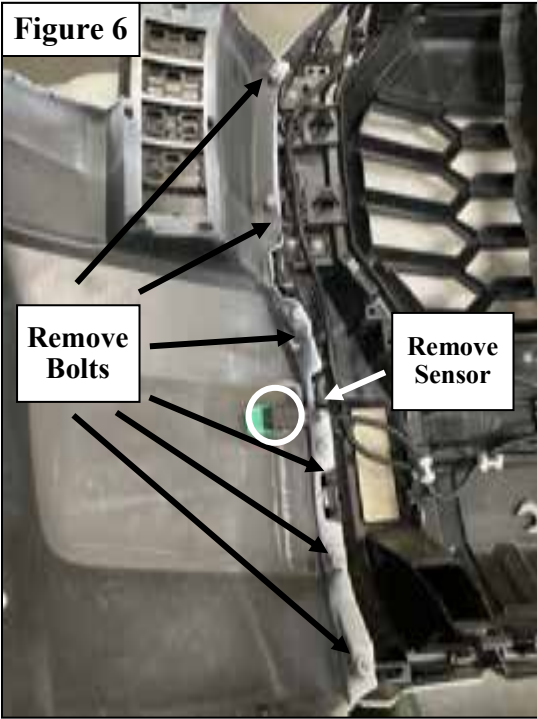

Figure 5



OE Bumper Disassembly and Trimming

6. Cautiously disconnect all four front parking sensors attached on the front bumper. See **Figure 6, 7, & 8** for reference. **NOTE:** Make sure to cautiously disconnect the sensor and remember the location and orientation to prevent any malfunctions.
7. To begin to disassemble the front bumper, start by removing the left and the right side of the bumper which is held on by 6 screws. See **Figure 6 & 7** for reference. **NOTE:** The wire harness will be removed as the front bumper is disassembled along the way.
8. Remove the bolts and wire connector on the top right that hold the active shutters. See **Figure 8** for reference.



9. Proceed by removing the screws located all around the border of the front bumper. See **Figure 9, 10, & 11** for reference.
10. Begin removing the plastic clips all along the edge of the front bumper. This will remove the top trim piece of the assembly. See **Figure 9, 10, & 11** for reference.
11. To remove the front gloss piece of the grille, remove the plastic clips. See **Figure 9, 10, & 11** for reference.
12. Begin removing the plastic clips that holds the wire harness to disassemble the front bumper assembly

Figure 9

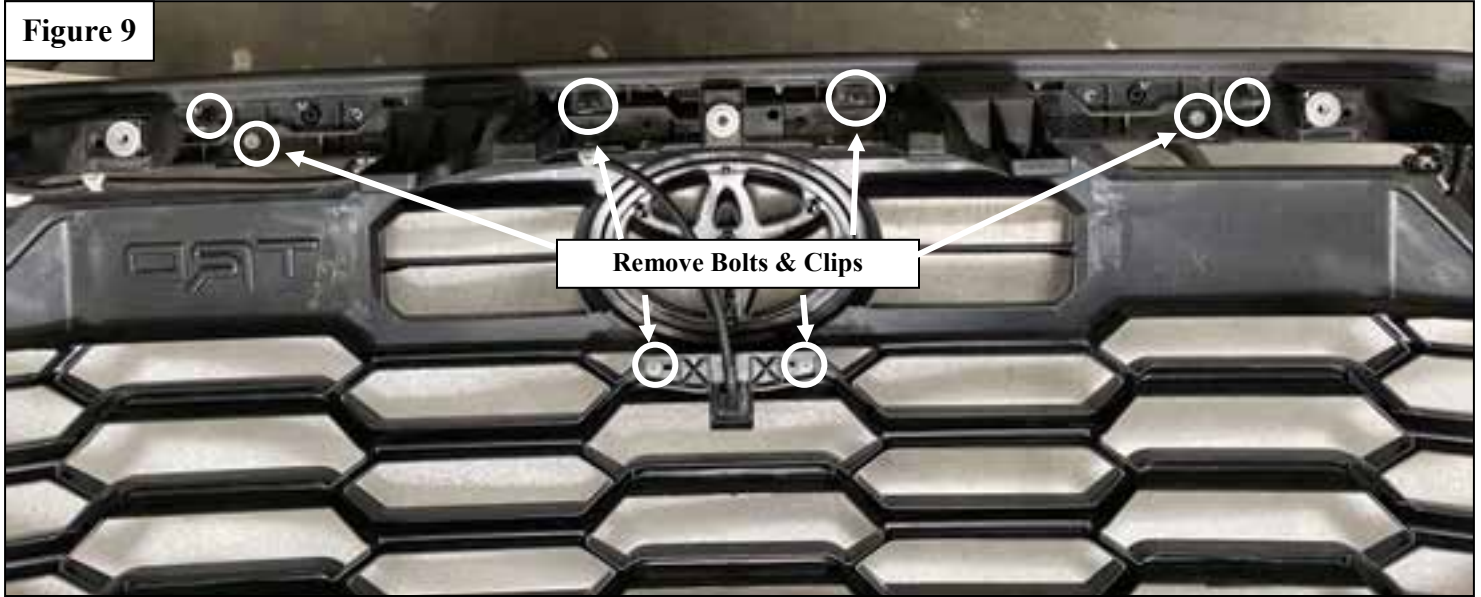

Figure 10



Figure 11



13. Carefully disconnect and remove the bolts that hold the cruise control sensor. See **Figure 12** for reference. **NOTE:** When handling the sensor make sure to place the sensor in a safe space to prevent any malfunction.
14. Disconnect the two wires that are connected to the fog lights. Continue to take out any clips that are holding the wire harness together. See **Figure 13** for reference.
15. Continue to remove the last two pieces of the assembly by removing the plastic clips. See **Figure 13** for reference.

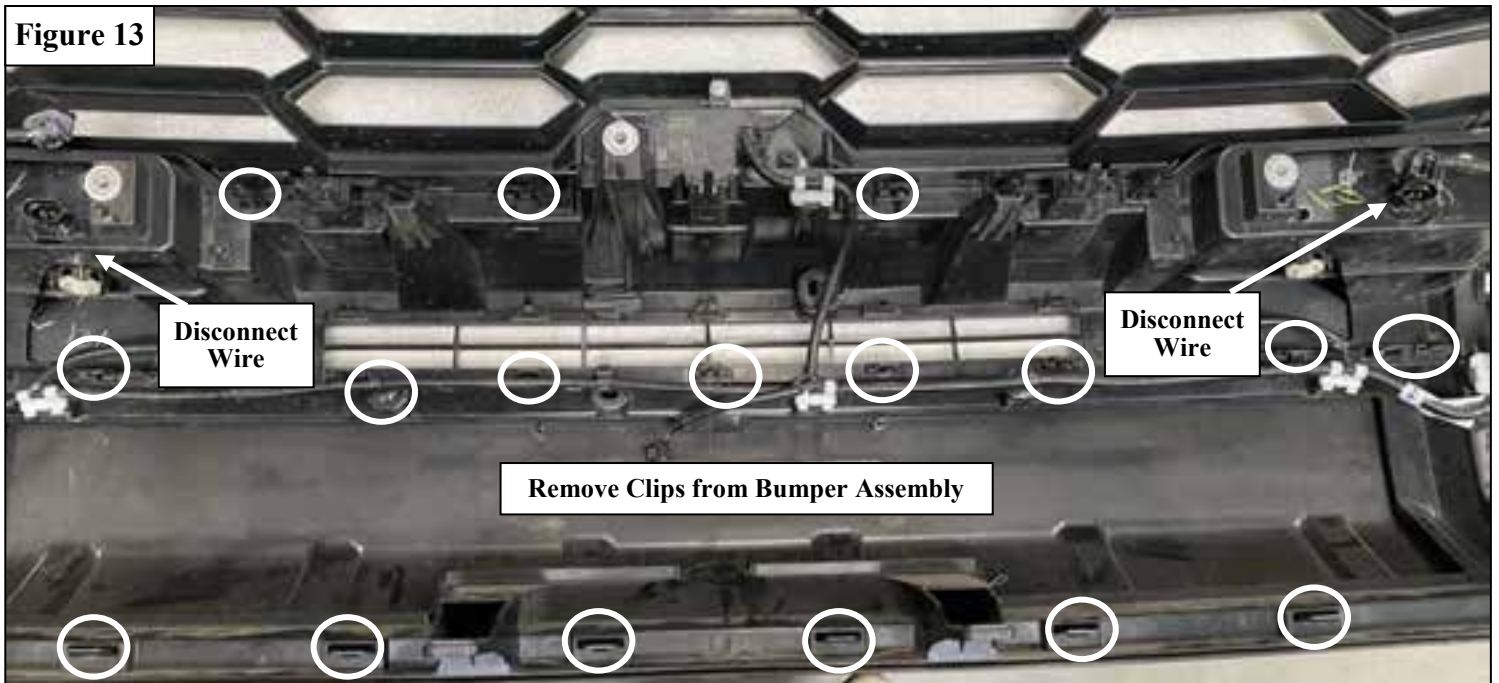
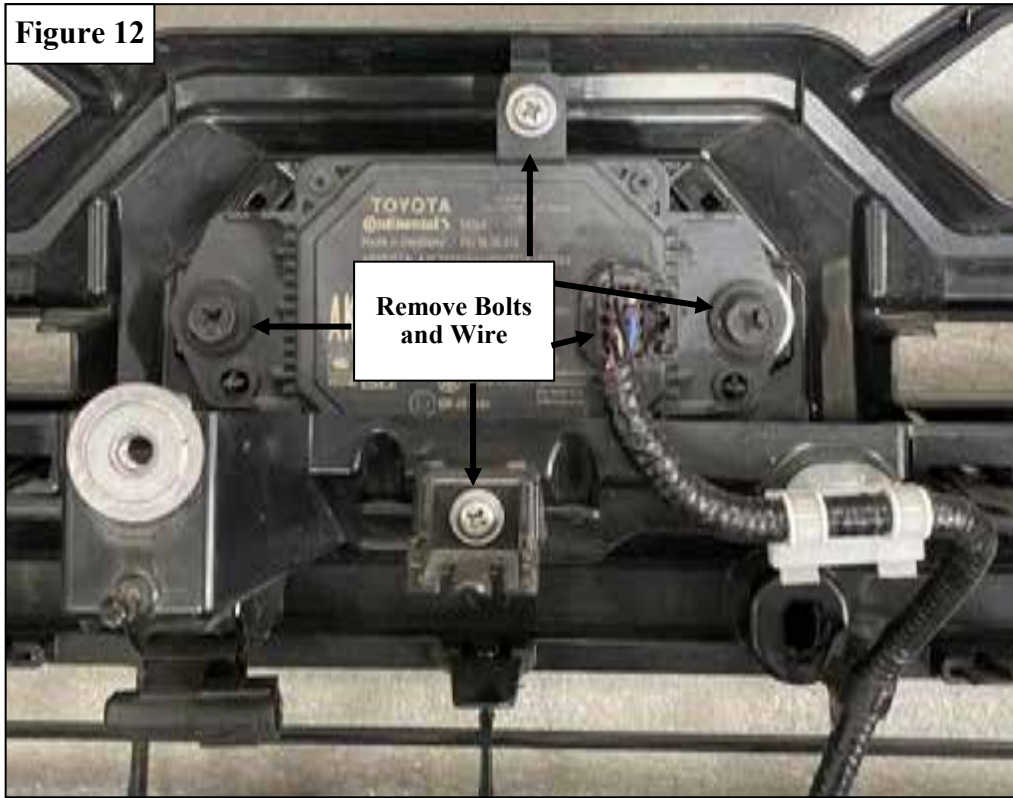

16. Prep the location that is located on both the left and right side of the assembly piece. See **Figure 14 & 15** for reference.
17. Trim the center of the assembly piece. See **Figure 16, 17, & 18** for Reference.
18. Once finished reassemble the front bumper. **NOTE:** *Cautiously install the front parking sensors as they were at the beginning of the disassembly. Cautiously install the cruise control to prevent any accidents.*

Figure 14



Figure 15

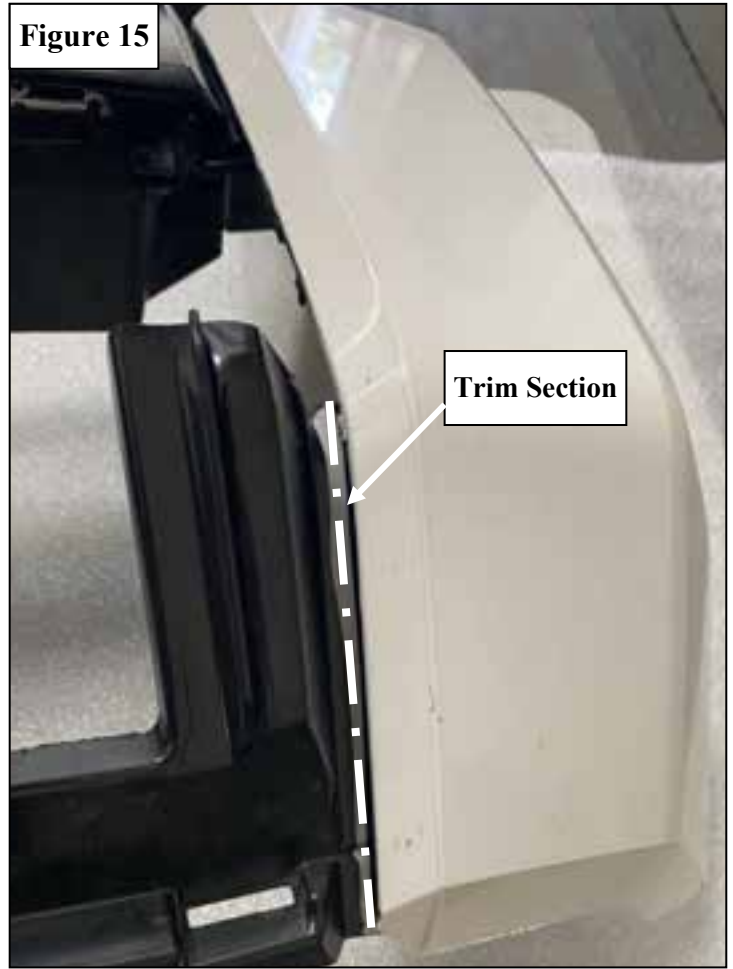

Figure 16

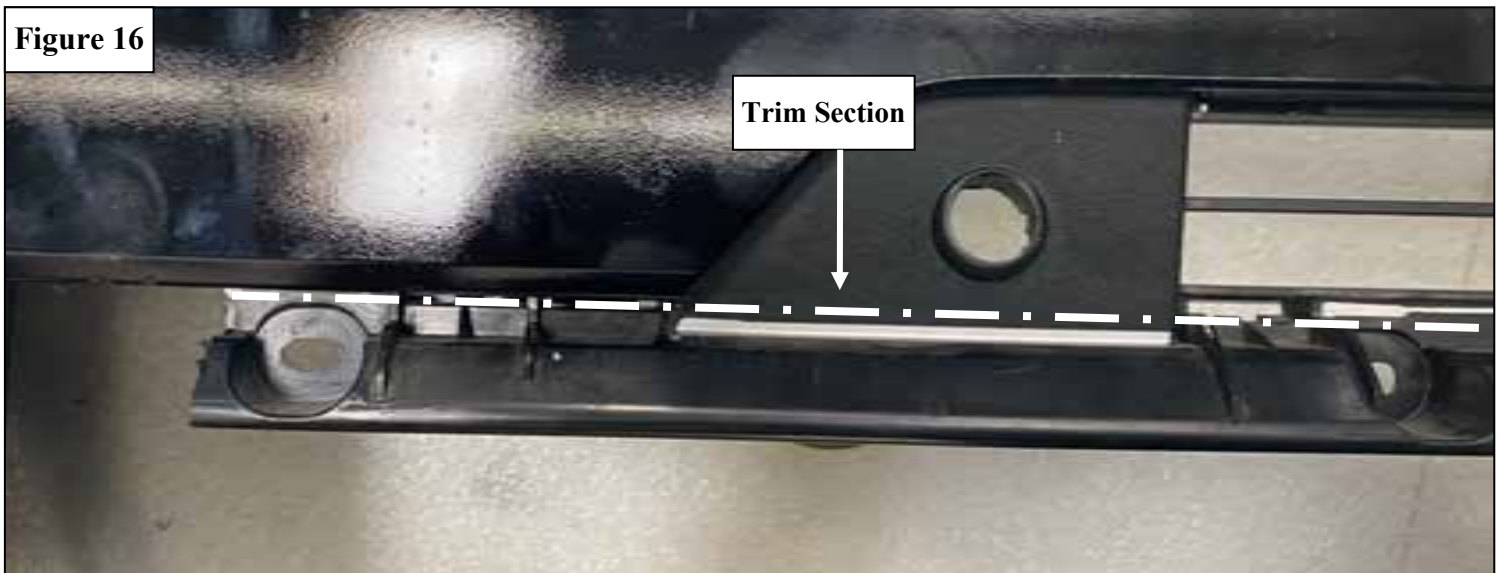

Figure 17

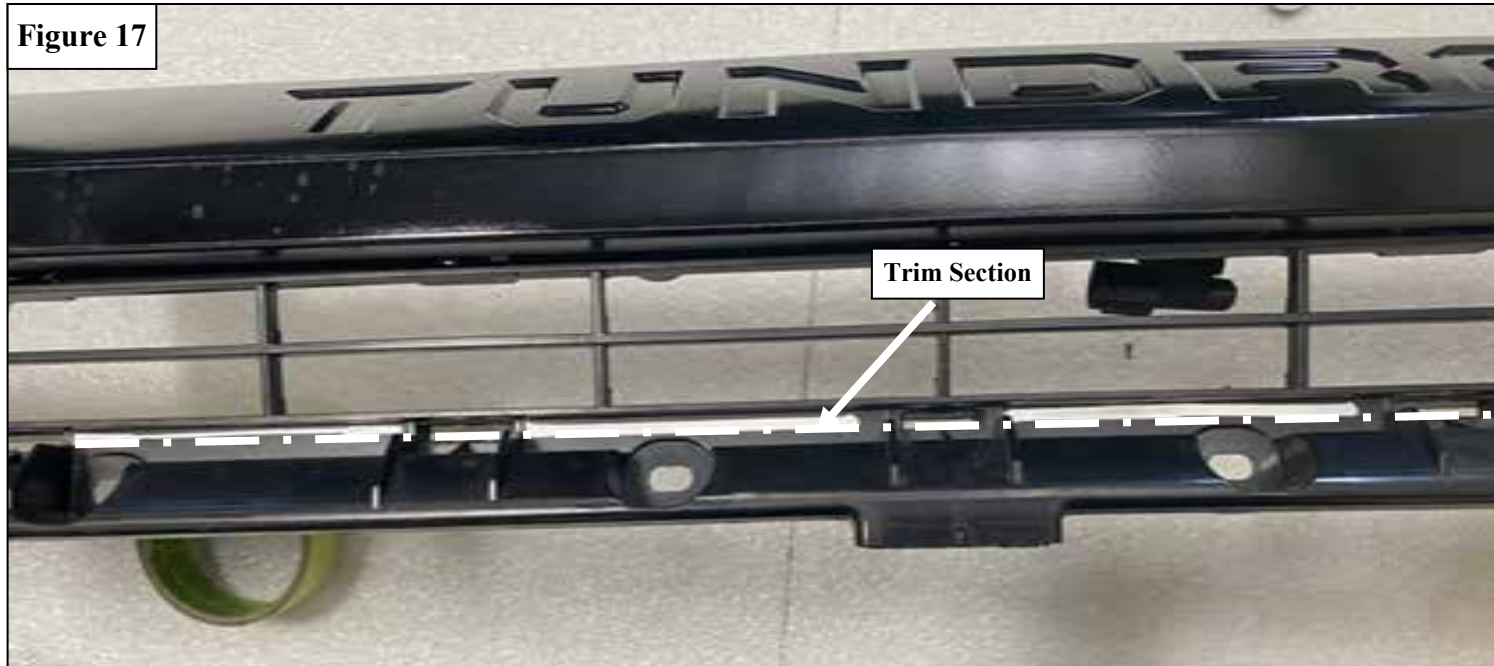
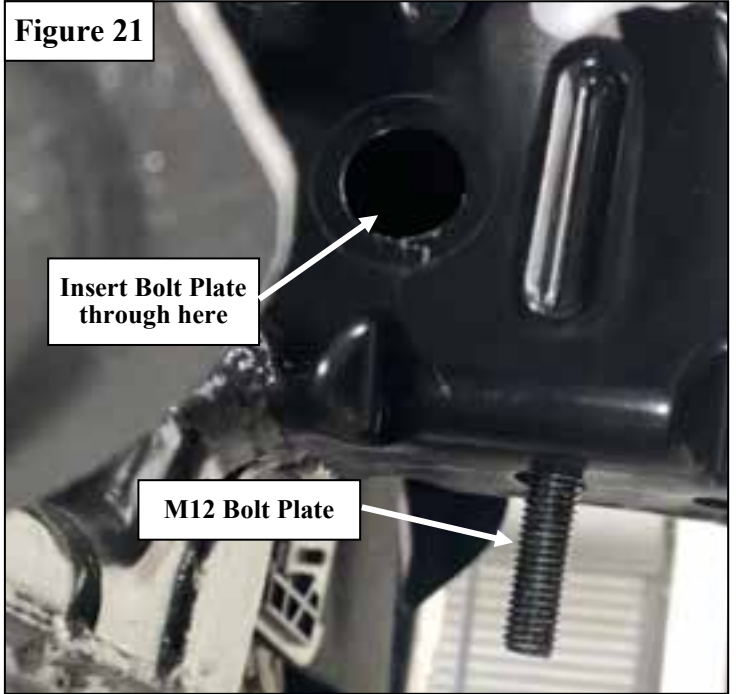

Figure 18



Pro-Series Install

NOTE: *Figure 19* is shown to demonstrate where to apply the Edge Trim (**Item 10**) if the Pro-Series Bumper does not have it already pre-installed.
19. Remove the aluminum crash bar from the frame of the vehicle and the factory skid plate
20. Slide the M12 Bolt Plate (**Item 11**) through the frame. See **Figure 20 & 21** for reference.



21. Locate the Driver Bracket (**Item 3**) and using the M12 hardware (**Items 19, 20, & 22**) provided loosely attach it to the frame of the vehicle. See **Figure 22** for reference.
22. Locate the Support Driver Bracket (**Item 7**) and using the M12 hardware (**Item 19, 20, & 22**) provided loosely attach it to the frame of the vehicle and to the Driver Bracket (**Item 3**). See **Figure 23** for reference.
23. Locate the Frame Support Driver Bracket (**Item 5**) and using the M12 hardware (**Item 18-22**) provided loosely attach it to the frame of the vehicle and to the Driver Bracket (**Item 3**). Line up the Frame Support Driver Bracket with the hole and the M12 Bolt Plate (**Item 11**) that was placed previously. See **Figure 24 & 25** for reference.
24. Repeat **Step 22-24** on the passenger side of the vehicle.

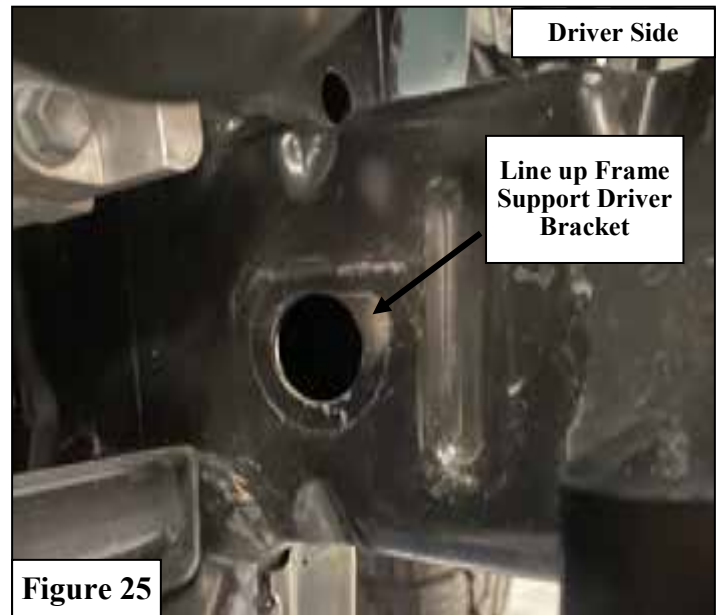
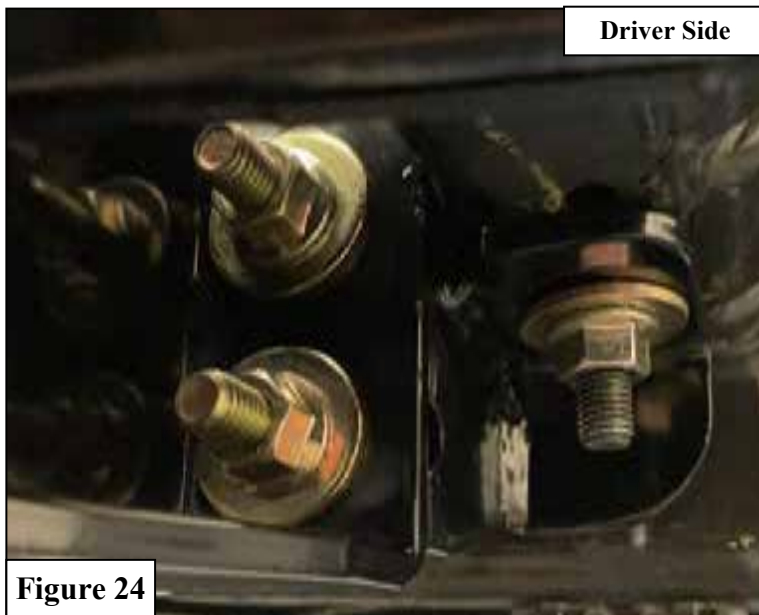
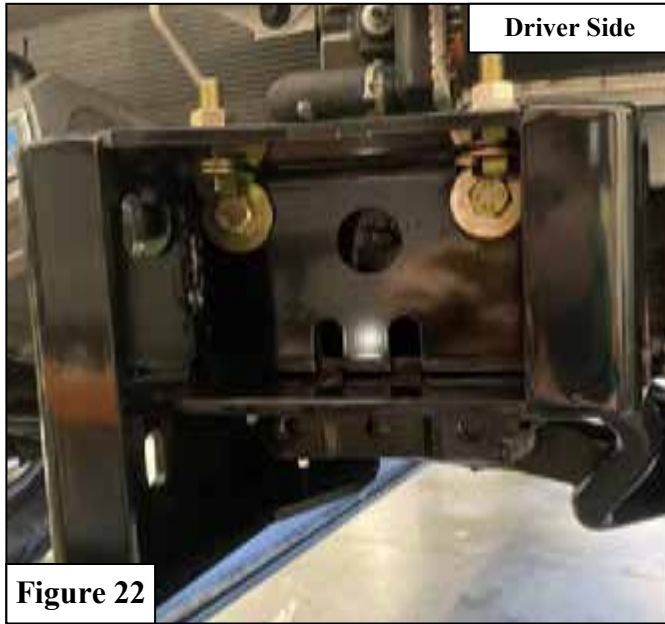

25. Insert the Pro-Series Front Bumper (**Item 1**) and using the M12 hardware (**Items 19, 20, & 22**) provided loosely attach it to the Driver Bracket (**Item 3**) and Passenger Bracket (**Item 4**). See **Figure 25 & 26** for reference.

Figure 25



Figure 26



26. Locate the Skid Plate Bracket (**Item 9**) and using the M12 hardware begin to loosely attach it to the Pro-Series Front Bumper (**Item 1**). See **Figure 27 & 28** for reference.

Figure 27

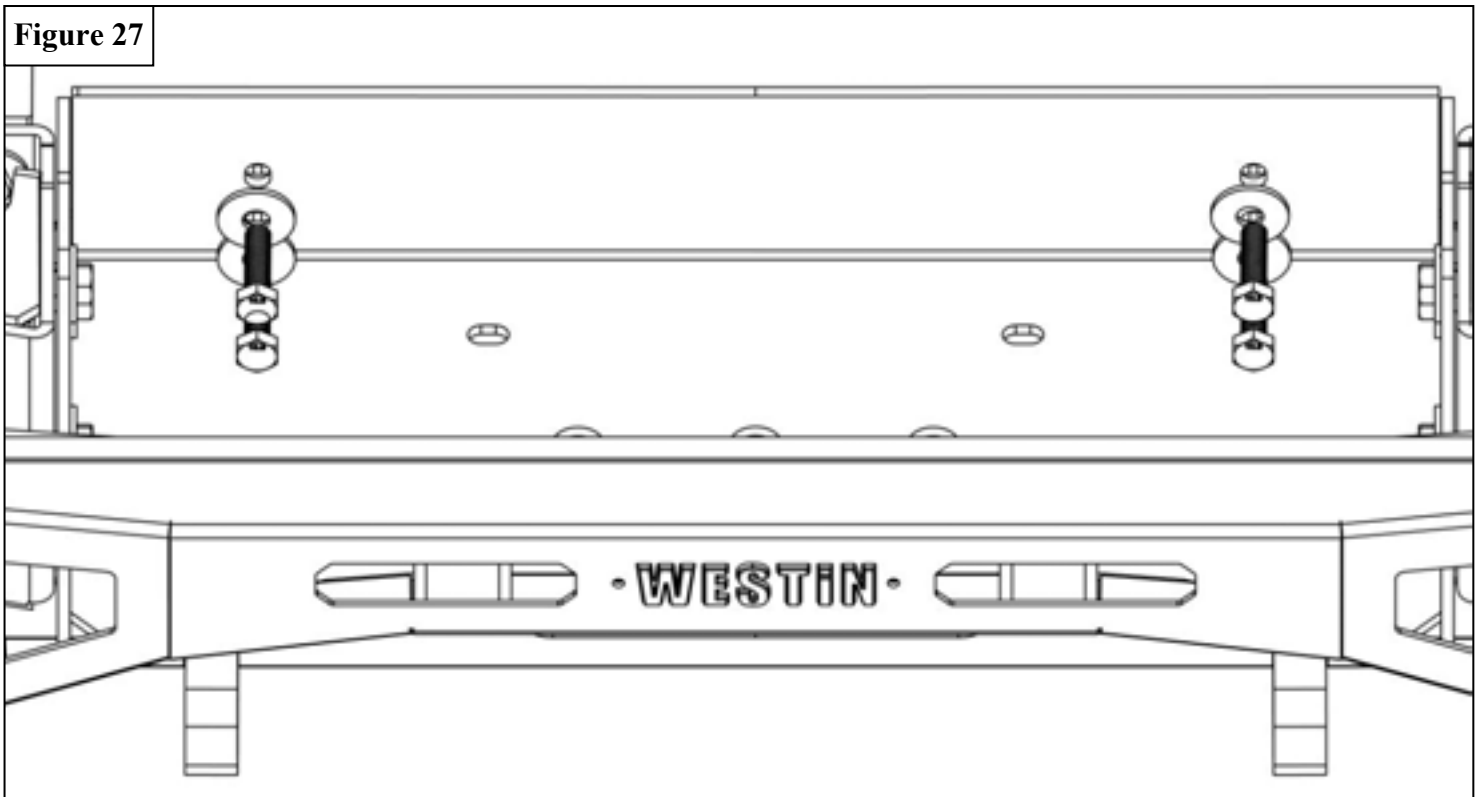
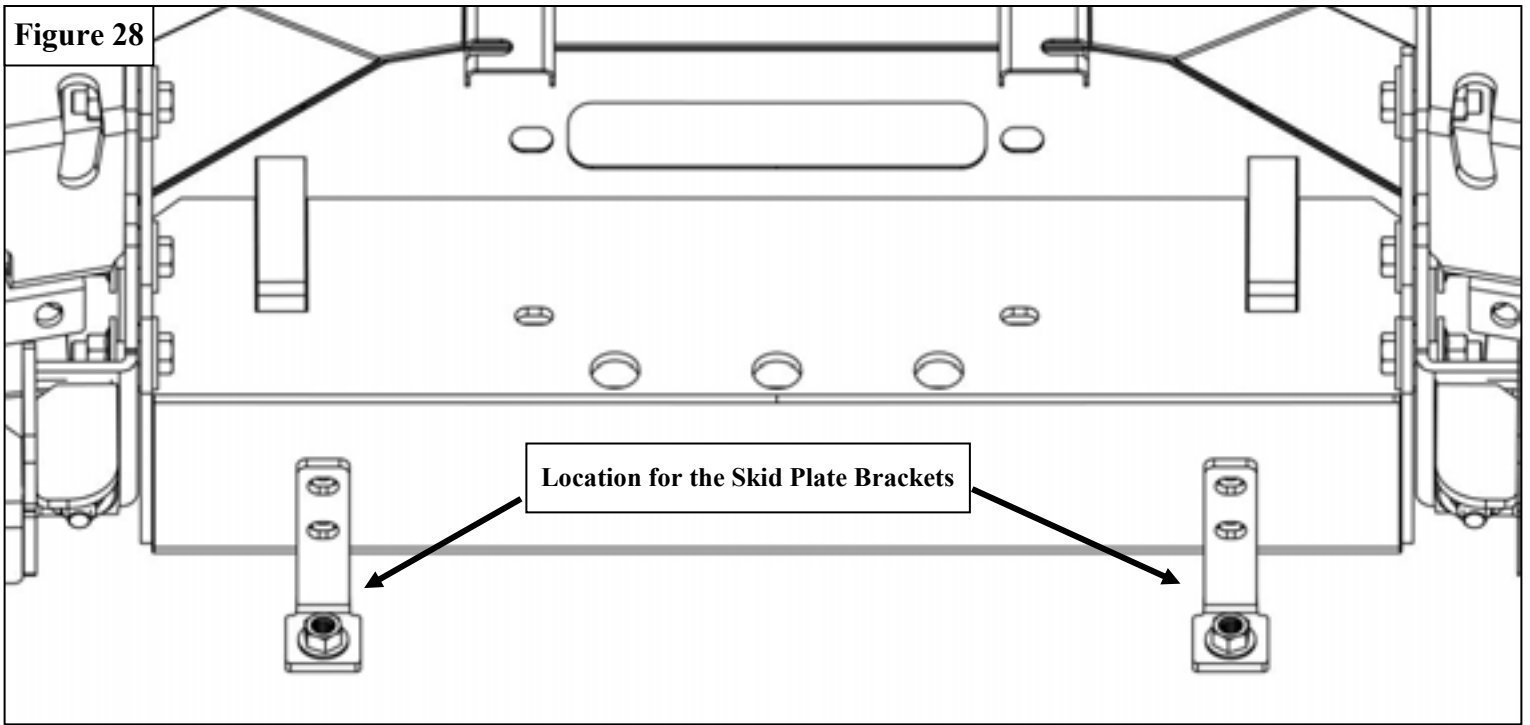
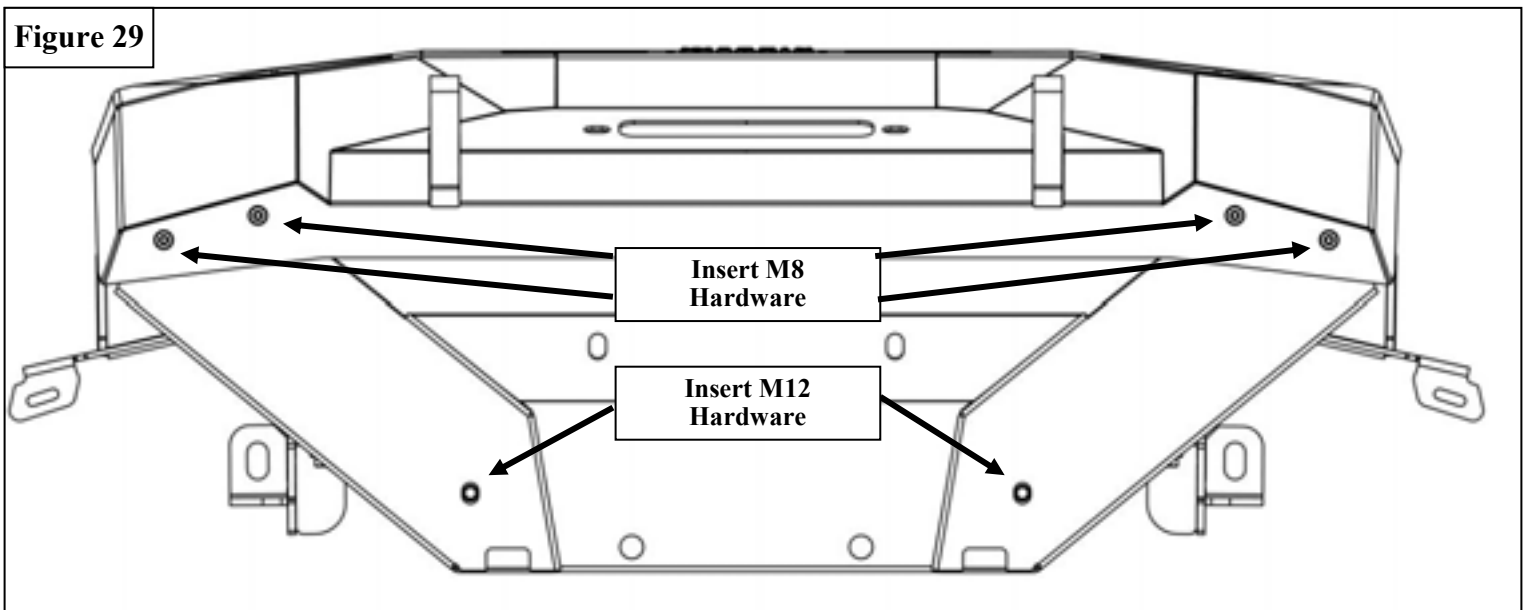

Figure 28



27. Use the provided M8 hardware (**Item 15-17**) and M12 hardware (**Item 19-22**) loosely attach the Skid Plate (**Item 2**) to the vehicle and to the Pro-Series Front Bumper (**Item 1**). See **Figure 29** for reference.
28. Align and adjust the Pro-Series Front Bumper and Mounting Brackets as necessary. Fully tighten and torque all hardware as specified: M6 hardware to 5-7 ft-lbs., M8 hardware to 15-18 ft-lbs., and M12 hardware to 55-60 ft-lbs.
29. Reinstall the front bumper of the vehicle. **NOTE:** Make sure to add all plastic clips and connect any wires to be able to prevent any errors from happening.

Figure 29



INSTALLATION COMPLETE



Pre-Production prototype shown. Actual product is compatible with a set of Westin 09-12232-PR lights.

CARE INSTRUCTIONS

- REGULAR WAXING IS RECOMMENDED. DO NOT USE ANY TYPE OF POLISH OR WAX THAT MAY CONTAIN ABRASIVES.
- STAINLESS STEEL PRODUCTS CAN BE CLEANED WITH MILD SOAP AND WATER. STAINLESS STEEL POLISH SHOULD BE USED TO POLISH SMALL SCRATCHES.
- GLOSS BLACK FINISHES SHOULD BE CLEANED WITH MILD SOAP AND WATER.

WESTIN Westin Automotive Products, Inc.
320 W. Covina Blvd
San Dimas, Ca. 91773

**Thank you for choosing Westin products
for additional installation assistance please call
Customer Service (800) 793-7846**

www.westinautomotive.com



WARNING



Failure to follow these instructions could lead to death, personal injury, and / or property damage.

Failure to follow these instructions could lead to death, personal injury, and / or property damage.

FASTENERS:

All Westin supplied fasteners must be utilized and installed in accordance with the installation instructions and apply torque to the specifications as defined. **DOUBLE CHECK ALL FASTENERS BEFORE INITIAL USE, AND PERIODICALLY IN THE FUTURE TO ENSURE PROPER FUNCTION AND SAFETY.**

DRILLING:

Most Westin products do not require drilling for installation. If drilling is defined as required, use caution when drilling a vehicle. **FAILURE TO REVIEW AN AREA TO BE DRILLED MAY RESULT IN PERSONAL INJURY AND/OR INJURY TO OTHERS AS WELL AS VEHICLE DAMAGE.**

EYE PROTECTION:

ALWAYS WEAR SAFETY GLASSES OR GOGGLES DURING THE INSTALLATION PROCESS TO AVOID PERSONAL INJURY.

MAXIMUM TOWING/CARRYING CAPACITY: (if applicable)

The Westin Receiver Hitches will have a visible tow rating label affixed directly on the product. User should never exceed the vehicle manufacturers maximum tow and weight rating regardless of the capacity of the hitch. **FAILURE TO FOLLOW THESE GUIDELINES WILL VOID THE WESTIN WARRANTY AND MAY RESULT IN PERSONAL INJURY AND/OR INJURY TO OTHERS AS WELL AS VEHICLE DAMAGE.**

FOR CALIFORNIA RESIDENTS ONLY-PROP 65 WARNING:

Some products may contain chemicals such as DEHP, which can cause cancer, birth defects or other reproductive harm. For more info go to www.p65warnings.ca.gov



Westin Automotive Products, Inc.
320 W. Covina Blvd
San Dimas, Ca. 91773