

INSTALLATION INSTRUCTIONS

HDX Bandit Front Bumper

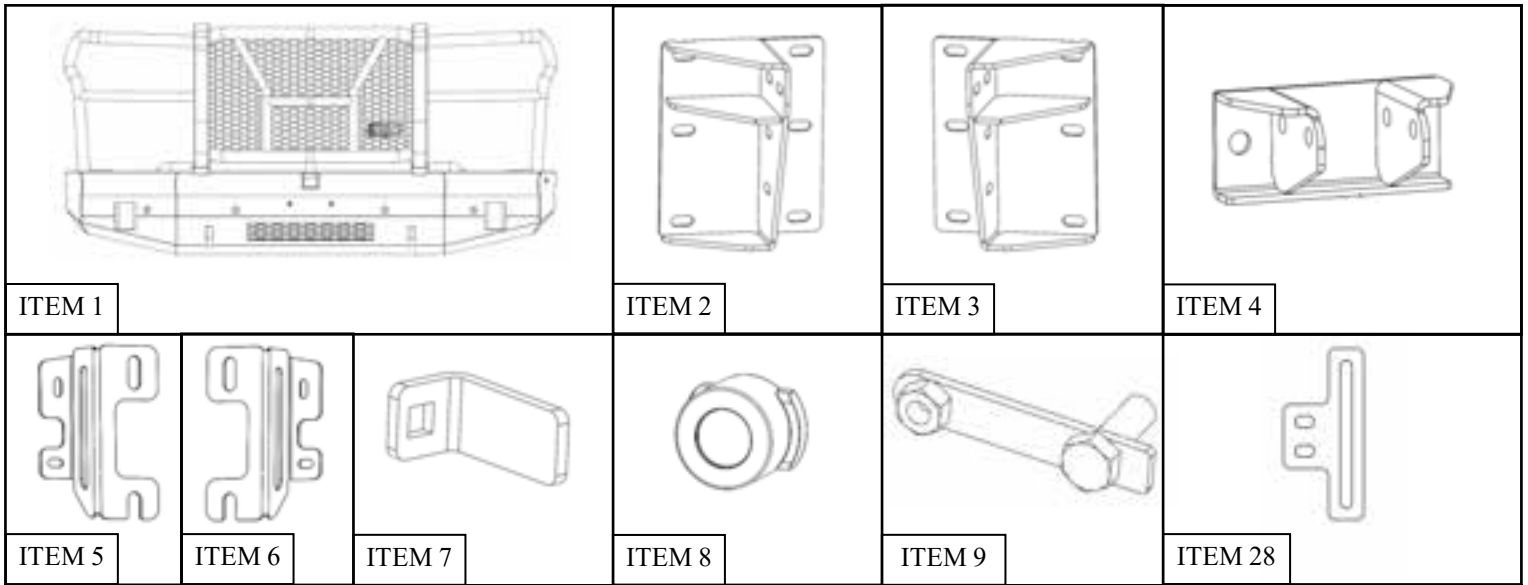


APPLICATION:
2024 Chevrolet Silverado 2500/3500
PART NUMBER:
58-31215

CONTENT

ITEM	QUANTITY	DESCRIPTION	TOOLS NEEDED
1	1	HDX BANDIT FRONT BUMPER	10MM SOCKET
2	1	DRIVER SIDE MOUNTING BRACKET	13MM SOCKET
3	1	PASSENGER SIDE MOUNTING BRACKET	13MM WRENCH
4	2	LOWER SUPPORT MOUNTING BRACKET	16MM SOCKET
5	1	DRIVER SIDE SHUTTER BRACKET	16MM WRENCH
6	1	PASSENGER SIDE SHUTTER BRACKET	18MM SOCKET
7	4	L-TAB SENSOR BRACKET	18MM WRENCH
8	4	PARKING SENSOR PLUG	TORX #15
9	4	NUT/BOLT PLATE	RATCHET
10	20	M12 HEX HEAD CAP SCREW (YELLOW ZINC)	TORQUE WRENCH
11	20	M12 SERRATED FLANGE NUT (YELLOW ZINC)	
12	4	M12 HEX NUT (YELLOW ZINC)	
13	24	M12 SPLIT LOCK WASHER (YELLOW ZINC)	
14	44	M12 FLAT WASHER (YELLOW ZINC)	
15	4	M10 HEX HEAD CAP SCREW (YELLOW ZINC)	
16	4	M10 SPLIT LOCK WASHER (YELLOW ZINC)	
17	4	M10 FLAT WASHER (YELLOW ZINC)	
18	6	M8 HEX HEAD CAP SCREW (YELLOW ZINC)	
19	6	M8 SPLIT LOCK WASHER (YELLOW ZINC)	
20	6	M8 FLAT WASHER (YELLOW ZINC)	
21	6	M8 SERRATED FLANGE NUT (YELLOW ZINC)	
22	6	M6 HEX HEAD CAP SCREW (BLACK ZINC)	
23	4	M6 ROUND HEAD SQUARE NECK CAP SCREW (BLACK ZINC)	
24	10	M6 HEX NUT (BLACK ZINC)	
25	10	M6 SPLIT LOCK WASHER (BLACK ZINC)	
26	16	M6 FLAT WASHER (BLACK ZINC)	
27	2	LICENSE PLATE GROMMET	
28	2	AFTERMARKET LED ADAPTER PLATE	

ANTI-SEIZE LUBRICANT MUST BE USED ON ALL STAINLESS STEEL FASTENERS TO PREVENT THREAD DAMAGE AND GALLING



PROCEDURE

- Remove contents from box, verify if all parts listed are present and free from damage.
Carefully read and understand all instructions before attempting installation.
Failure to identify damage before installation could lead to a rejection of any claim.
- Open the hood of the vehicle and remove the Torx screws from the hood release lever handle. See **Figure 1**.
- Remove the plastic top grille cover at the front by removing the plastic clips using a pry tool. See **Figure 2**.
- Remove the four bolts holding the grille in place. See **Figure 3**.
- Remove 2 bolts attaching wheel well cover to filler panel.



6. Pry fender trim away from the fender to access the filler panel clips. See **Figure 4**.
7. Pry filler panel off by removing any necessary bolts. See **Figure 5**.
8. Disconnect any electrical plugs, hose lines, and any bolts still attaching the grille to the vehicle. See **Figure 6**.
9. Remove the grille by prying any remaining clips attaching the grill to the vehicle.



Figure 4



Figure 5

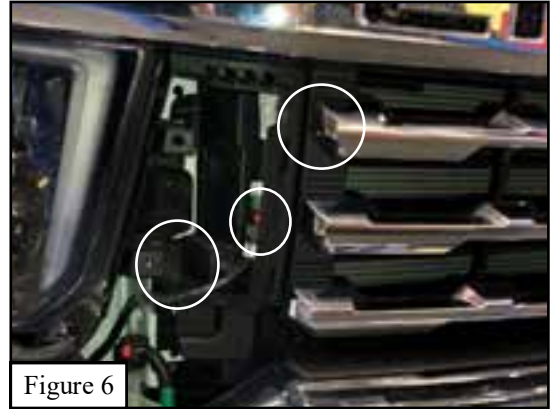


Figure 6

10. Remove the 4 upper bumper bolts attaching the bumper to the frame and remove the 2 bottom bolts attaching bumper arm to the frame. See **Figure 7 and 8** for reference.
11. Remove the front Bumper.

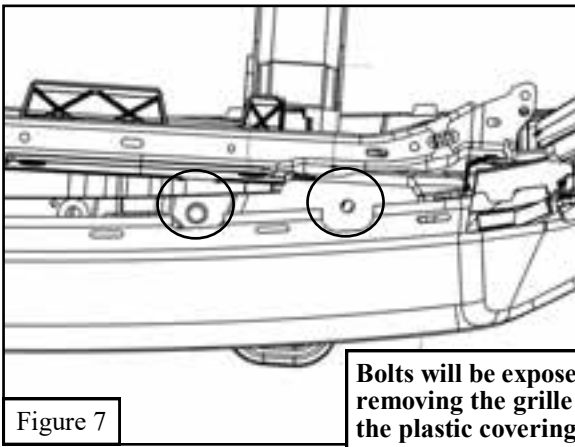


Figure 7

Bolts will be exposed after removing the grille and lifting the plastic covering them

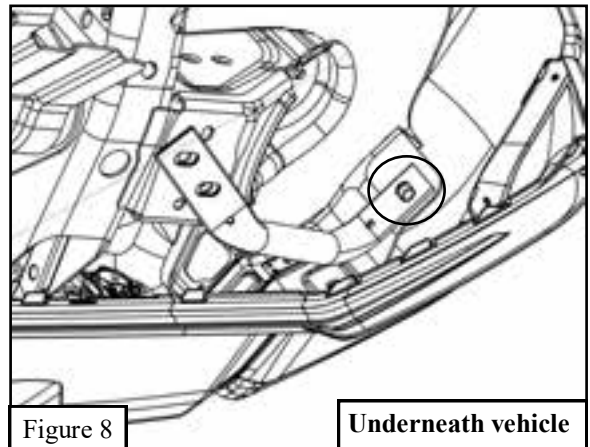


Figure 8

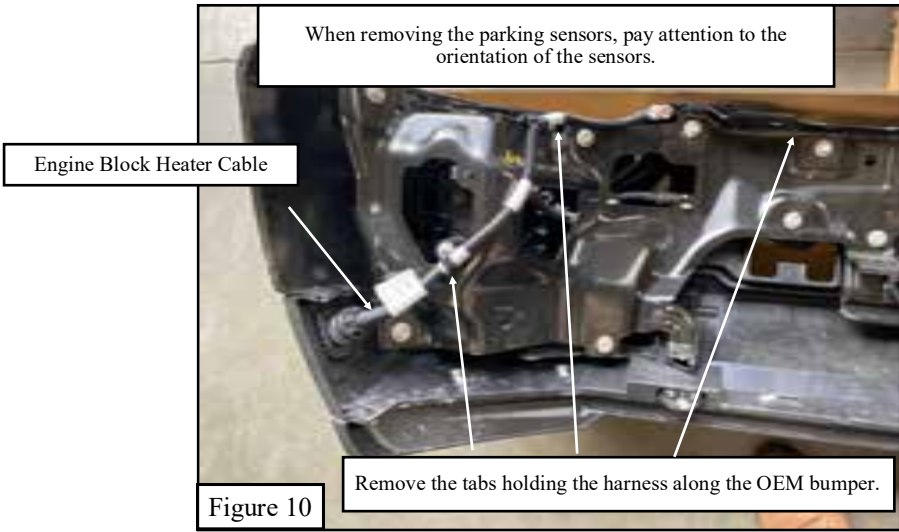
Underneath vehicle

12. Remove OE bumper brackets and Aerodynamic Active Shutters. See **Figure 9** for reference. *Note: Removal of Aerodynamic Active shutters may cause Check Engine Light to turn on. Be sure to complete **Step 22**.*

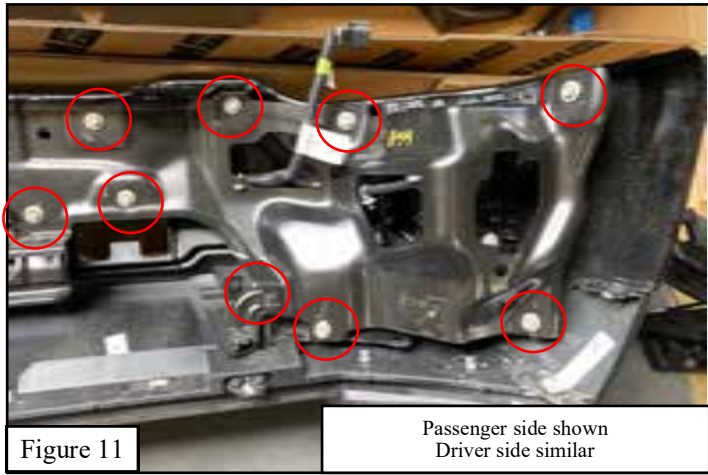


Figure 9

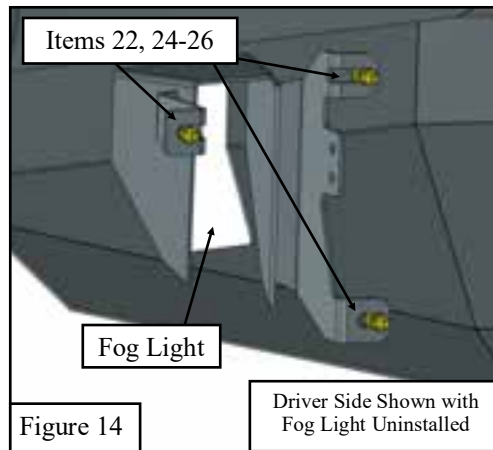
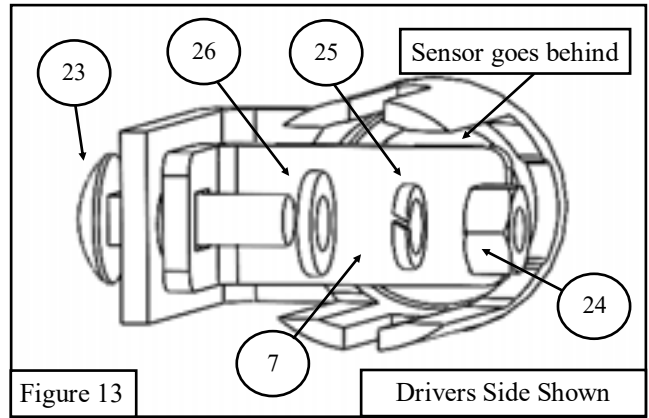
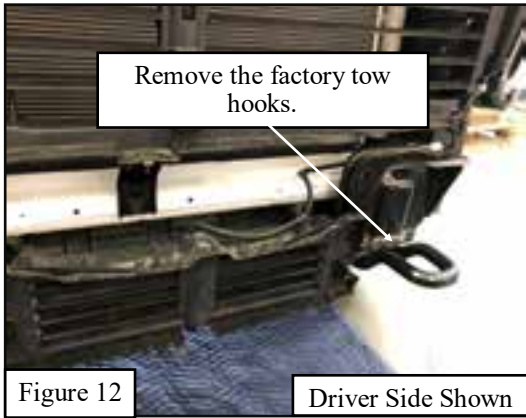
13. Once the bumper is removed, remove the sensors, sensor wiring harness. Carefully remove the sensors and make sure to pay attention to the sensor orientation since they must be reinstalled in the same orientation. If equipped, remove the engine block heater cable. See **Figure 10**.



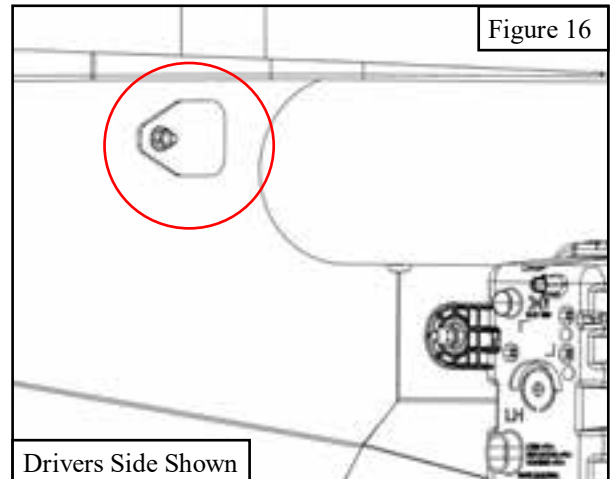
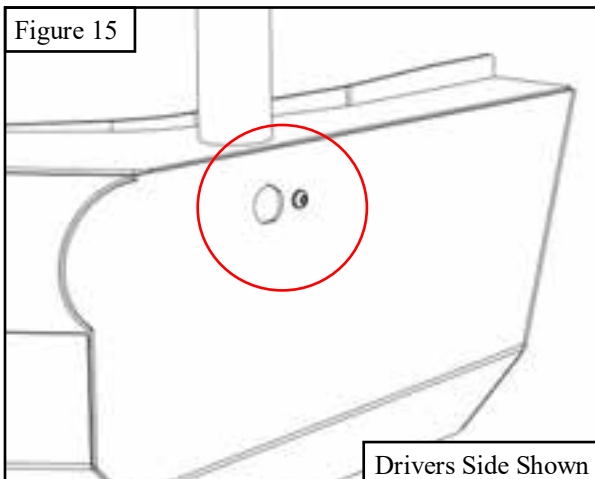
14. Remove the OEM fog lights. For each fog light, remove the (9) bolts securing the backing plate to the bumper with a 13mm socket. Additionally, remove the M6 bolts using a 10mm socket. This will allow the backing plate to be removed, gaining access to remove the fog light housing. Finally, use a 10mm socket to remove the fog light from the bumper, see **Figure 11**.



15. Remove the factory tow hooks. See **Figure 12** for reference.
16. Using the L-Tab sensor brackets and the provided M6 hardware (**items 7, 23-26**), install the parking sensors in the same orientation that they were removed from the OEM bumper. See **Figure 13** for reference.
17. Using the provided M6 hardware (**items 22, 24-26**), install the OEM fog lights in the Bandit bumper. See **Figures 14**. Refer to **Step 20** for installing aftermarket lights.
18. Secure the wiring harness inside the Bandit bumper with zip ties.



19. If equipped, install the engine block heater socket into the designated slot on the bumper shown below. Remove the bolt securing the cover plate and secure the plug in the hole. See **Figure 15 and 16** for reference.



20. To install aftermarket lights, attach the aftermarket light adapter plate (**Part 28**) using M6 bolt hardware. See **Figure 17**. Once installed, an aftermarket light may be mounted to the adapter plate. See **Figure 18**.

Figure 17

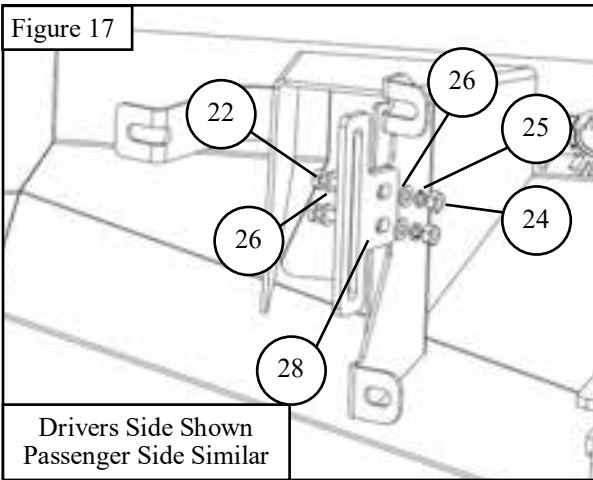
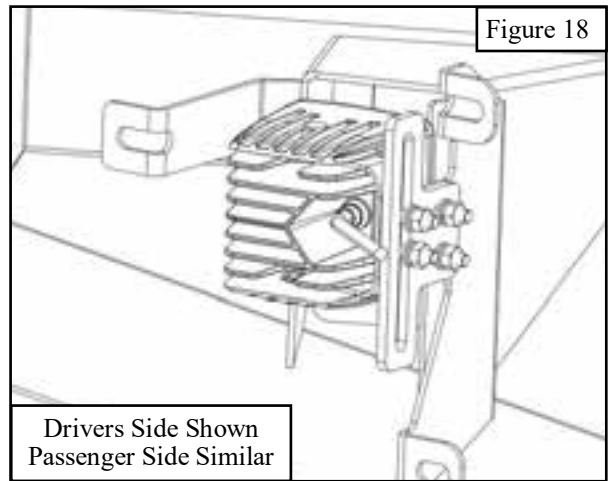
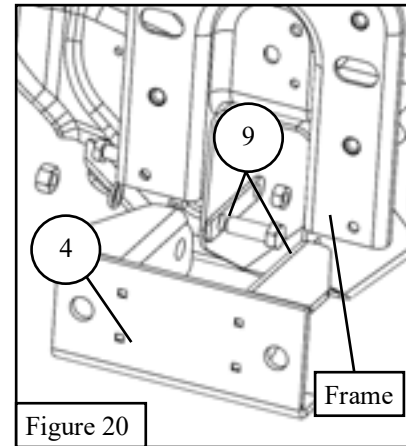
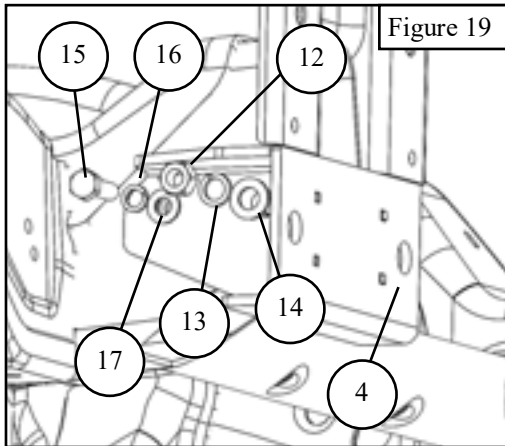


Figure 18



21. Using supplied M12/M10 bolt/nut plate (**item 9**) and M10/M12 hardware (**items 12-17**), slide in and loosely assemble the (2) lower mounting brackets to the frame. The bolt/nut plate will be installed inside the frame. See **Figures 19 & 20** for reference.

Figure 19



22. Using the supplied M12 hardware (**items 10-11, 13-14**), loosely install the driver and passenger mounting brackets to the frame. See **Figures 21-23**. **Note:** Be sure to reuse the OEM bolts where the welded nuts are located on the frame.

23. Using the supplied M12 hardware (**items 10-11, 13-14**), install the shutter brackets to the mounting brackets.

24. Install the shutters onto the shutter brackets.

Figure 21

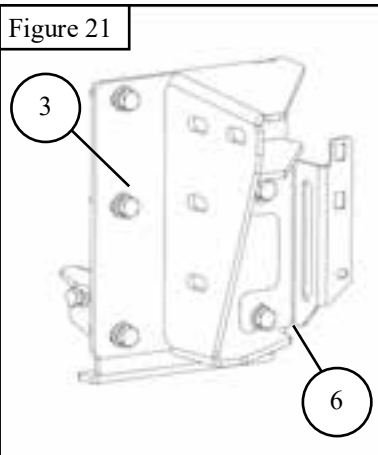


Figure 22

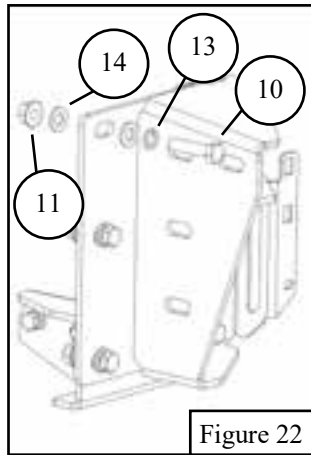
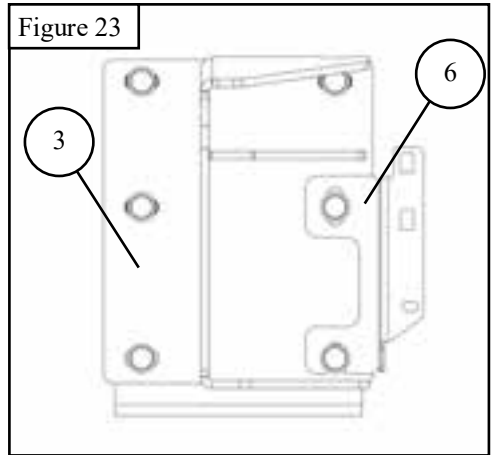
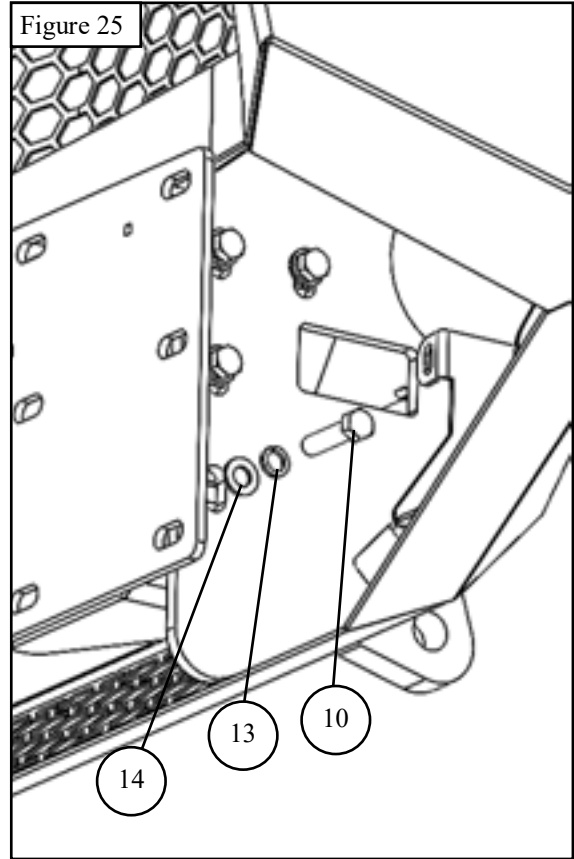
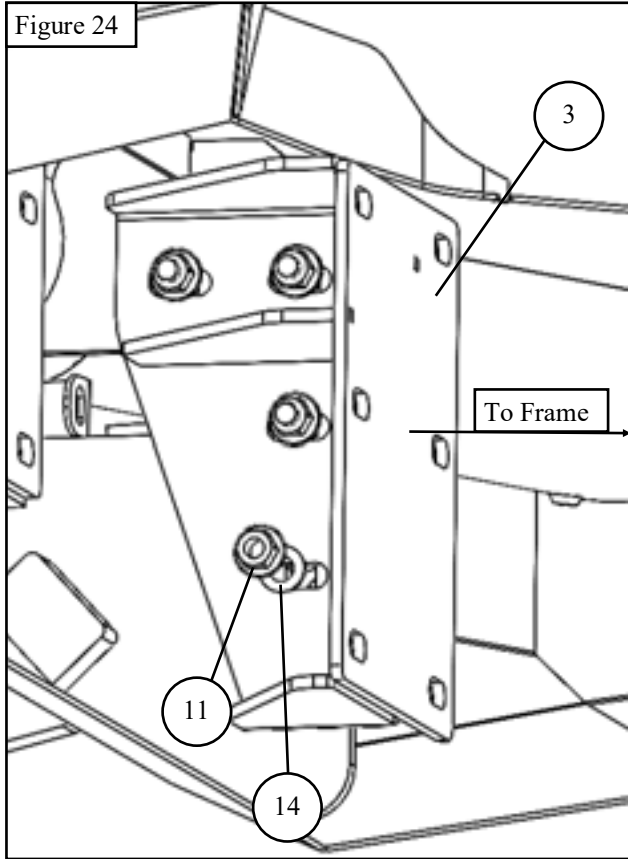


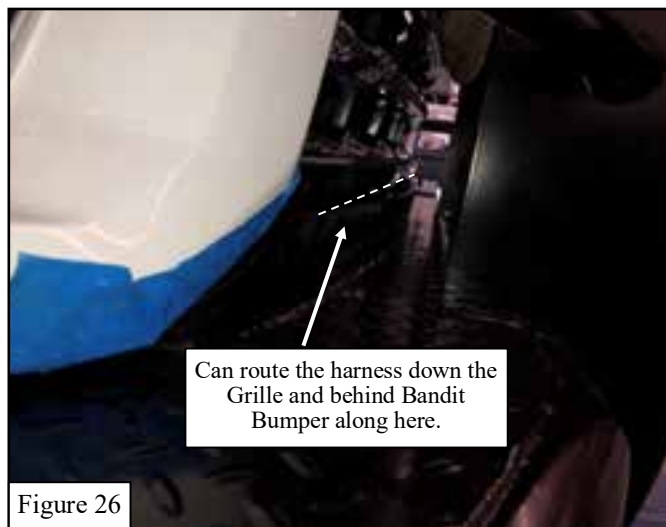
Figure 23



25. Caution: The bumper is heavy and difficult to handle. It is recommended to have someone assist you during installation.
 Using a floor jack, raise the bumper in to place on the mounting brackets. Using supplied M12 hardware (items 10-11, 13-14), loosely assemble the bumper to the brackets. See **Figures 24 & 25** for reference



26. Reconnect any wiring harnesses or hoses to their respective locations. Se Figure 26.



27. Adjust the bumper as needed. Torque as specified: M6 to 5-7 ft-lbs, M8 to 14-16 ft-lbs M10 to 35-40 ft-lbs., M12 to 55-60 ft-lbs.

INSTALLATION COMPLETE



CARE INSTRUCTIONS

- REGULAR WAXING IS RECOMMENDED. DO NOT USE ANY TYPE OF POLISH OR WAX THAT MAY CONTAIN ABRASIVES.
- STAINLESS STEEL PRODUCTS CAN BE CLEANED WITH MILD SOAP AND WATER. STAINLESS STEEL POLISH SHOULD BE USED TO POLISH SMALL SCRATCHES.
- GLOSS BLACK FINISHES SHOULD BE CLEANED WITH MILD SOAP AND WATER.

WESTIN

Westin Automotive Products, Inc.
320 W. Covina Blvd
San Dimas, Ca. 91773

Thank you for choosing Westin products
for additional installation assistance please call
Customer Service (800) 793-7846
www.westinautomotive.com



WARNING



Failure to follow these instructions could lead to death, personal injury, and / or property damage.

Failure to follow these instructions could lead to death, personal injury, and / or property damage.

FASTENERS:

All Westin supplied fasteners must be utilized and installed in accordance with the installation instructions and apply torque to the specifications as defined. **DOUBLE CHECK ALL FASTENERS BEFORE INITIAL USE, AND PERIODICALLY IN THE FUTURE TO ENSURE PROPER FUNCTION AND SAFETY.**

DRILLING:

Most Westin products do not require drilling for installation. If drilling is defined as required, use caution when drilling a vehicle. **FAILURE TO REVIEW AN AREA TO BE DRILLED MAY RESULT IN PERSONAL INJURY AND/OR INJURY TO OTHERS AS WELL AS VEHICLE DAMAGE.**

EYE PROTECTION:

ALWAYS WEAR SAFETY GLASSES OR GOGGLES DURING THE INSTALLATION PROCESS TO AVOID PERSONAL INJURY.

MAXIMUM TOWING/CARRYING CAPACITY: (if applicable)

The Westin Receiver Hitches will have a visible tow rating label affixed directly on the product. User should never exceed the vehicle manufacturers maximum tow and weight rating regardless of the capacity of the hitch. **FAILURE TO FOLLOW THESE GUIDELINES WILL VOID THE WESTIN WARRANTY AND MAY RESULT IN PERSONAL INJURY AND/OR INJURY TO OTHERS AS WELL AS VEHICLE DAMAGE.**

FOR CALIFORNIA RESIDENTS ONLY-PROP 65 WARNING:

Some products may contain chemicals such as DEHP, which can cause cancer, birth defects or other reproductive harm. For more info go to www.p65warnings.ca.gov



Westin Automotive Products, Inc.
320 W. Covina Blvd
San Dimas, Ca. 91773