

INSTALLATION INSTRUCTIONS

MANUAL TONNEAU COVER



APPLICATION: 2024-2025 TOYOTA TACOMA 5' BED

PART NUMBER: 19-62785

CONTENT			
ITEM	QUANTITY	DESCRIPTION	TOOLS NEEDED
1	1	TONNEAU COVER CANISTER ASSEMBLY	PHILLIPS SCREWDRIVER
2	1	CANISTER COVER PLATE	FLAT SCREWDRIVER
3	1	DRIVER SIDE RAIL	RATCHET
4	1	PASSENGER SIDE RAIL	10MM SOCKET
5	1	ALIGNMENT BAR	10MM WRENCH
6	4	MOUNTING BRACKET	13MM SOCKET
7	1	REAR DRIVER MOUNTING BRACKET	13MM WRENCH
8	1	REAR PASSENGER MOUNTING BRACKET	SCISSORS
9	8	THREADED MOUNT BLOCK	
10	2	FRONT DRAIN TUBE	
11	2	REAR DRAIN TUBE	
12	2	FRONT DRAIN TUBE ADAPTER	
13	2	RUBBER RING	
14	2	FRONT TUBE CLAMP	
15	2	REAR TUBE CLAMP	
16	3	BED RAIL TOP FOAM SEAL	
17	1	BED FRONT GAP FOAM SEAL	
18	1	ADHESION PROMOTER	
19	1	19MM HOLE SAW	
20	6	M6 T-CHANNEL NUT	
21	16	M6 x 16MM TORX COMBO BOLT	
22	2	M6 x 20MM TORX COMBO BOLT	
23	2	M6 x 35MM TORX COMBO BOLT	
24	8	M8 TORX BOLT	
25	8	M8 LOCK WASHER	
26	8	M8 FLAT WASHER	
27	6	PLASTIC RING	
28	6	M5 COUNTERSUNK SCREW	

ANTI-SEIZE LUBRICANT MUST BE USED ON ALL STAINLESS STEEL FASTENERS TO PREVENT THREAD DAMAGE AND GALLING

Item 1

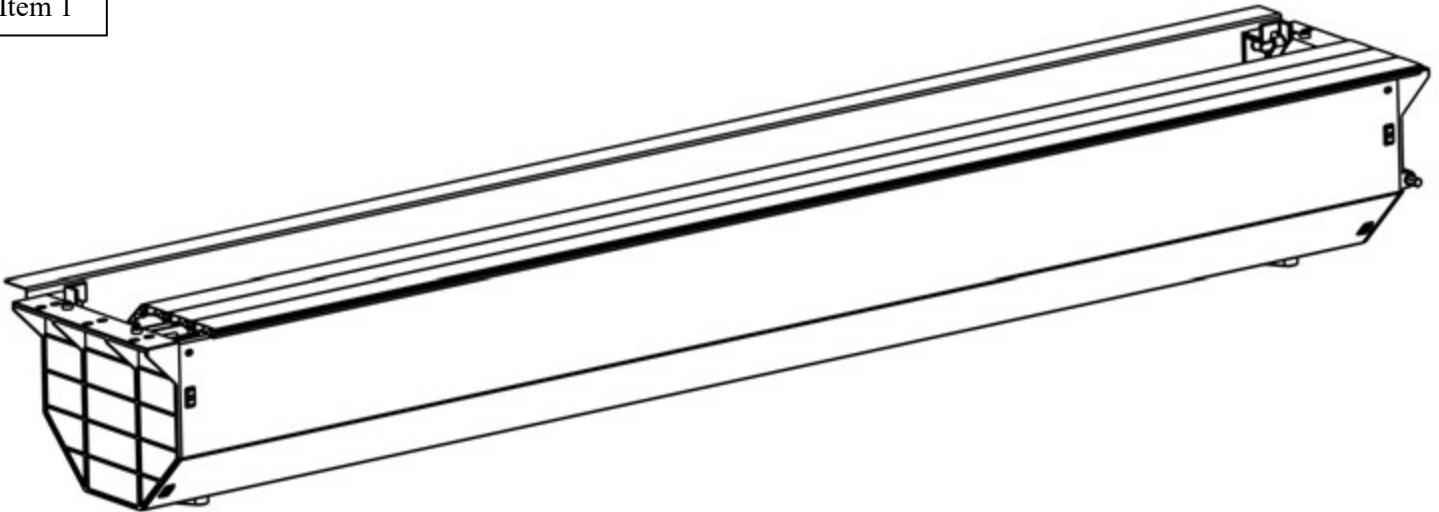

Item 2

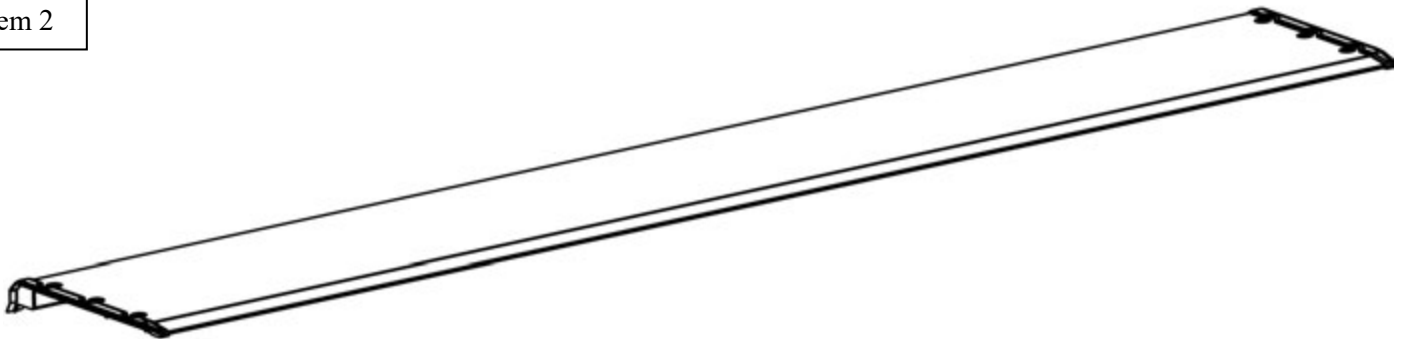

Item 3



Passenger Side Opposite

Item 5



Item 6

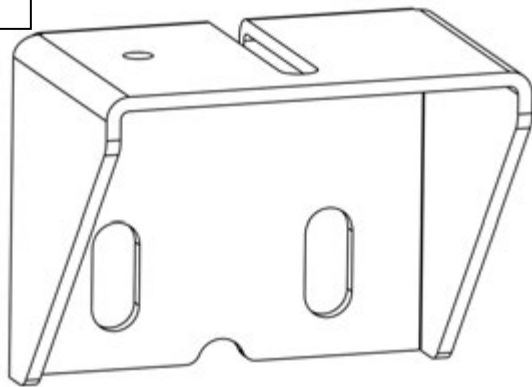

Item 7

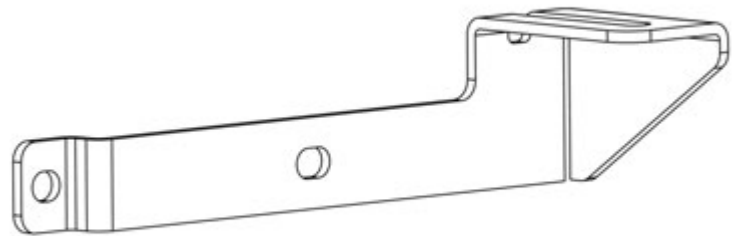

Passenger Side Opposite



Westin Automotive Products, Inc.
320 W. Covina Blvd
San Dimas, Ca. 91773

Thank you for choosing Westin products
for additional installation assistance please call
Customer Service (800) 793-7846

www.westinautomotive.com

DATE: 01/13/2026

Item 9

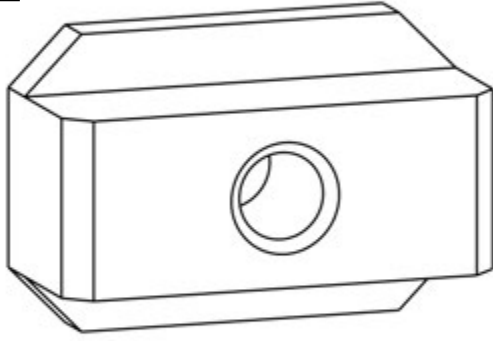

Item 10

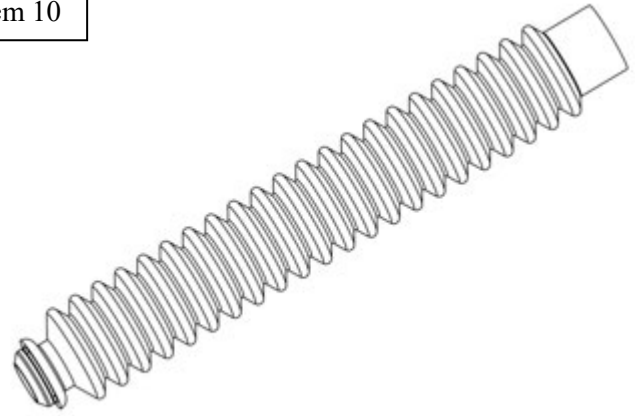

Item 11

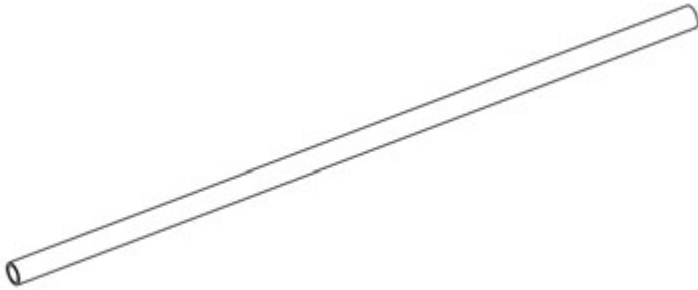

Item 12

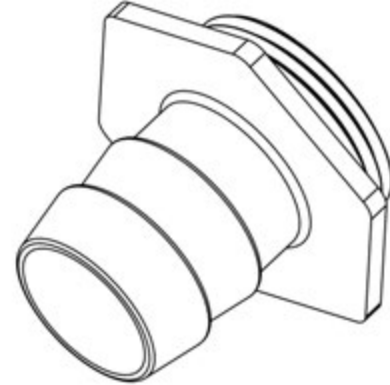

Item 13

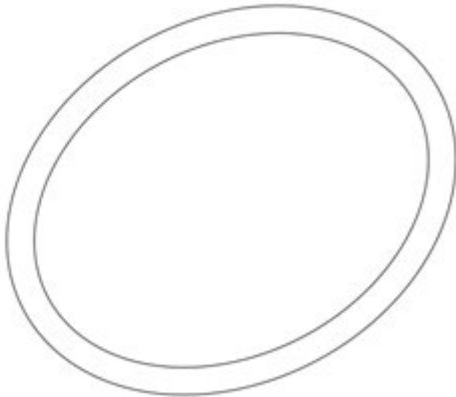

Item 14

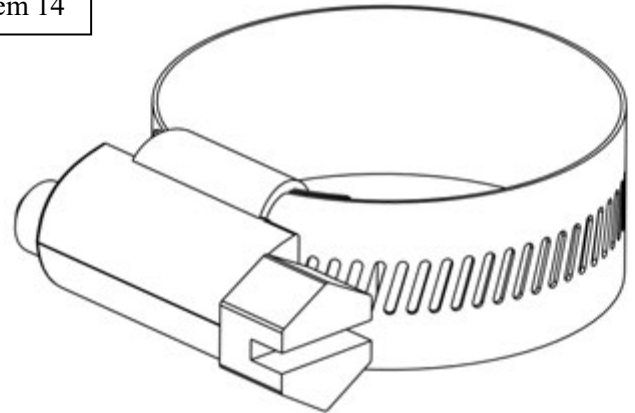

Item 15

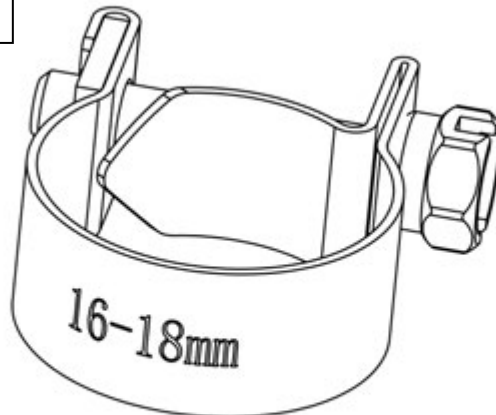

Westin Automotive Products, Inc.
320 W. Covina Blvd
San Dimas, Ca. 91773

Thank you for choosing Westin products
for additional installation assistance please call
Customer Service (800) 793-7846
www.westinautomotive.com

Item 16



Soft Foam Seal

Item 17



Hard Foam Seal

Item 18



Item 19



PROCEDURE

1. Remove contents from box, verify that all parts listed are present and free from damage. Carefully read and understand all instructions before attempting installation. **Failure to identify damage before installation could lead to a rejection of any claim.**
2. Remove the plastic caps at the end of the side-mounted utility track and slide in 4 M8 Threaded Mount Blocks (Item 9). Repeat this step for the opposite side utility track. See **Figures 1 & 2.**

Figure 1

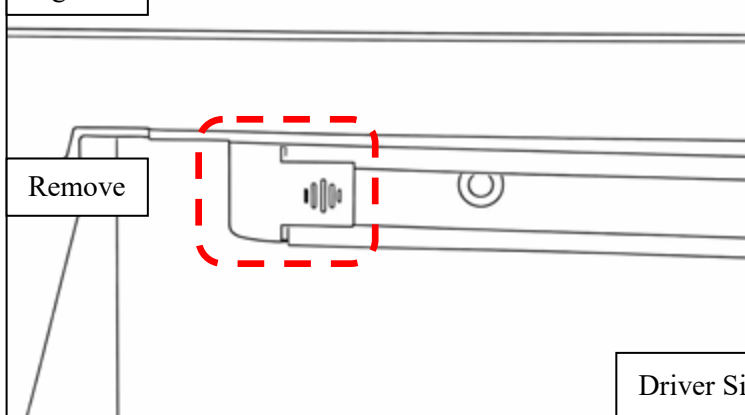

Remove

Figure 2

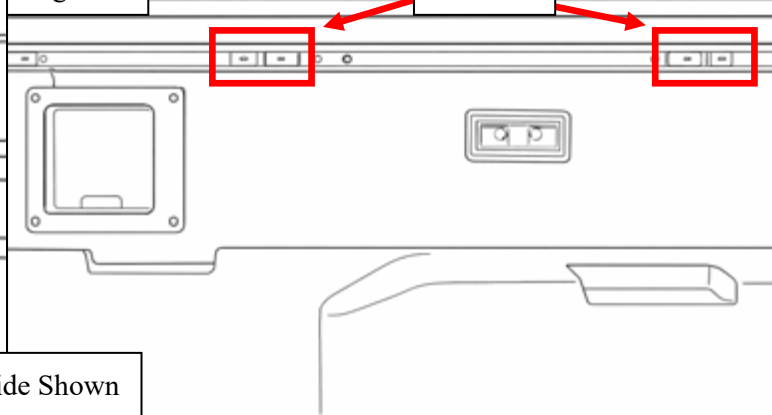

Item 9

Driver Side Shown



Westin Automotive Products, Inc.
320 W. Covina Blvd
San Dimas, Ca. 91773

Thank you for choosing Westin products
for additional installation assistance please call
Customer Service (800) 793-7846

www.westinautomotive.com

DATE: 01/13/2026

3. Measure approximately 4 1/4" (108 mm) from the side of the bed, and 2" (50mm) up from the base of the bed. Repeat this for both sides of the bed. Use the included 19MM Hole Saw (**Item 19**) to cut the front drain tube holes. The holes will be drilled into the raised vertical ribs at the front of the bed. See **Figure 3**.
4. The holes for the rear drain tubes need to be drilled approximately 9 1/4" (235 mm) from the base of the bed. There are three indentations in the bed side, use the upper, innermost indentation as the starting point for the drain tube hole. Use the included 19MM Hole Saw (**Item 19**) to drill one hole on each side of the bed. See **Figure 4**.

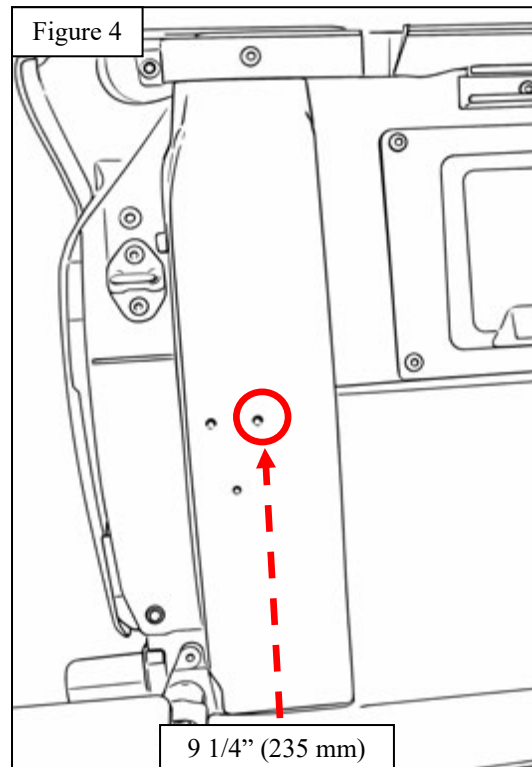
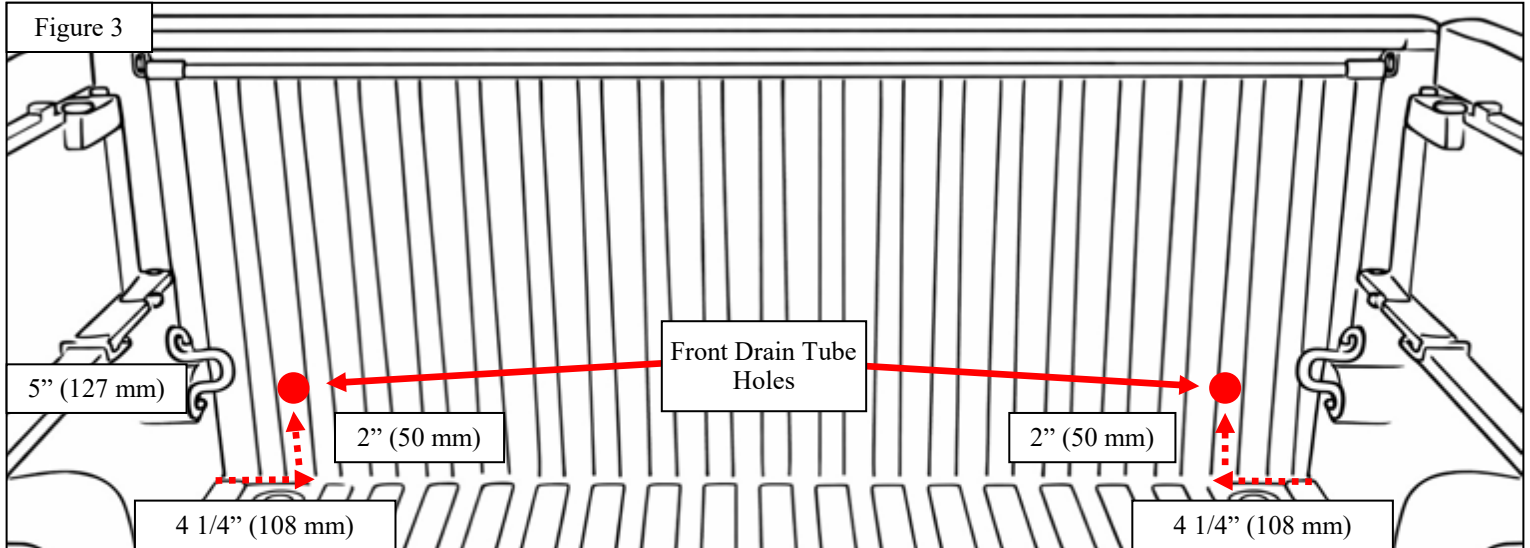

5. Clean the top of the plastic bed caps and the top of the front bed wall of dirt and debris. Install Bed Front Gap Foam Seal (hard foam seal, **Item 17**) across the top of the front bed wall. See **Figures 5-9**.
6. Install the Bed Rail Top Foam Seal (soft foam seal, **Item 16**) across the top of the front bed wall (on top of the hard foam seal) and the plastic bed caps. A small amount of sealant may be applied at the corners of the front bulkhead to improve water resistance. See **Figures 10 & 11**.

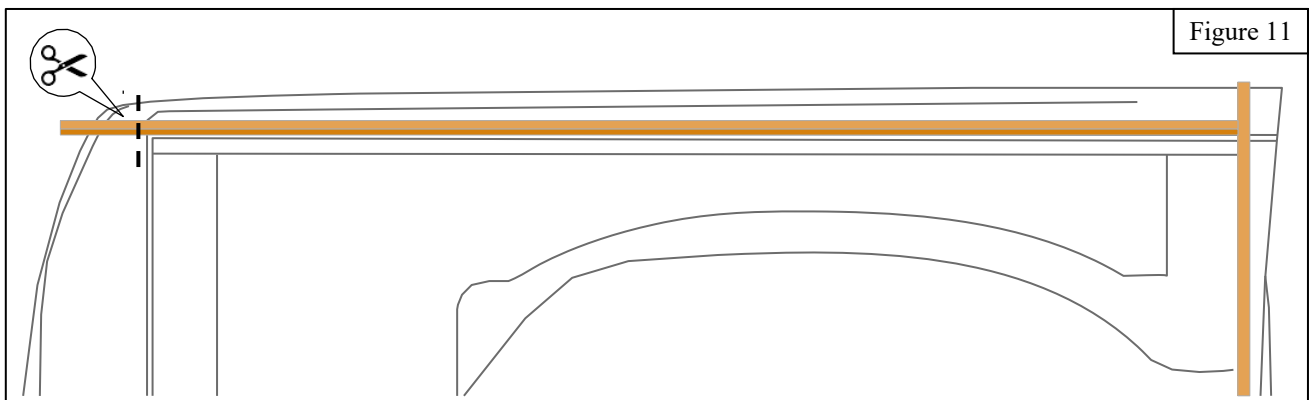
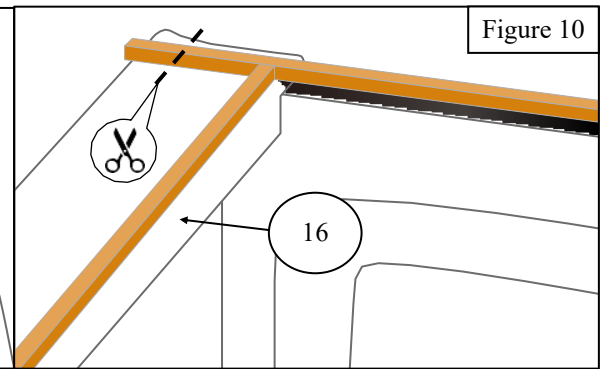
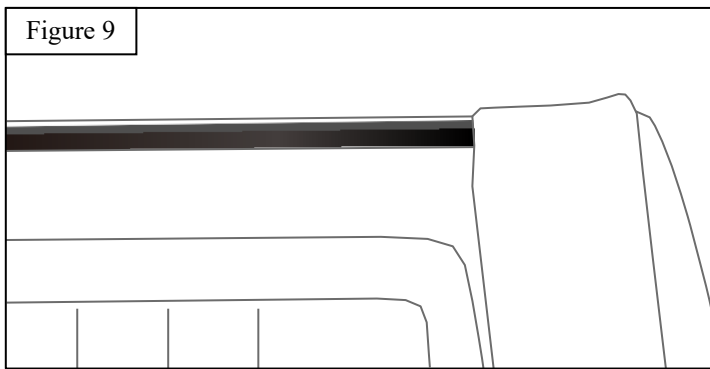
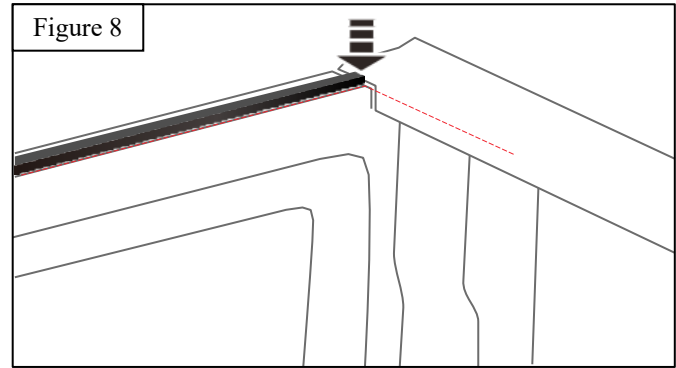
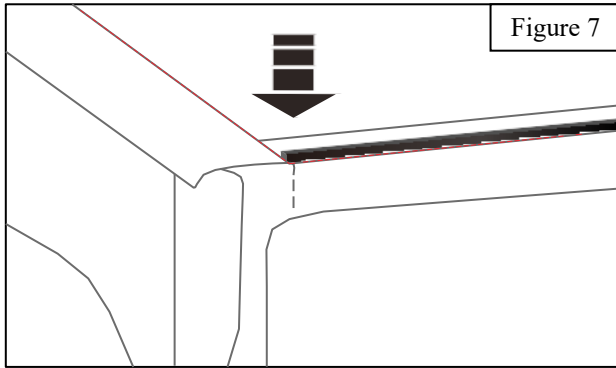
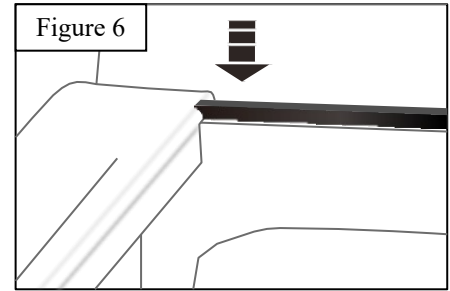
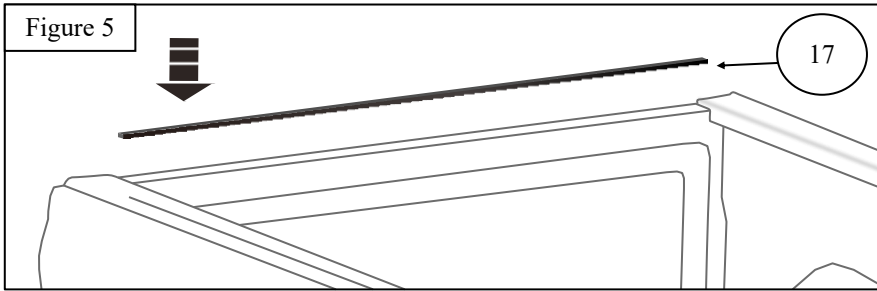

7. Remove the protective plastic wrapping from the side rails and identify the Driver and Passenger Side Rails (**Items 3 & 4**). See **Figure 12**.
8. Carefully pull the tonneau cover out from the canister and ensure the stopper on the tonneau cover is in front of the limit block on the canister. See **Figure 13**.

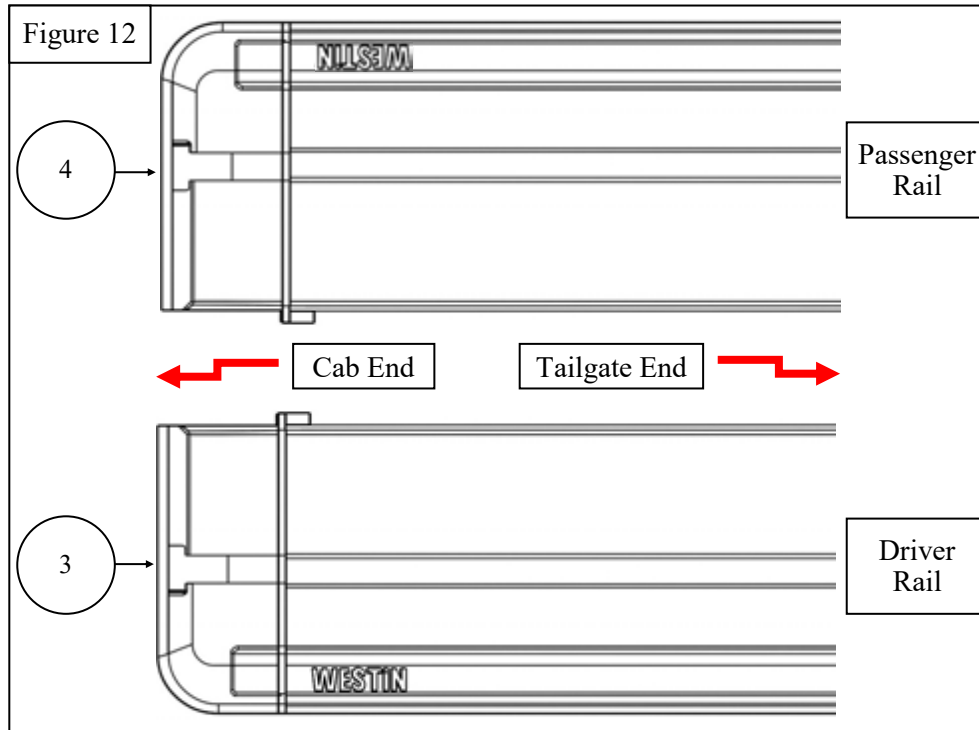

WESTIN

Westin Automotive Products, Inc.
320 W. Covina Blvd
San Dimas, Ca. 91773

Thank you for choosing Westin products
for additional installation assistance please call
Customer Service (800) 793-7846

www.westinautomotive.com

DATE: 01/13/2026

9. Starting on the Passenger Side, line up the rail with the canister and carefully slide it inward into position, ensuring that the ends of the tonneau cover slats are properly inserted into the side rail channel. It may be necessary to lift a portion of the side rail sweep seal so that it stays on top of the cover slats and does not get tucked in. See **Figures 14 & 15**.
10. Check that the side rail is sitting flush on top of the canister, then use 5 M6 x 16MM Torx Combo Bolts (**Item 21**) to install the side rail onto the canister. See **Figures 16-19**.
11. Repeat **steps 9 and 10** for the Driver Side Rail (**Item 3**).

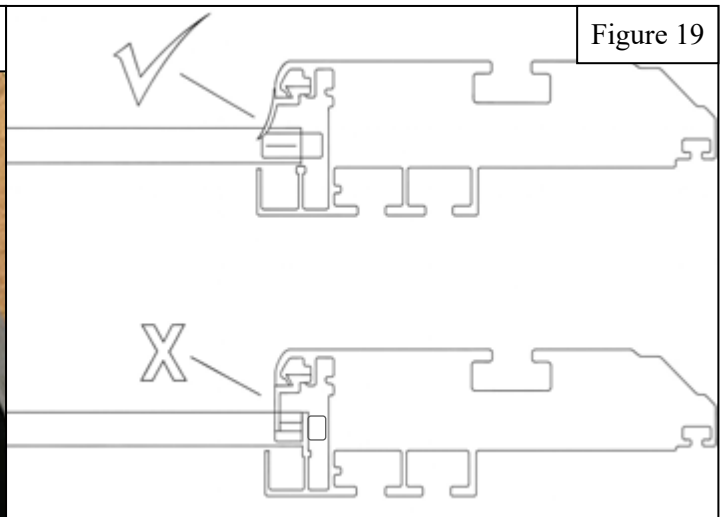
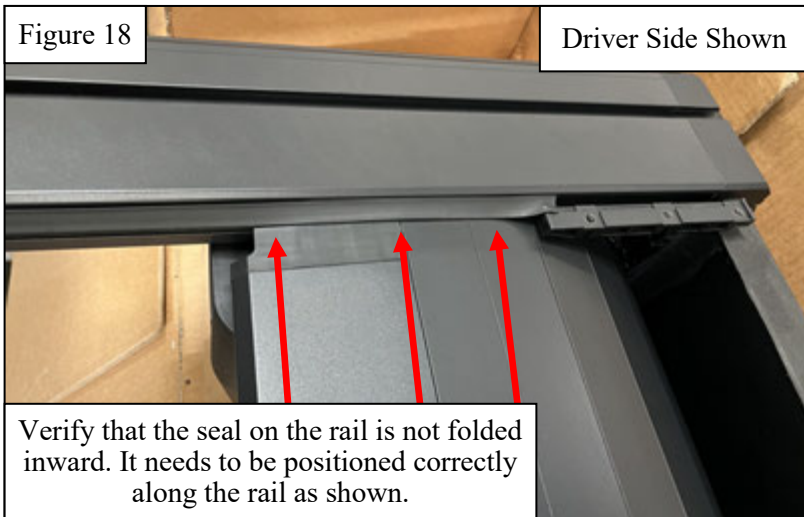
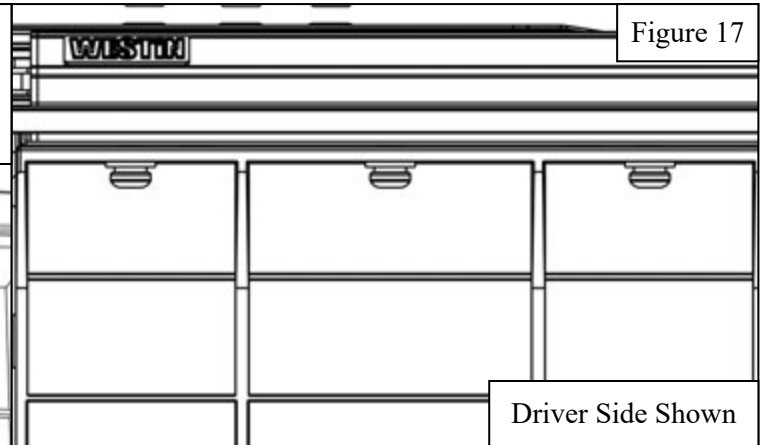
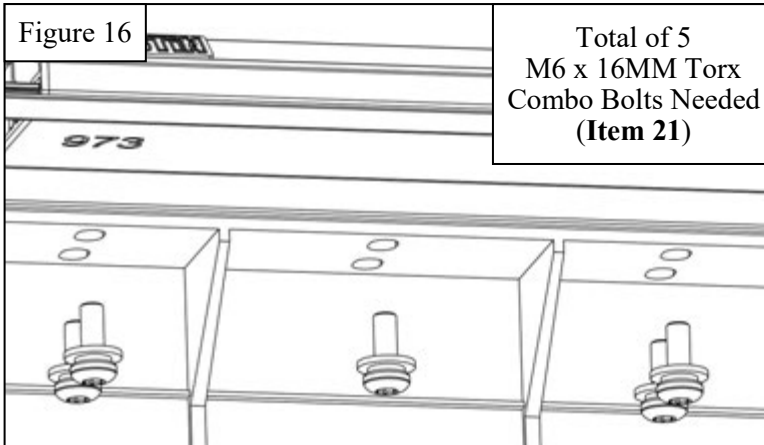
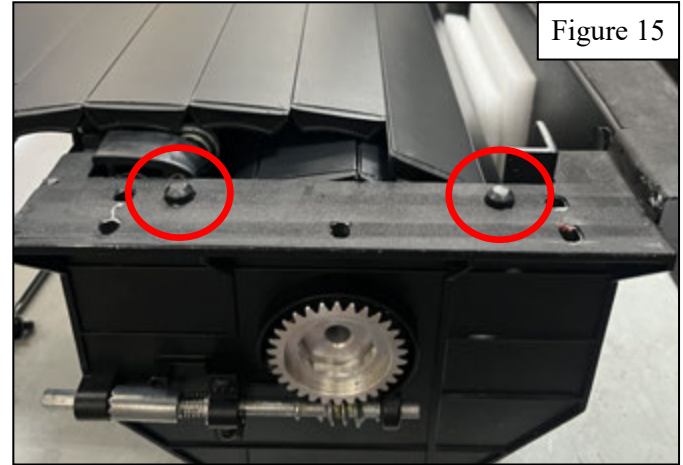
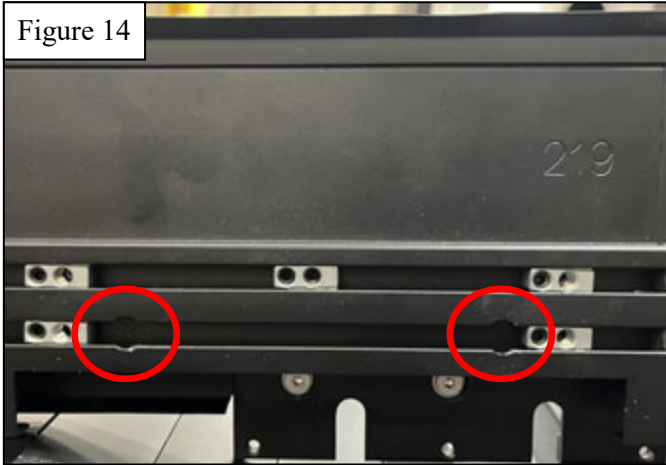

12. Install the Canister Cover Plate (**Item 2**), place the canister cover plate on top of the canister and ensure the mounting holes align with the mount points on the canister. Place one Plastic Ring (**Item 27**) into each hole on the canister cover plate, then use 6 M5 Countersunk Bolts (**Item 28**) to attach the canister cover plate to the canister. Cover the 6 mounting holes using the provided Plastic Caps (**Item 29**). Use **Figures 20 and 21** as reference.
13. Remove the covering over the adhesive strips on the ends of the weather seal and press firmly onto the bottom of the side rails. See **Figure 22**.

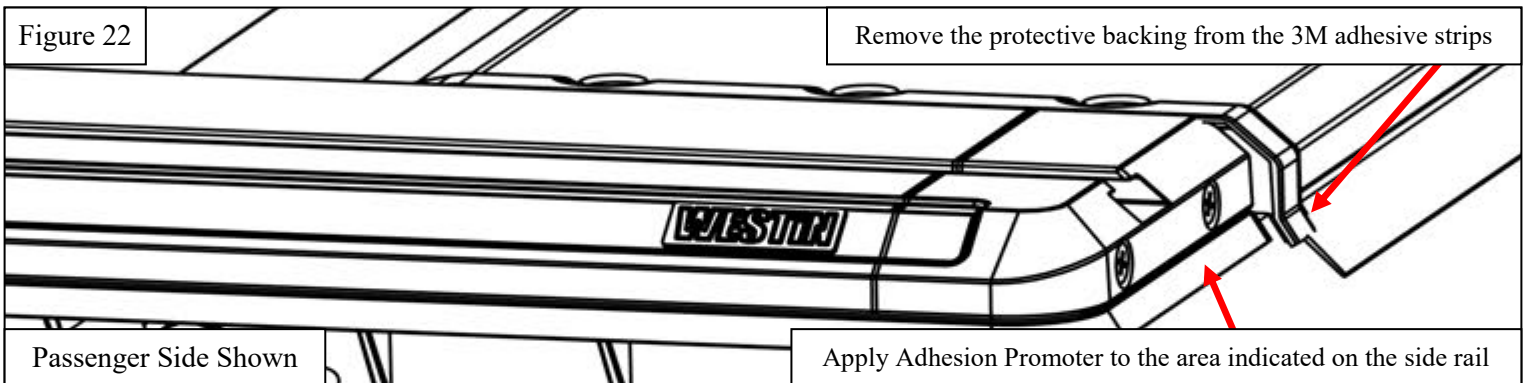
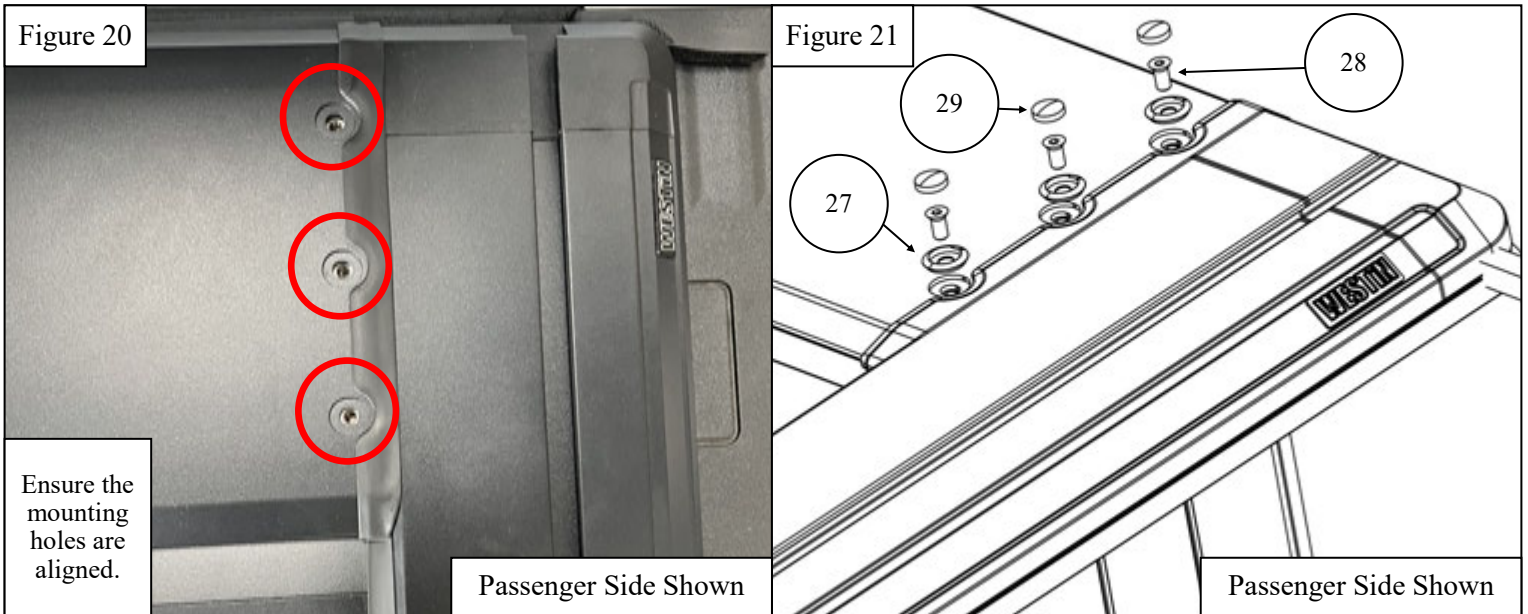

14. With assistance, carefully lift the tonneau cover assembly and place it on top of the truck bed. Do not slide the tonneau cover along the bed surface as this will damage the foam seals. While lifting the cover, position it as far forward as possible. See **Figure 23**.

Figure 23

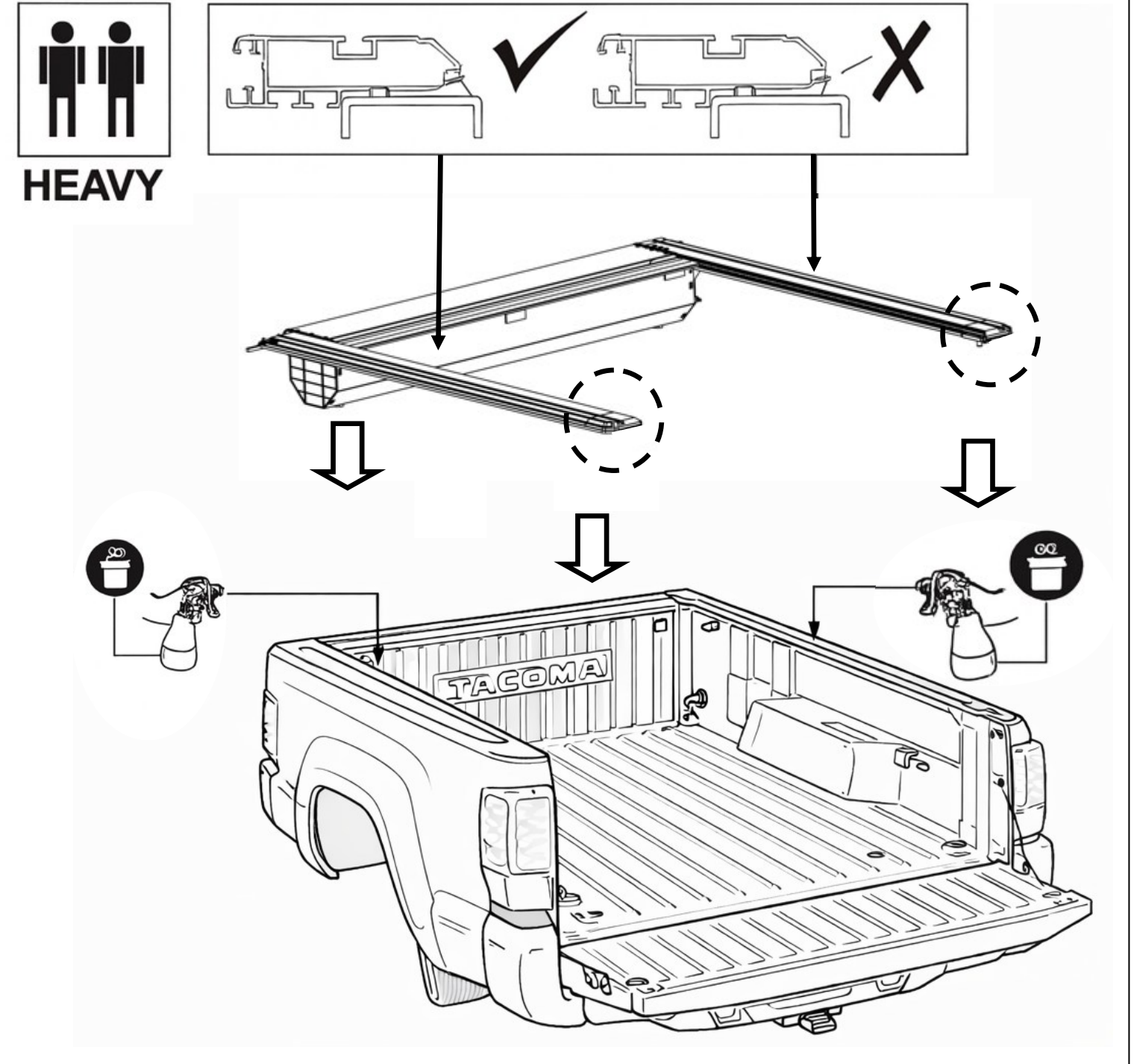

15. Starting on the Driver Side, insert 3 M6 T-Channel Nuts (**Item 20**) into the channel on the bottom of the rail. One for the rear bracket and two for the mounting brackets, evenly spaced along the rail. See **Figure 24**.
16. Attach 2 Mounting Brackets (**Item 6**) to the side-mounted rails by using the threaded mount blocks placed in **step 2** using 2 M8 Torx Bolts, Lock Washers, and Flat Washers per bracket. Move the T-Channel Nut Blocks to align with the mounting bracket locations, and use 1 M6 x 16MM Torx Combo Bolt (**Item 21**) per bracket to attach the mounting brackets to the nuts in the rail. See **Figures 25, 26, 29**.
17. Remove the two factory bolts located at the top of the rear bed wall. Use the Rear Driver Mounting Bracket (**Item 7**) to attach the cover to the truck bed. Use 1 M6 x 20MM Torx Combo Bolt (**Item 22**) and 1 M6 x 35MM Torx Combo Bolt (**Item 23**) to attach the bracket to the bed wall, and 1 M6 x 16MM Torx Combo Bolt (**Item 21**) to attach it to the aligned T-Channel Nut Block in the rail. Use **Figures 27-29** as reference.
18. Repeat **Steps 15-17** for the Passenger Side Rail and Brackets (**Items 6 & 8**).

NOTE: Leave all mounting bracket hardware loose.

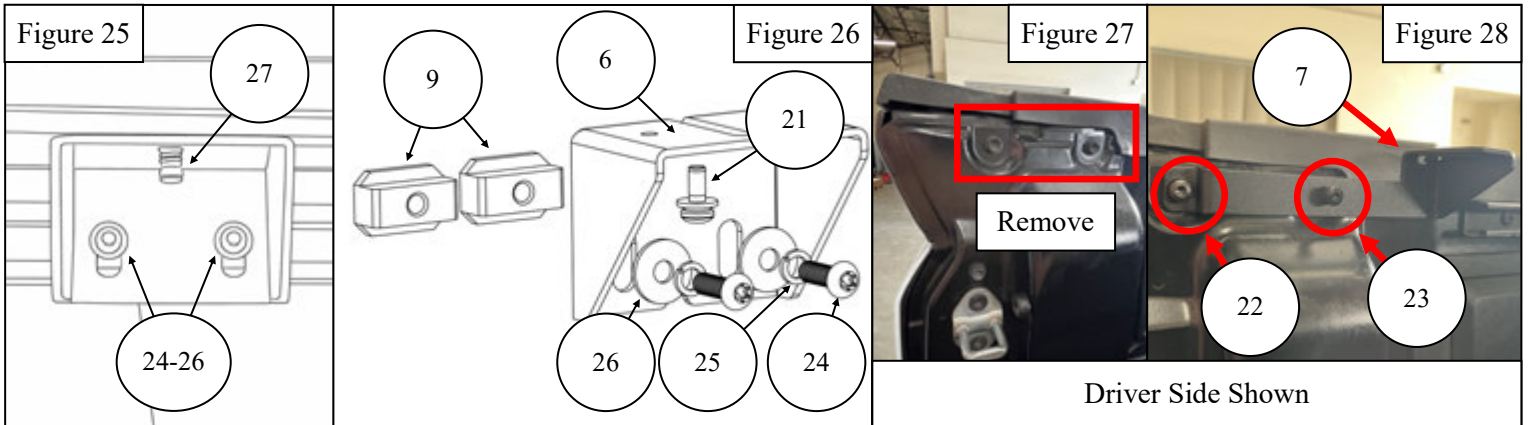
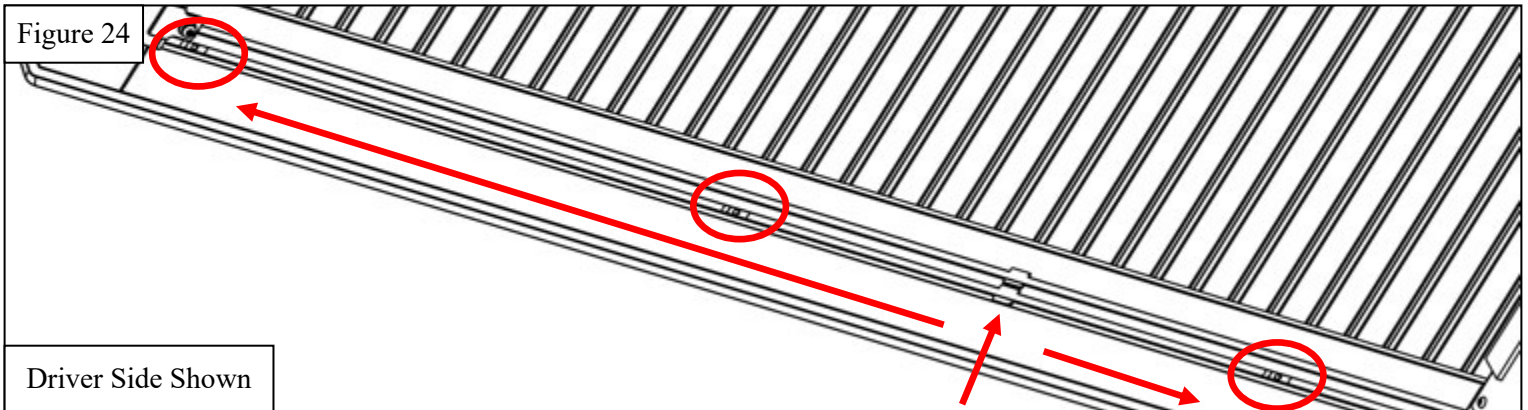

19. Align the side rails by using the Alignment Bar (**Item 5**). Insert the bar into the channel on the inner side of both side rails. Slide the alignment bar along the channels and check that the distance between the side rails is the same front-to-rear. Shift the ends of the side rails until the optimum position is achieved, then carefully push down on the end of the side rails and tighten the hardware for the rear mounting brackets. Use the alignment bar to double check the gap between the side rails and measure the distance between the outside of each side rail and the outer edge of the bed to ensure they are positioned centrally. This process may need to be repeated a few times until all measurements are optimal. After this has been completed, proceed to tighten the hardware for the front and center brackets, carefully pushing down on the side rails above each mounting bracket before tightening the hardware. As a final check, ensure the tonneau cover will operate smoothly. If it moves easily with no binding/ rough spots, proceed with the rest of the installation. If it is difficult to operate or has rough spots, the side rails will need further adjustment until the tonneau cover operates smoothly. See **Figures 30 and 31**.
20. Tighten all M5 hardware to 4-6 ft-lbs., M6 hardware to 7-11 ft-lbs., and M8 hardware to 17-26 ft-lbs.

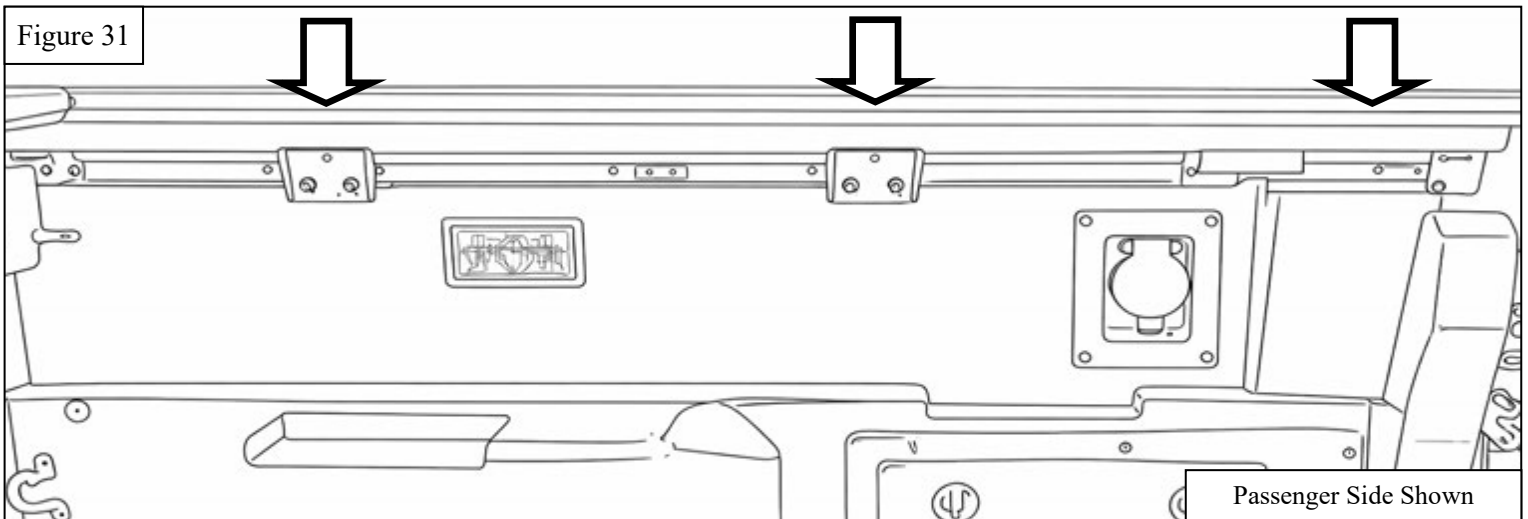
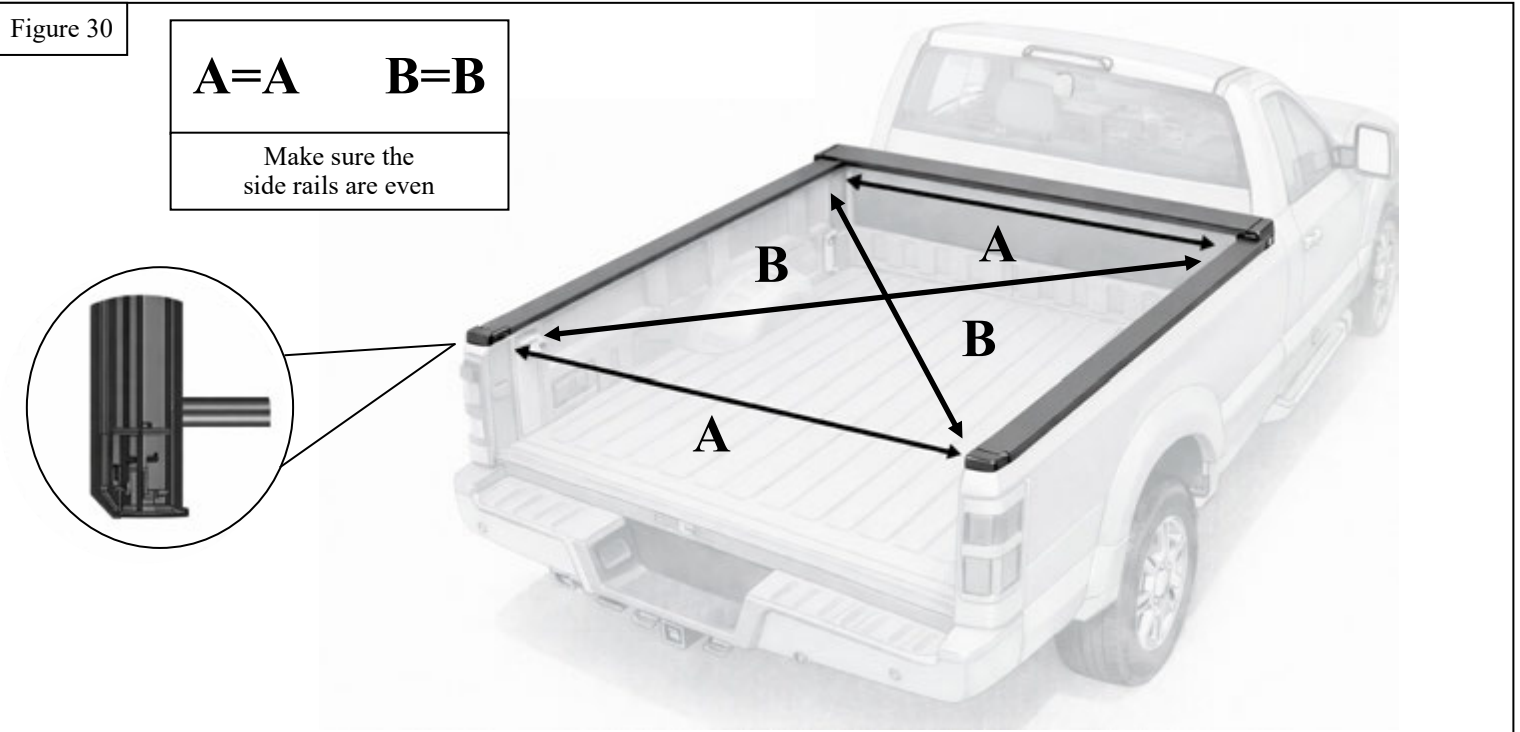

21. Starting on the Driver Side, install the Front Drain Tube Adapter (**Item 12**) onto the Front Drain Tube (**Item 10**) and tighten using the supplied Front Tube Clamp (**Item 14**). Place a Rubber Ring (**Item 13**) into the threaded mounting hole on the bottom of the canister then screw the drain tube adapter into the hole. See **Figure 32**.
22. Route the end of the Front Drain Tube through the hole that was cut into the front bed wall from **step 3**. See **Figure 33**.
23. Remove the tail light assembly by removing two bolts on the side of the tail light housing, then pull firmly outward to release the tabs. Slip the end of the Rear Drain Tube (**Item 11**) with the pre-installed Rear Tube Clamp (**Item 15**) onto the drain outlet at the end of the side rail. See **Figures 34 & 35**.
24. Route the bottom of the rear drain tube through the holes that were drilled in **step 4**. Reach inside the space behind the tail light assembly and route the tube downward, ensure it is clear of the tailgate strut before continuing. Once this is done, reinstall the tail light assembly. Tighten the tube clamp until the drain tube is snug on the drain outlet. See **Figure 36**.
25. Repeat **Steps 21-24** for the Passenger Side.

NOTE: Do not over-tighten the front drain tube adapter as this may damage the plastic fittings, and the tube clamps as this may cause damage to the drain outlet.

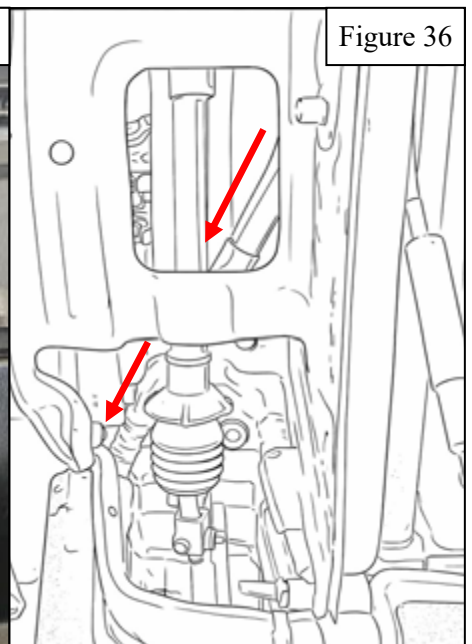
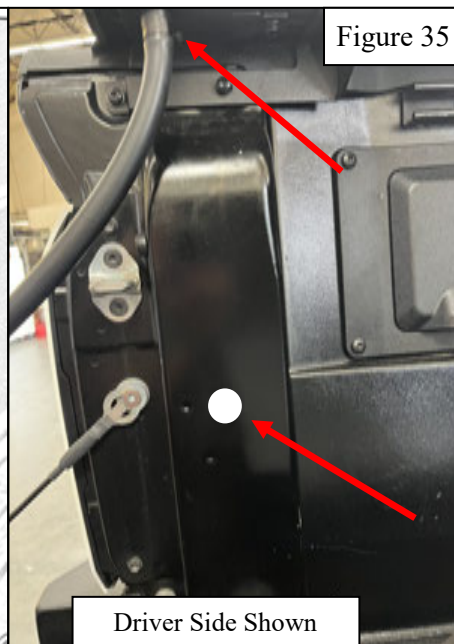
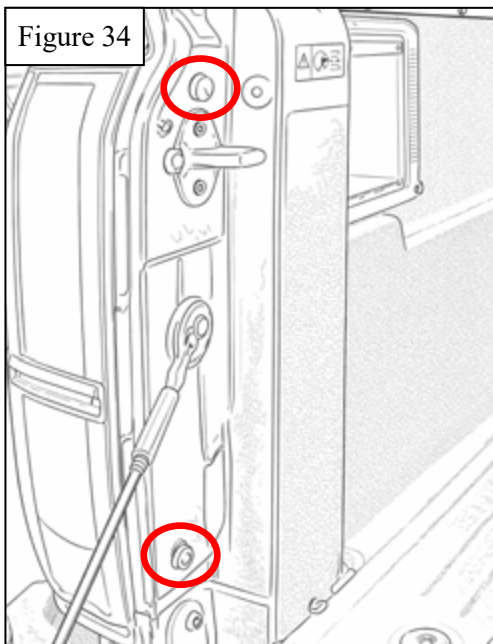
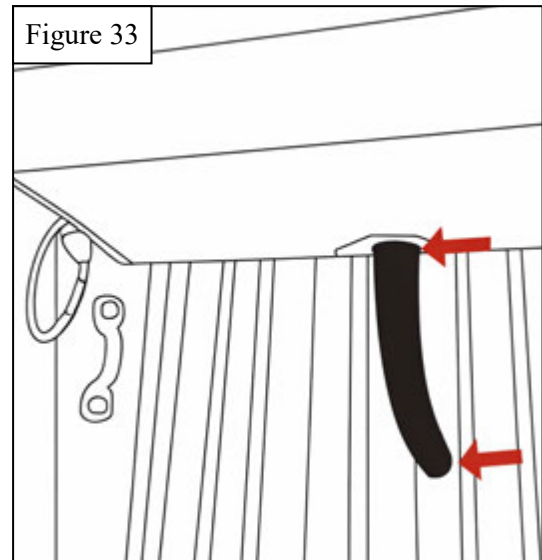
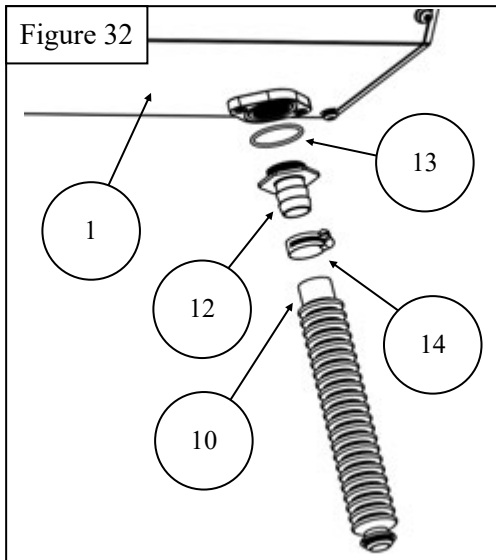

LOCK & UNLOCK INSTRUCTIONS

26. Swing the pull cord to the left to lock the cover. To unlock, swing the pull cord to the right. See **Figures 37 & 38**.

NOTE: Make sure the pull cord remains horizontal when locking or unlocking the cover. See **Figure 39**.

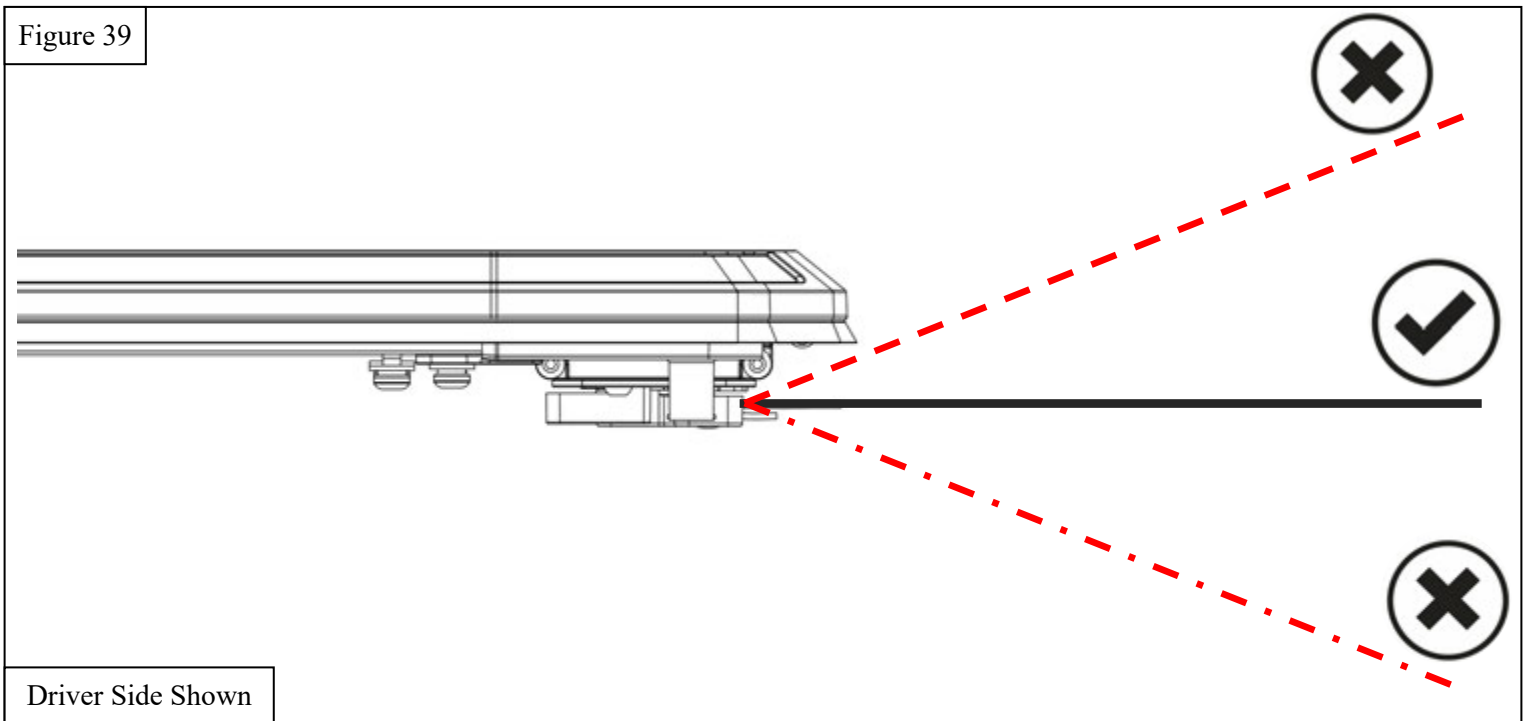
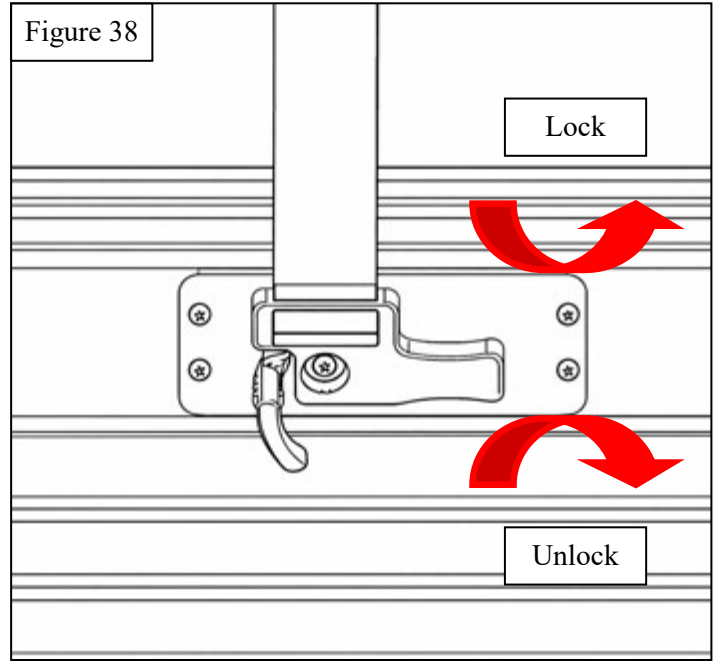
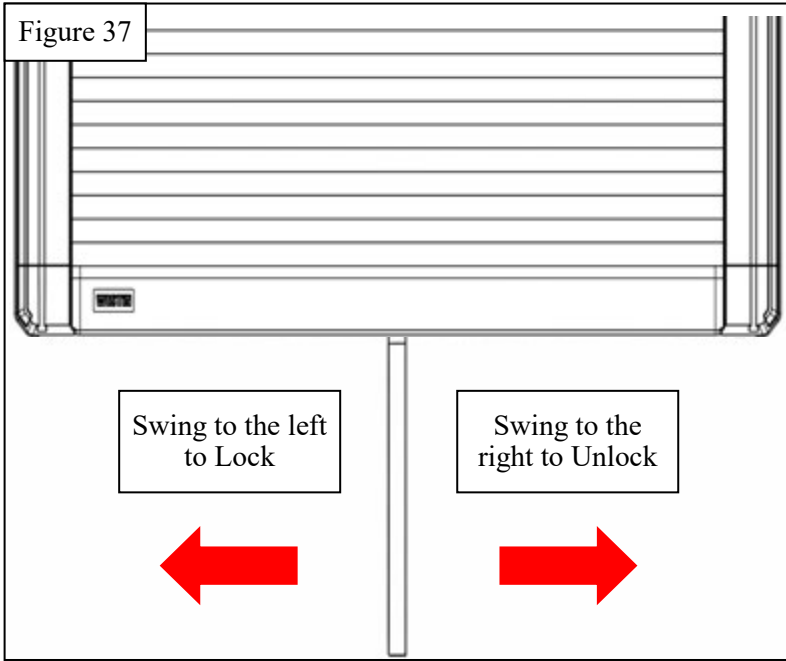
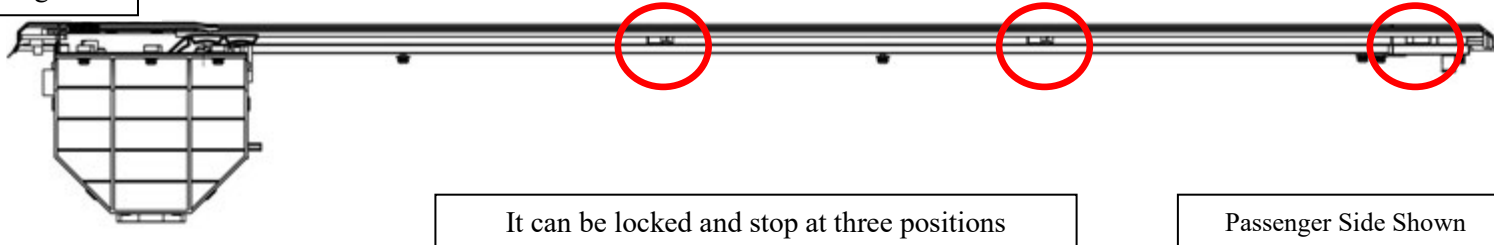

Figure 40



IMPORTANT MAINTENANCE NOTES

- 27. Grease the inner track of the side rails. See **Figures 41 & 42** as reference.
- 28. To adjust the tightness of the spring, push the worm inward and then rotate it. See **Figures 43 & 44**.

NOTE: These two steps should be carried out every 3 months for product maintenance and calibration. If there are special circumstances, the maintenance and calibration periods can be shortened according to the actual situation to ensure the product is always in the optimal working conditions.

Figure 41

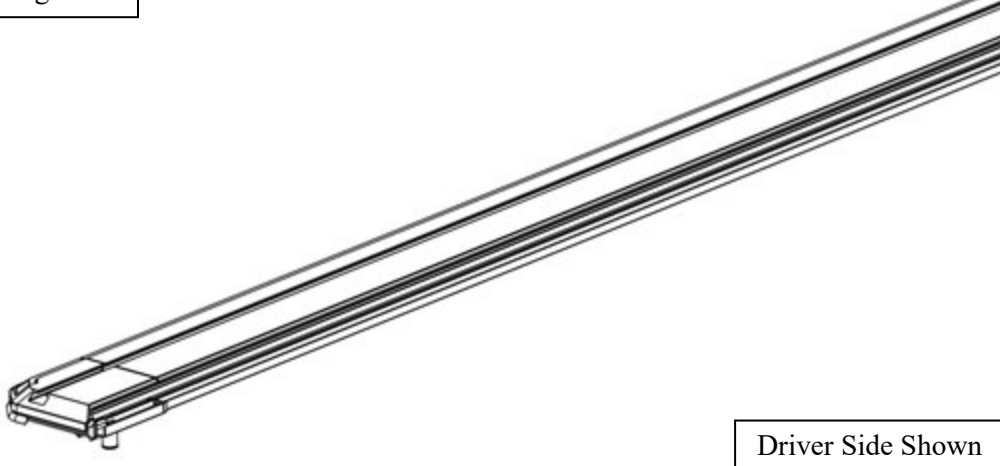

Figure 42

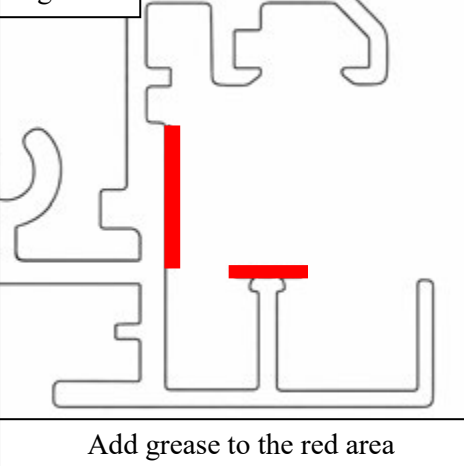

Figure 43

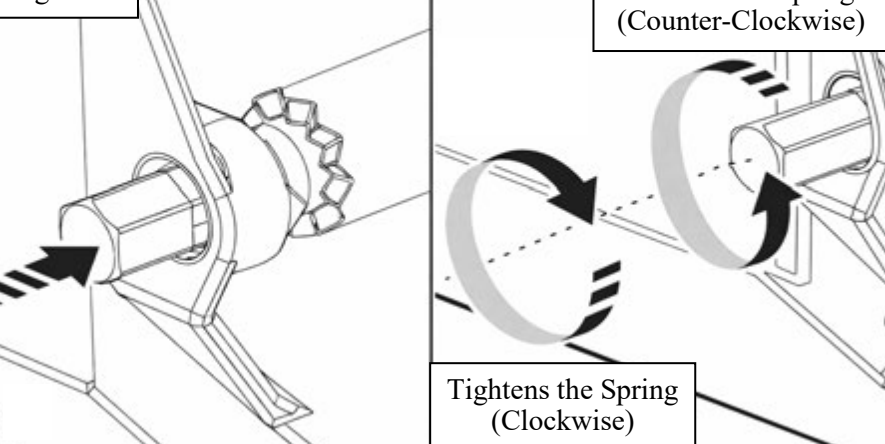
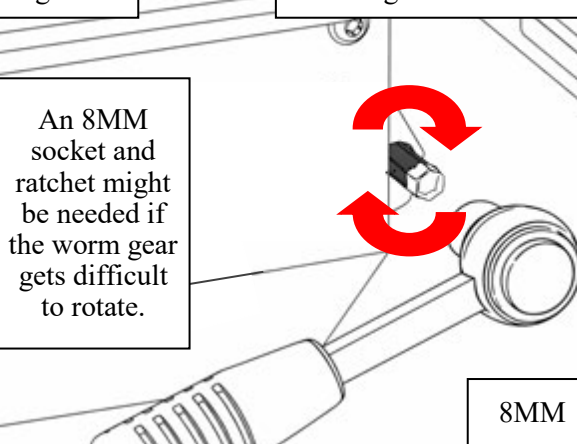

Figure 44



INSTALLATION COMPLETE



CARE INSTRUCTIONS

- TEXTURE BLACK FINISHES SHOULD BE CLEANED WITH MILD SOAP AND WATER ONLY (DO NOT WAX).
- GLOSS BLACK FINISHES SHOULD BE CLEANED WITH MILD SOAP AND WATER.
- POLISHED STAINLESS PRODUCTS SHOULD BE CLEANED WITH MILD SOAP AND WATER. STAINLESS STEEL POLISH MAY BE USED TO REMOVE SMALL SCRATCHES.
- REGULAR WAXING IS RECOMMENDED FOR GLOSS BLACK AND STAINLESS STEEL PRODUCTS. DO NOT USE WAX THAT MAY CONTAIN ABRASIVES.



WARNING



Failure to follow these instructions could lead to death, personal injury, and/or property damage.

FASTENERS:

All Westin supplied fasteners must be utilized and installed in accordance with the installation instructions and apply torque to the specifications as defined. **DOUBLE CHECK ALL FASTENERS BEFORE INITIAL USE, AND PERIODICALLY IN THE FUTURE TO ENSURE PROPER FUNCTION AND SAFETY.**

DRILLING:

Most Westin products do not require drilling for installation. If drilling is defined as required, use caution when drilling a vehicle. **FAILURE TO REVIEW AN AREA TO BE DRILLED MAY RESULT IN PERSONAL INJURY AND/OR INJURY TO OTHERS AS WELL AS VEHICLE DAMAGE.**

EYE PROTECTION:

ALWAYS WEAR SAFETY GLASSES OR GOGGLES DURING THE INSTALLATION PROCESS TO AVOID PERSONAL INJURY.

MAXIMUM TOWING/CARRYING CAPACITY: (if applicable)

The Westin Receiver Hitches will have a visible tow rating label affixed directly on the product. User should never exceed the vehicle manufacturer's maximum tow and weight rating regardless of the capacity of the hitch. **FAILURE TO FOLLOW THESE GUIDELINES WILL VOID THE WESTIN WARRANTY AND MAY RESULT IN PERSONAL INJURY AND/OR INJURY TO OTHERS AS WELL AS VEHICLE DAMAGE.**

FOR CALIFORNIA RESIDENTS ONLY-PROP 65 WARNING:

Some products may contain chemicals such as DEHP, which can cause cancer, birth defects or other reproductive harm. For more info go to www.p65warnings.ca.gov



Westin Automotive Products, Inc.
320 W. Covina Blvd
San Dimas, Ca. 91773