

INSTALLATION INSTRUCTIONS



ELECTRIC TONNEAU COVER

APPLICATION:
2019-2025 RAM 2500/3500 6.4' BED

PART NUMBER:
19-54025

CONTENT			
ITEM	QUANTITY	DESCRIPTION	TOOLS NEEDED
1	1	TONNEAU COVER CANISTER ASSEMBLY	PHILLIPS SCREWDRIVER
2	1	CANISTER COVER PLATE	FLAT SCREWDRIVER
3	1	DRIVER SIDE RAIL	SCISSORS
4	1	PASSENGER SIDE RAIL	TAPE MEASURE
5	1	ALIGNMENT BAR	T30 TORX BIT
6	1	DRIVER FRONT MOUNTING BRACKET	T40 TORX BIT
7	1	PASSENGER FRONT MOUNTING BRACKET	DRILL
8	2	CENTER MOUNTING BRACKET	
9	2	REAR CLAMP BRACKET	
10	2	CENTER SPACER NUT PLATE	
11	2	THREADED NUT PLATE	
12	1	MOTOR CLUTCH HANDLE	
13	1	POWER CABLE	
14	1	KEY FOB HOLDER	
15	2	KEY FOB REMOTE	
16	2	FRONT DRAIN TUBE ADAPTER	
17	2	FRONT DRAIN TUBE	
18	2	REAR DRAIN TUBE	
19	2	RUBBER RING	
20	2	FRONT TUBE CLAMP	
21	2	REAR TUBE CLAMP	
22	1	FRONT BED GAP FOAM SEAL	
23	3	TOP BED RAIL FOAM SEAL	
24	8	FASTENING BUCKLE	
25	10	NYLON TIES	
26	1	ADHESION PROMOTER	

ITEM	QUANTITY	DESCRIPTION	TOOLS NEEDED
27	1	THREADED INSERT TOOL	
28	14	M6 LONG TORX COMBO BOLT	
29	10	M6 SHORT TORX COMBO BOLT	
30	10	M6 T-CHANNEL NUT BLOCK	
31	4	M8 TORX BOLT	
32	4	M8 LOCK WASHER	
33	4	M8 FLAT WASHER	
34	4	M8 INSERT	
35	6	M5 COUNTERSUNK BOLT	
36	6	PLASTIC CAPS	
37	6	PLASTIC RINGS	

ANTI-SEIZE LUBRICANT MUST BE USED ON ALL STAINLESS STEEL FASTENERS TO PREVENT THREAD DAMAGE AND GALLING

Item 1

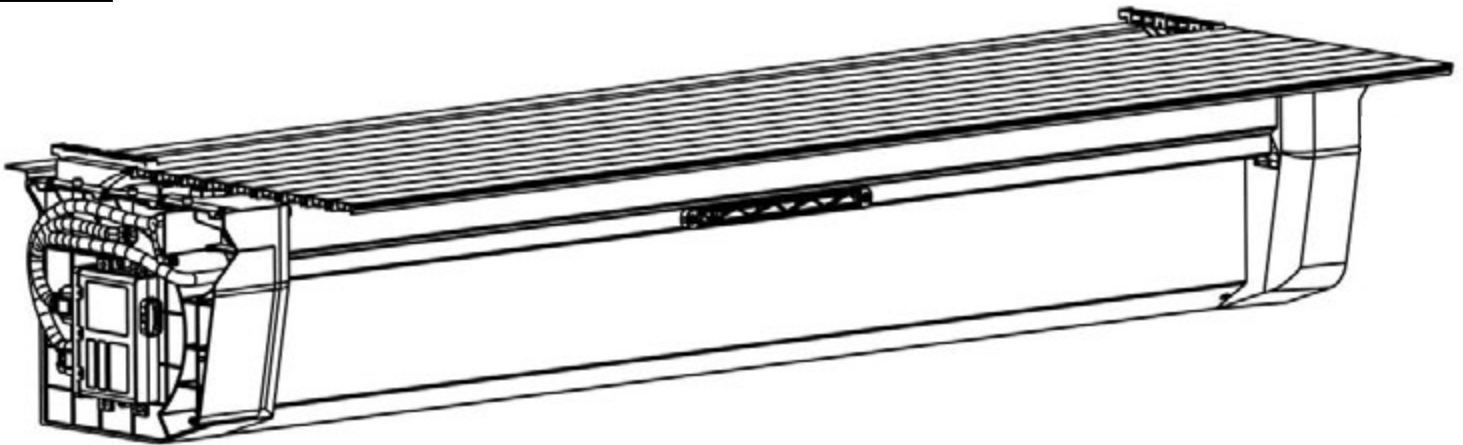

Item 2



Item 3



Passenger Side Opposite

Item 5



Item 6

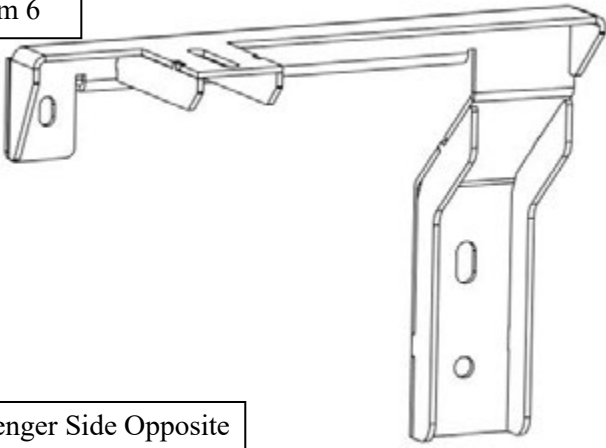

Item 8

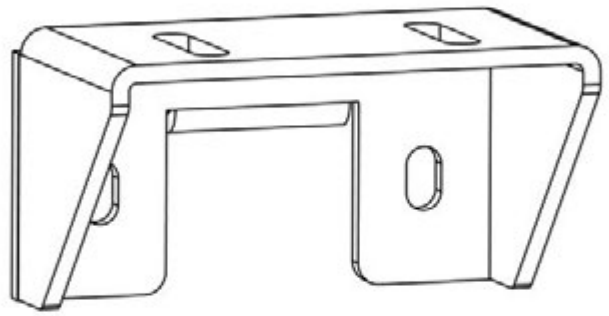

Passenger Side Opposite

Item 9

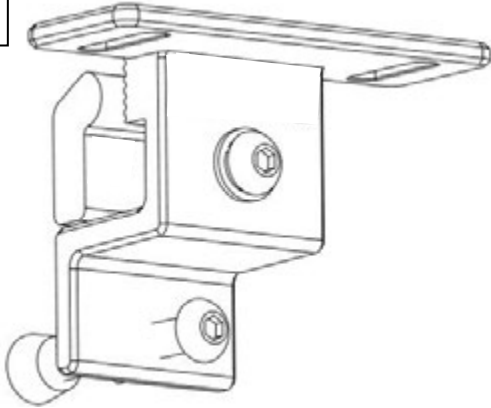

Item 10

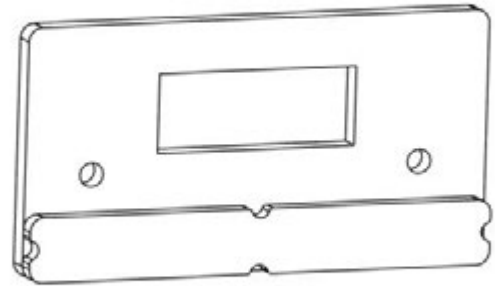

Item 11

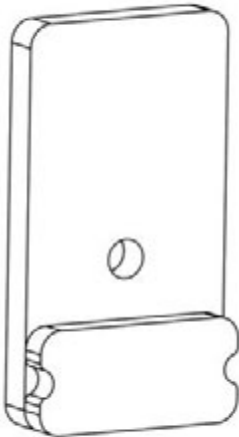

Item 12



Item 13



Item 14

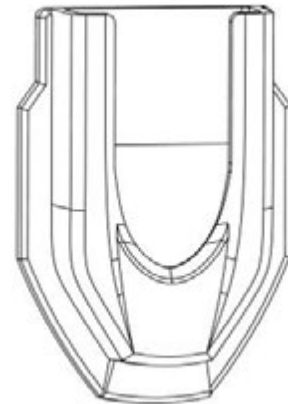

Item 15

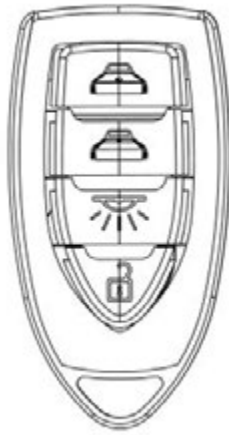

Item 16

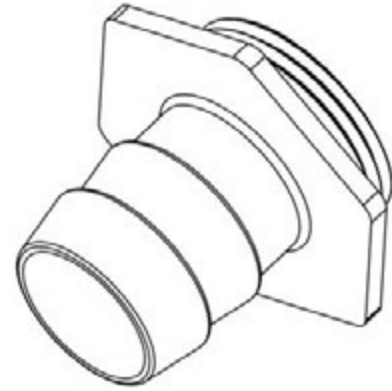

Item 17

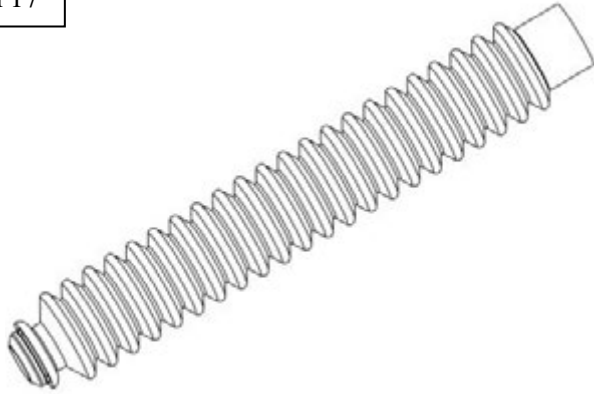

Item 18

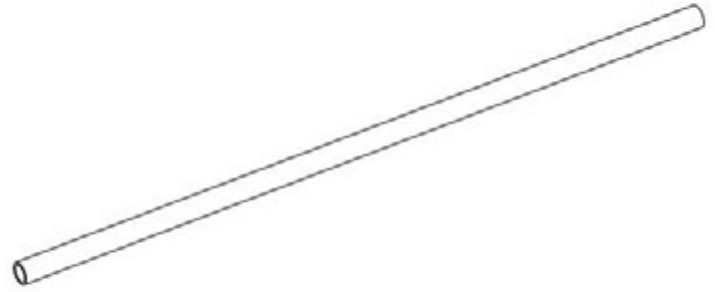

Item 19

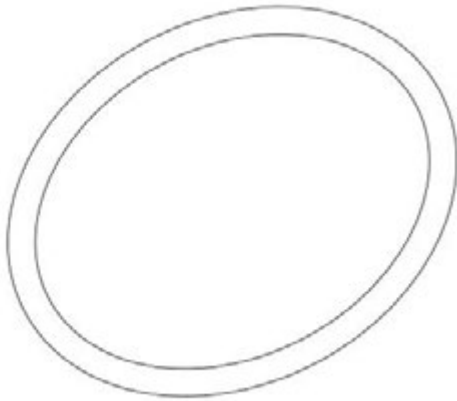

Item 20

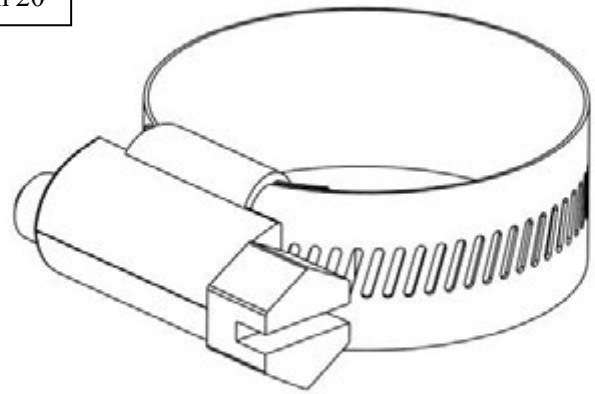

Item 21

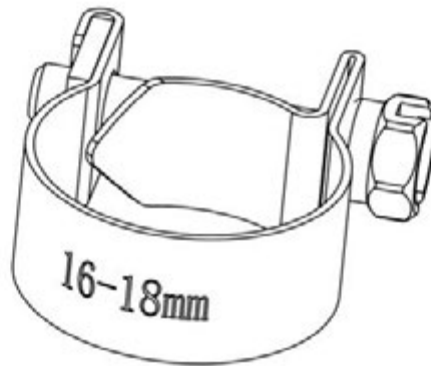

Item 22



Hard Foam Seal

Item 23



Soft Foam Seal

Item 26



Item 27

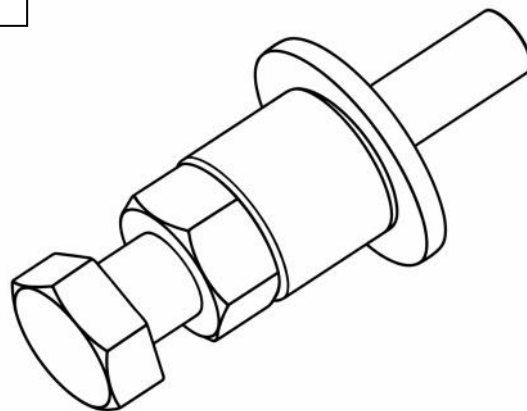

PROCEDURE

1. Remove contents from the box, verify that all parts listed are present and free from damage. Carefully read and understand all instructions before attempting installation.
Failure to identify damage before installation could lead to a rejection of any claim.



Westin Automotive Products, Inc.
320 W. Covina Blvd
San Dimas, Ca. 91773

Thank you for choosing Westin products
for additional installation assistance please call
Customer Service (800) 793-7846
www.westinautomotive.com

**BEFORE STARTING THE INSTALLATION OF THE PRODUCT
PREPARATION OF THE BED MAY BE REQUIRED PRIOR TO INSTALLATION.**

2. Starting on the Driver Side, if the truck is equipped with tie down hooks, remove the front hooks on both the driver and passenger side. See **Figure 1**.
3. If the vehicle does not have factory inserts in the bed, position the Driver's Front Mounting Bracket (**Item 6**) and use the holes in the bracket to mark the locations to drill. Remove the bracket and drill the holes out to 7/16". Install 2 M8 Inserts using the provided Threaded Insert Tool (**Item 27 and 34**). See **Figure 2**.

NOTE: It may help to start with a smaller hole and progressively work up to the correct diameter.

4. Loosely install the Drivers Front Mounting Bracket to the bed wall using 2 sets of M8 hardware (**Items 31-33**), and use a Threaded Nut Plate and a M6 Long Torx Combo Bolt (**Items 11 and 28**) to loosely attach the bracket to the lip of the bed wall. See **Figures 3 and 4**.
5. Repeat **Steps 2-4** for the Passenger Side of the vehicle.

Figure 1

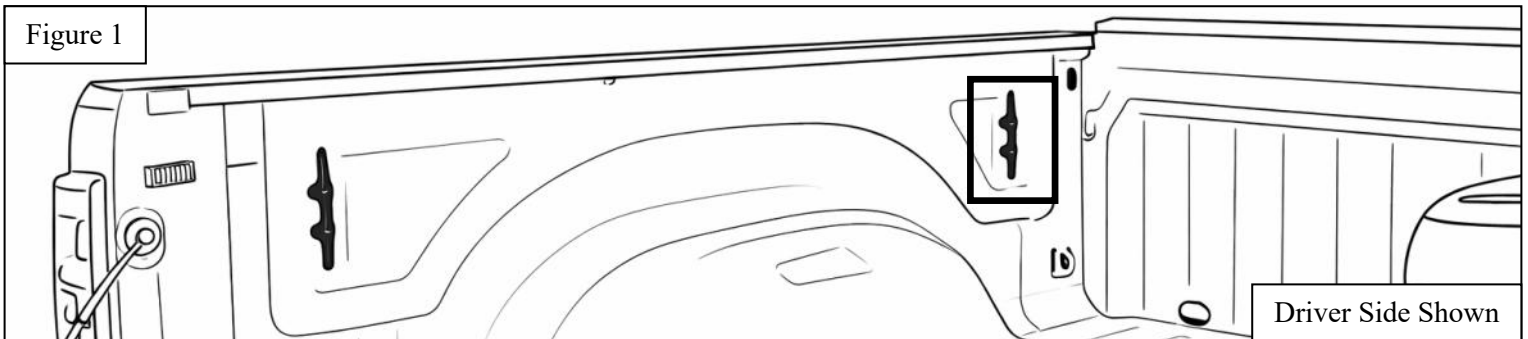

Driver Side Shown

Figure 2

Driver Side Shown

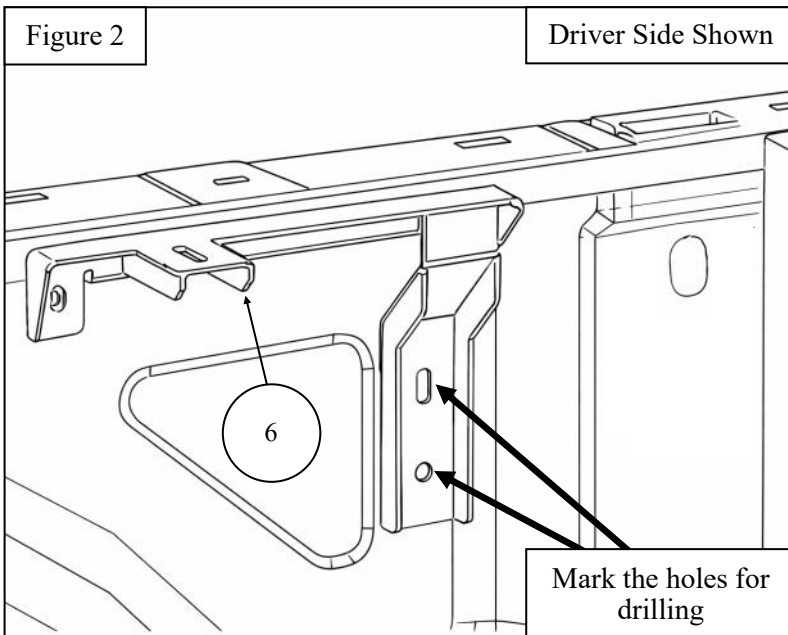

Mark the holes for drilling

Figure 3

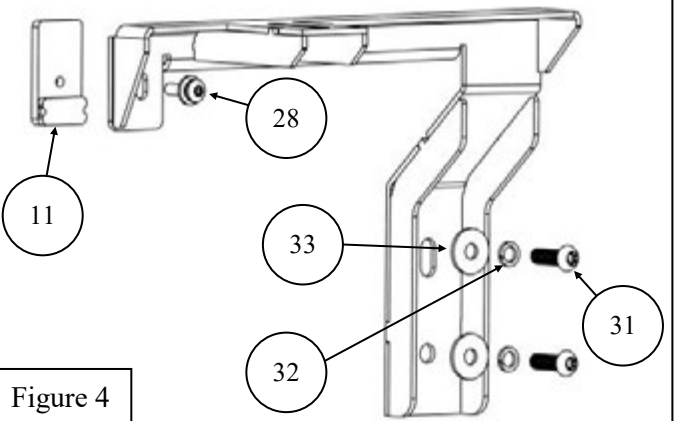
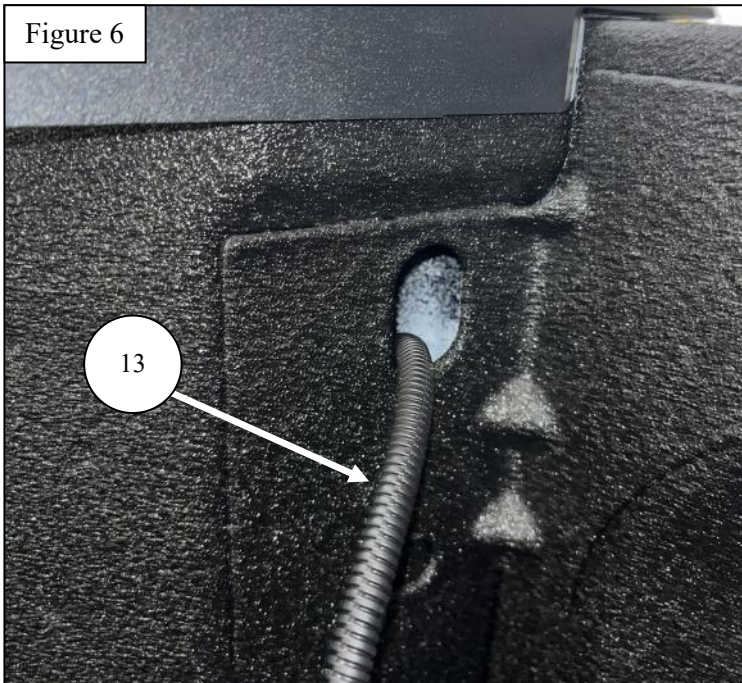
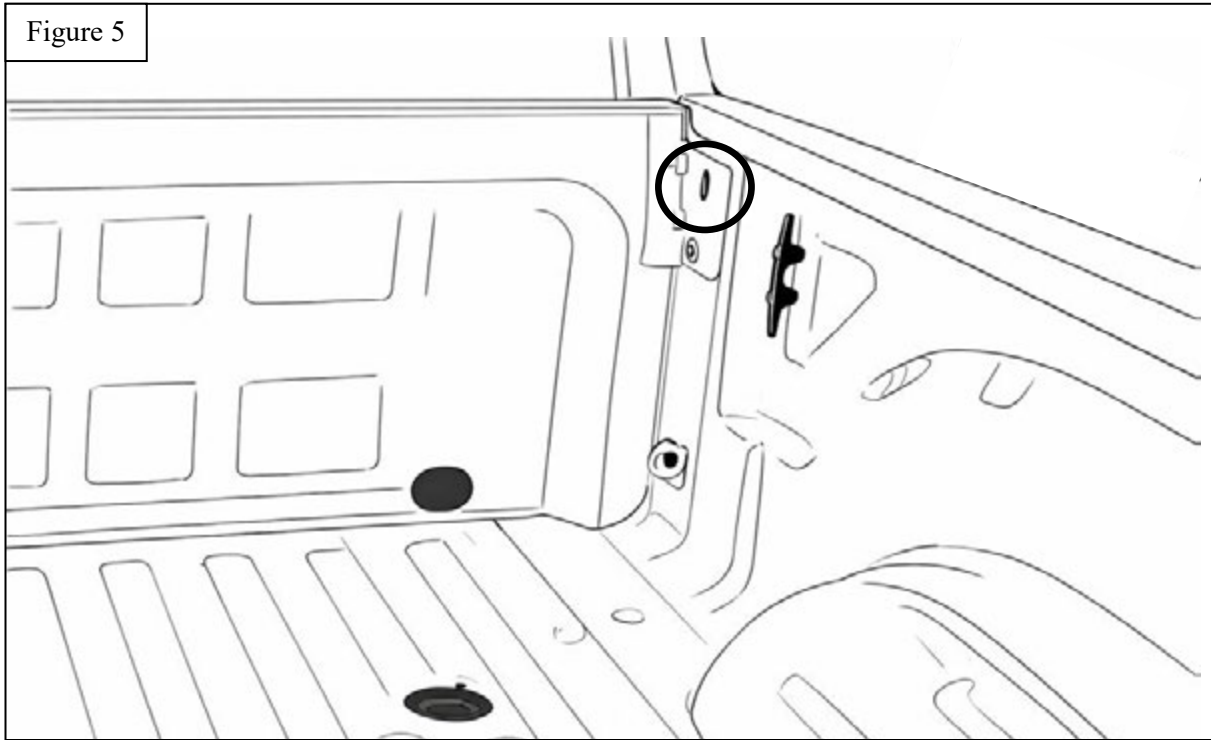

Figure 4

6. On the Driver Side, locate the hole towards the top of the bed wall and run half the length of the Power Cable (**Item 13**) through it. See **Figures 5-7**.

NOTE: Make sure to leave enough Power Cable length to be able to adjust it accordingly and connect it to the Tonneau Cover once positioned.



7. Clean the top of the plastic bed caps and the top of the front bed bulkhead of dirt/debris. Install Front Bed Gap Foam Seal (hard foam seal, **Item 22**) across the top of the front bed wall. See **Figures 8-12**.
8. Install the Top Bed Rail Foam Seal (soft foam seal, **Item 23**) across the top of the front bulkhead (installed over the hard foam seal) and the plastic bed caps. A small amount of sealant may be used at the corners of the front bulkhead to improve water resistance. See **Figures 13 & 14**.

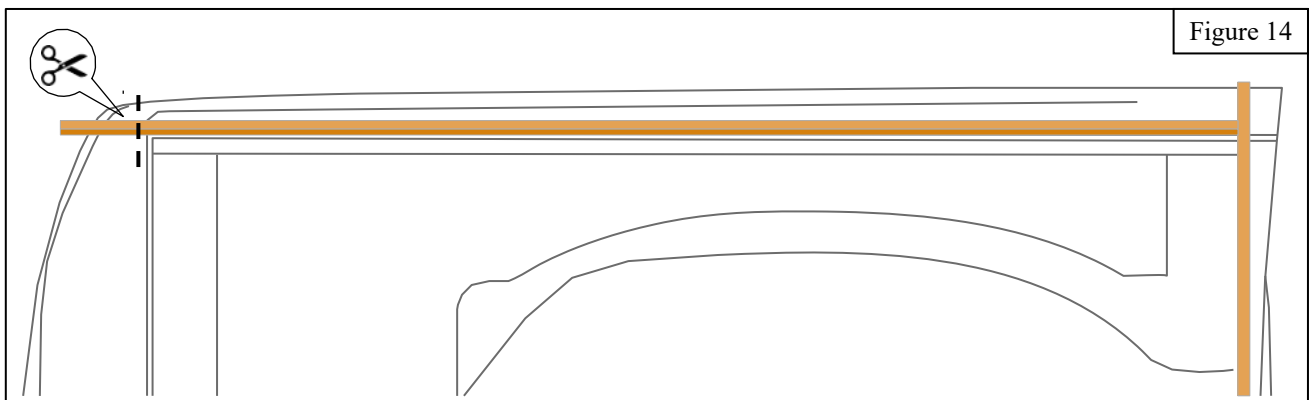
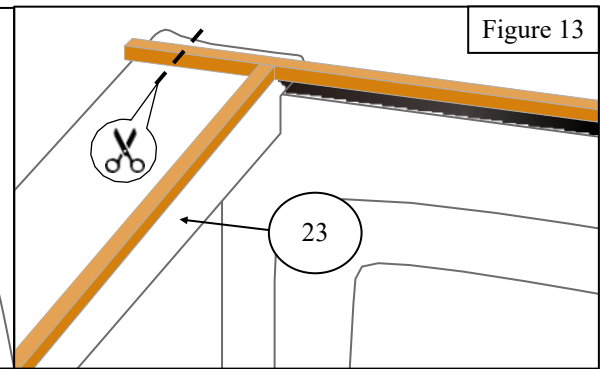
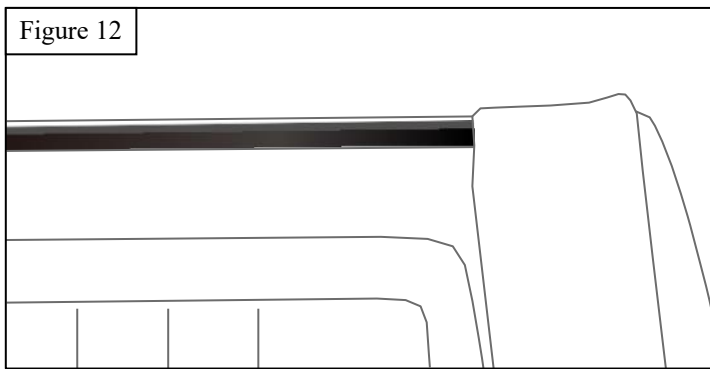
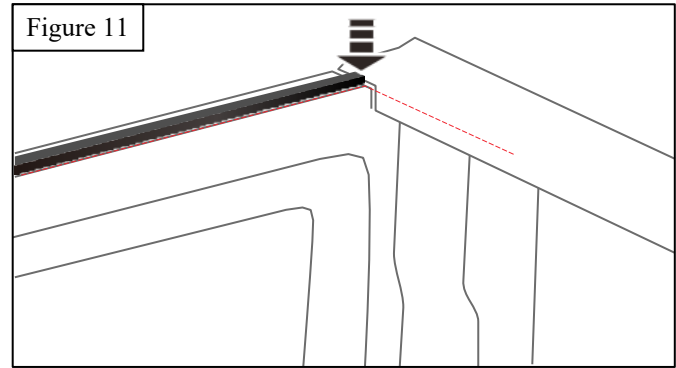
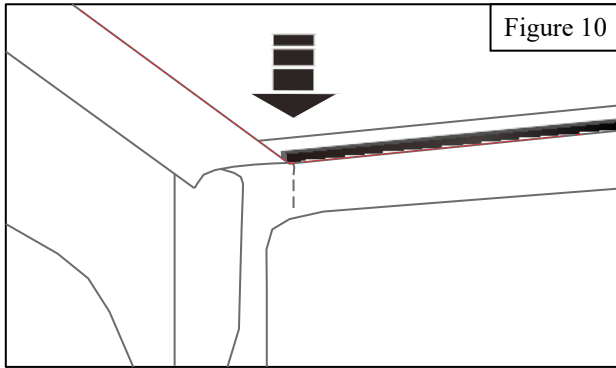
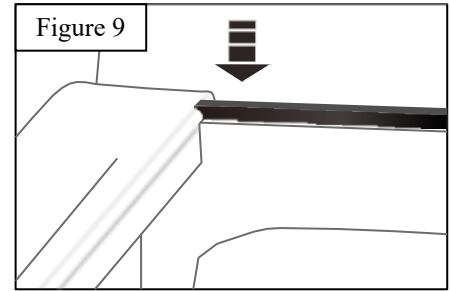
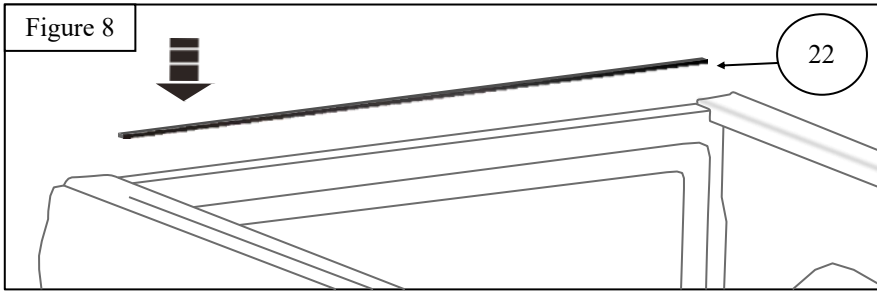

9. Install the Motor Clutch Handle (**Item 12**) onto the motor. If the handle moves up and down too easily, use a Phillips screwdriver to tighten the upper screw to increase the resistance. See **Figures 15 & 16**.

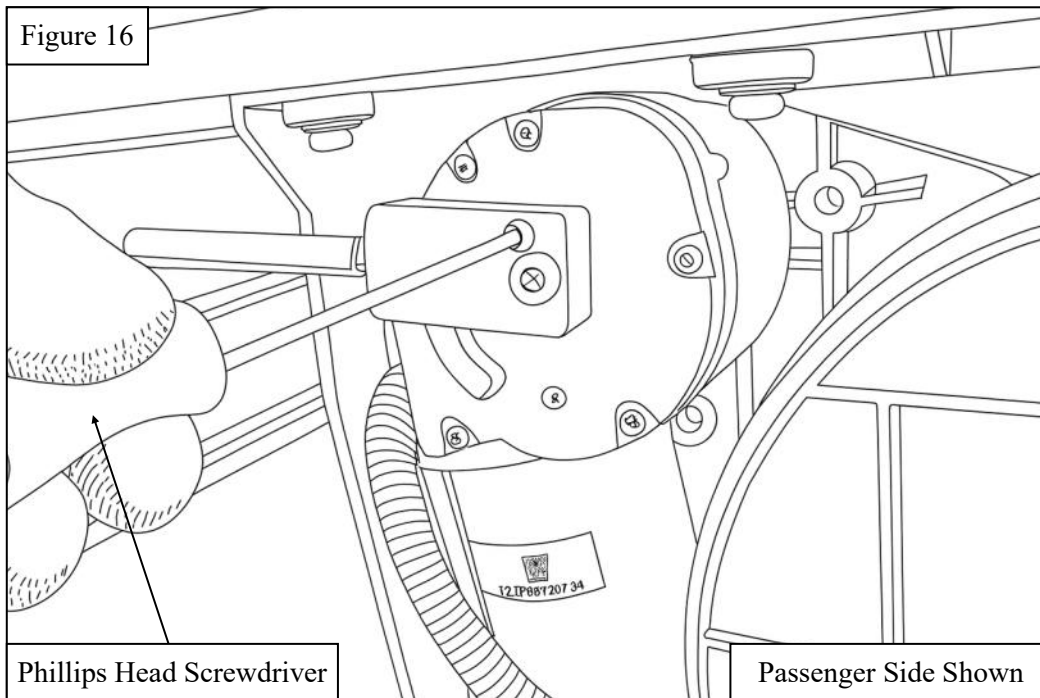
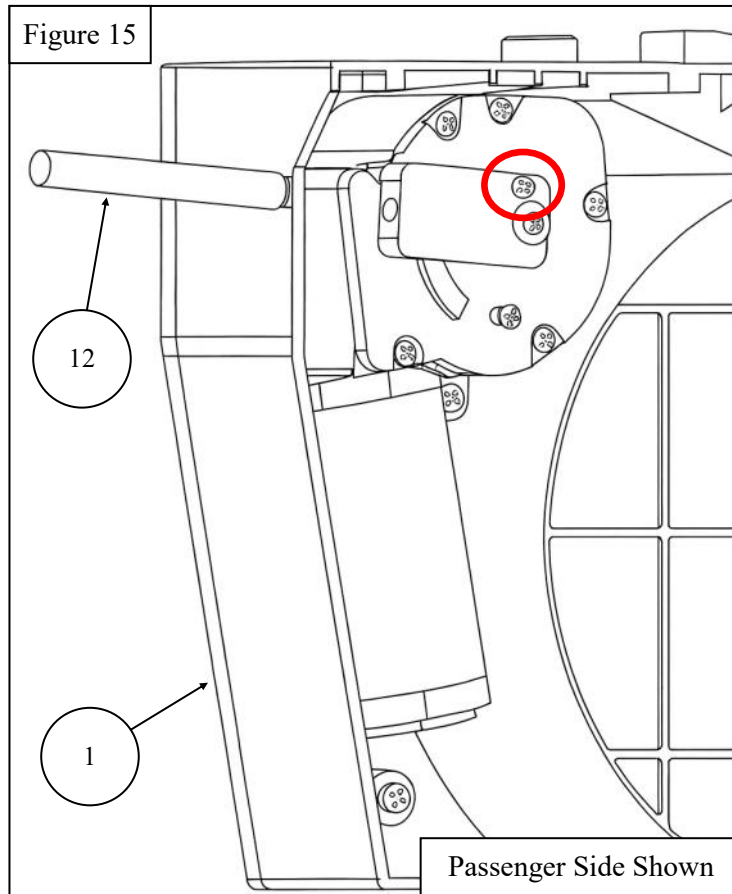

10. Remove the protective plastic wrapping from the side rails and identify the Driver and Passenger Side Rails (**Items 3 & 4**). See **Figure 17**.
11. Push the motor clutch handle down to disengage the motor, and carefully pull the tonneau cover out of the canister and ensure that the stopper on the tonneau cover is in front of the limit block on the canister. See **Figures 18 & 19**.

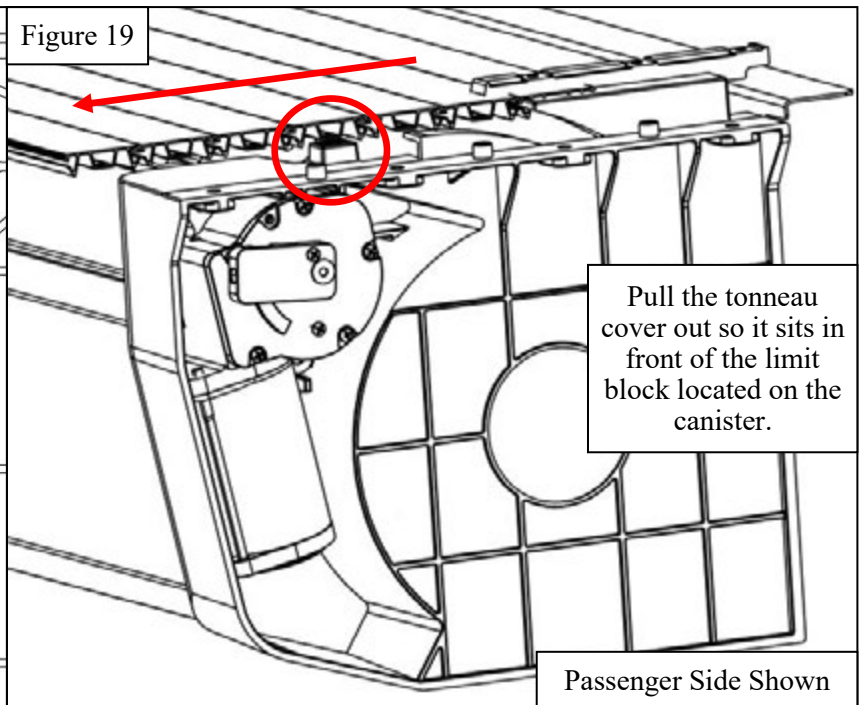
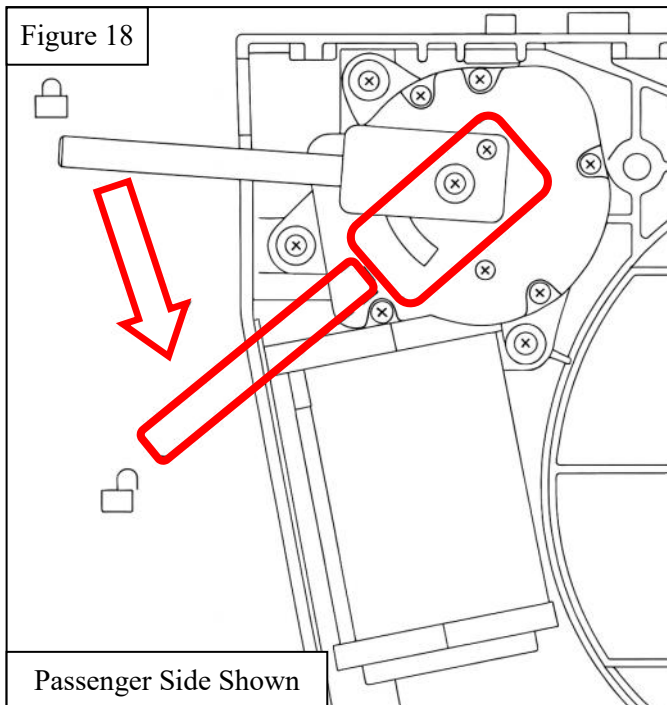
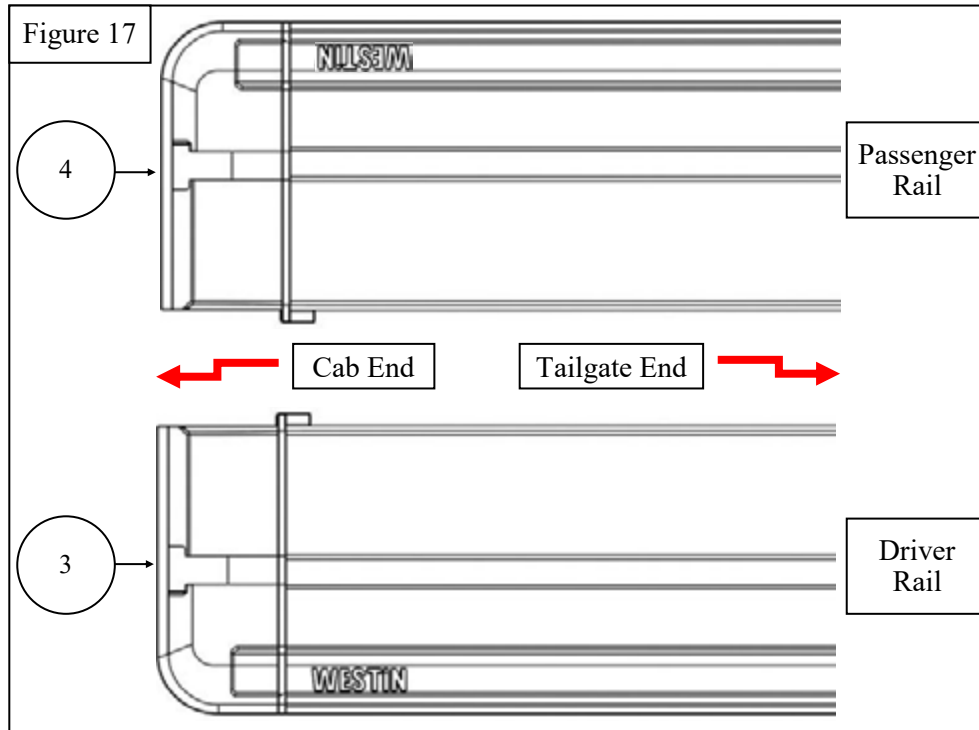

12. Starting on the Passenger Side, line up the rail with the canister and carefully slide it inward, ensuring that the ends of the tonneau cover slats are properly inserted into the side rail channel. It may be necessary to lift up part of the side rail sweep seal so that it stays on top of the cover slats and does not become tucked underneath. See **Figure 20**.
13. Check that the Passenger Side Rail (**Item 4**) is sitting flush on top of the canister, then use 4 M6 Long Torx Combo Bolts (**Item 28**) to install the side rail onto the canister. See **Figures 21-24**.
14. Repeat **Steps 12 and 13** for the Driver Side Rail (**Item 3**).

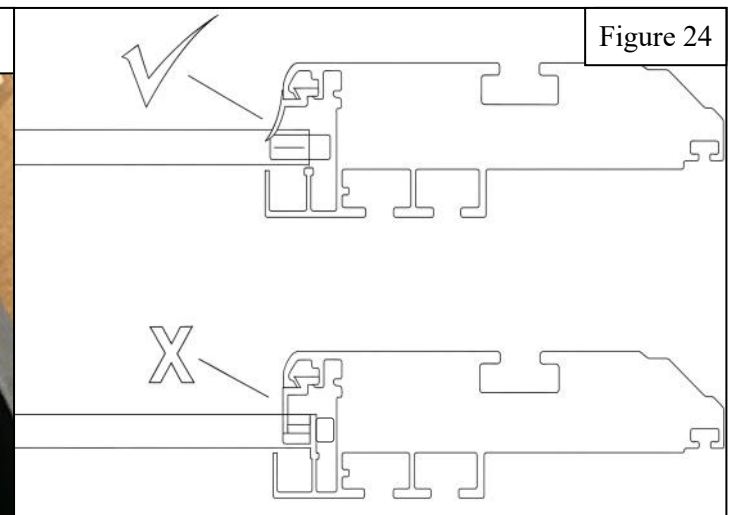
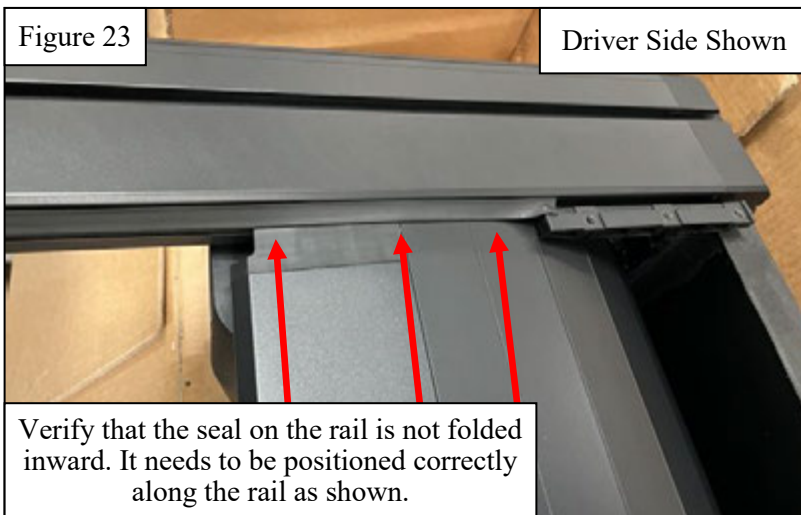
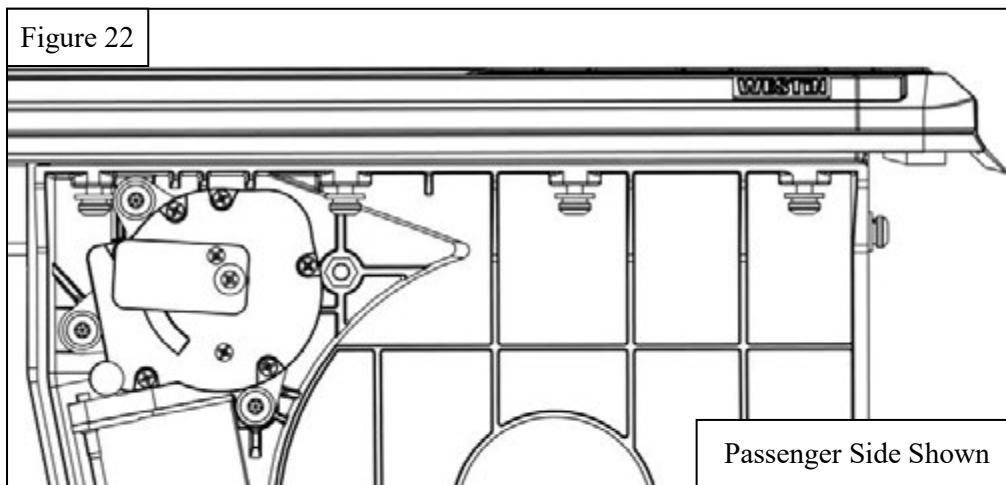
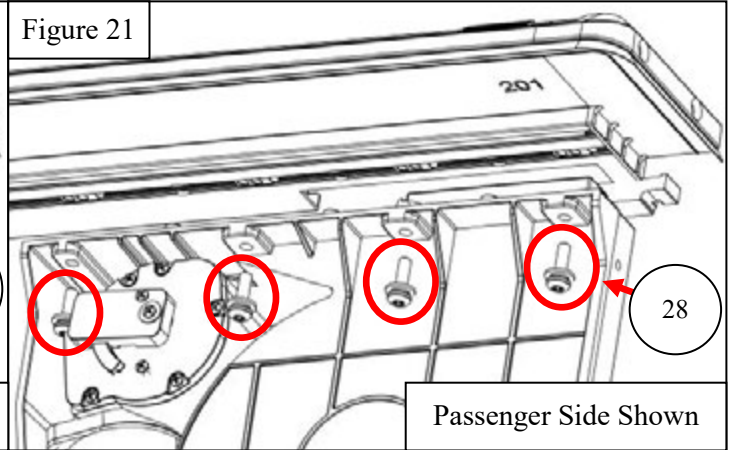
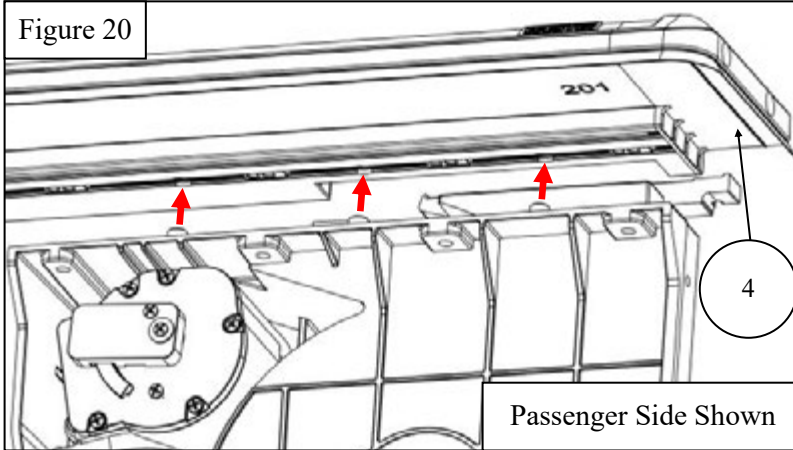

15. Pull the clutch handle upward to engage the motor. See **Figure 25**.
16. Install the Canister Cover Plate (**Item 2**), place the canister cover plate on top of the canister and ensure the mounting holes align with the mount points on the canister. Place one Plastic Ring (**Item 37**) into each hole on the canister cover plate, then use 6 M5 Countersunk Bolts (**Item 35**) to attach the canister cover plate to the canister. Cover the 6 mounting holes using the provided Plastic Caps (**Item 36**). Use **Figures 26 and 27** as references.
17. Remove the covering over the adhesive strips on the ends of the weather seal and press them onto the bottom of the side rails. See **Figure 28**.

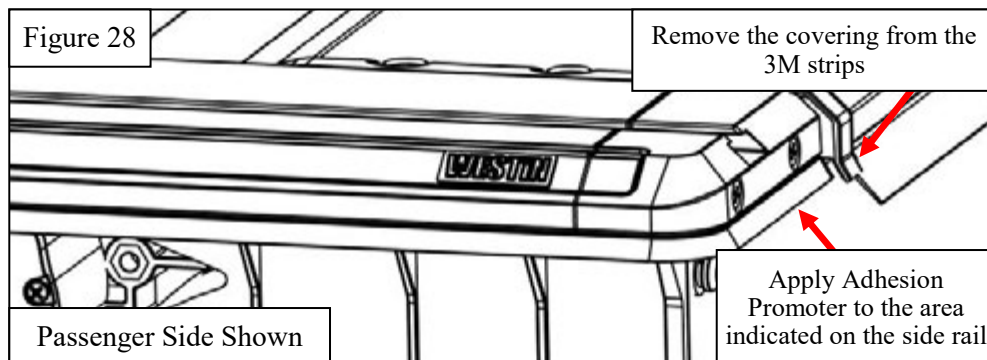
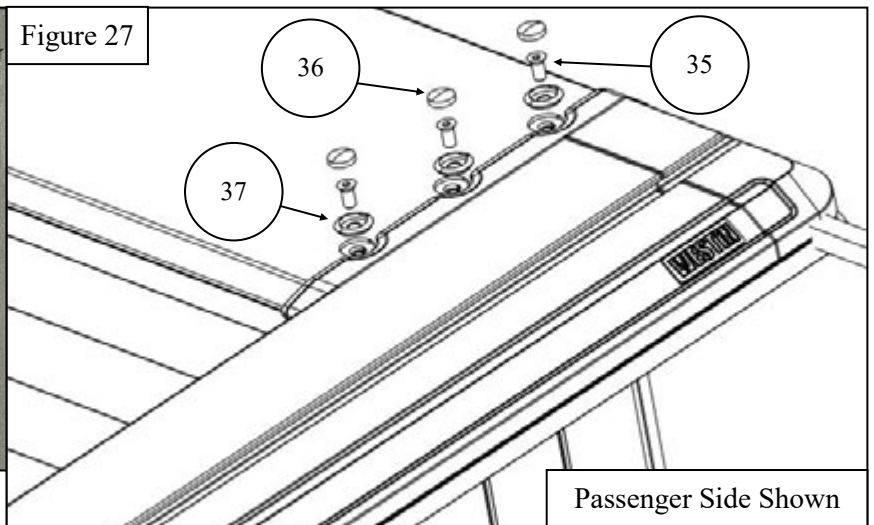
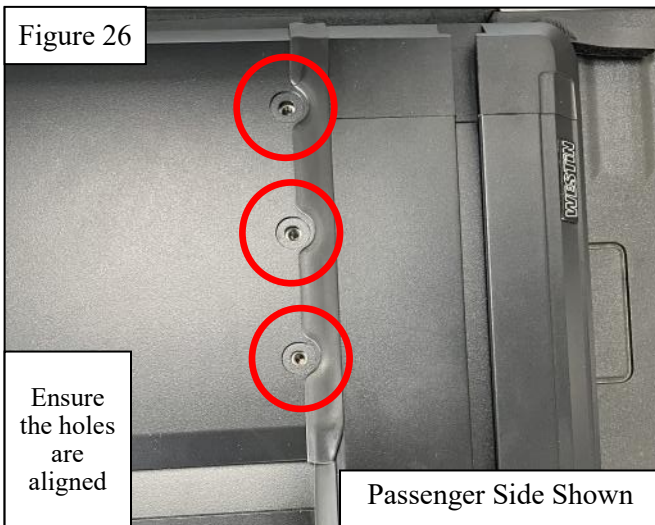
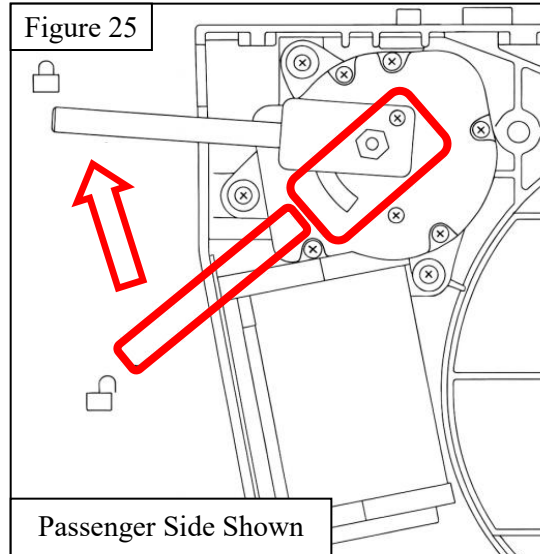

**THE ELECTRICAL WIRING FOR THIS TONNEAU COVER IS PRE-INSTALLED.
IF THE WIRING IS ALREADY CONNECTED, PROCEED TO PAGE 14.
IF THE WIRING IS NOT CONNECTED, FOLLOW THE STEPS BELOW BEFORE CONTINUING.**

18. Connect the two large connectors on the ECU main harness to the bottom of the ECU. See **Figure 29**.
19. Identify the smaller leads on the ECU main harness and connect each one to the corresponding lead on the tonneau cover/ side rails. See **Figure 29**.
20. Use the Fastening Buckles (**Item 24**) to organize the wire harness. At this time, the connector for the Power Cable (**Item 13**) needs to remain unplugged.

NOTE: All wire harness leads are labeled and have unique male/female connections.

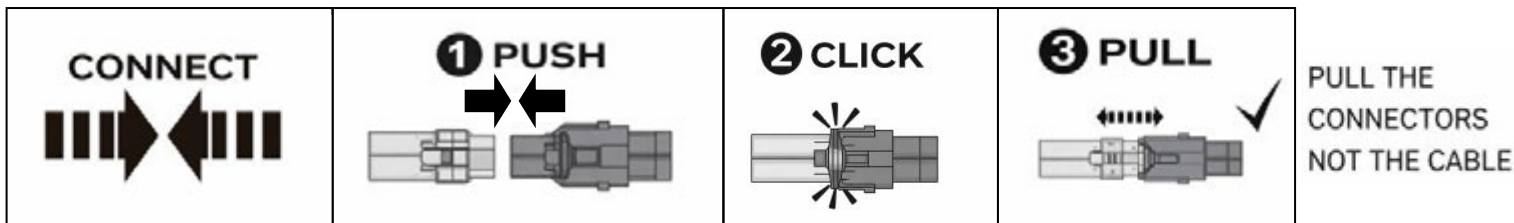
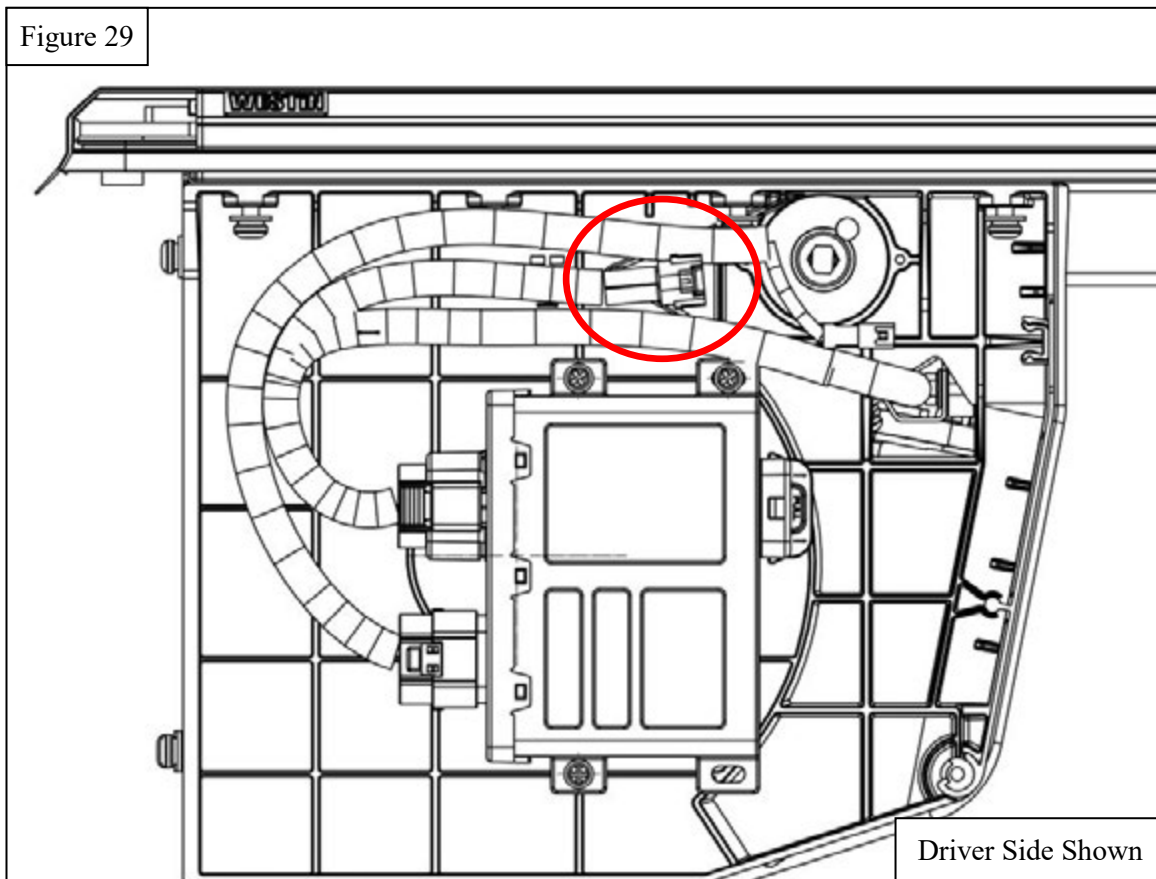

21. Once the Power Cable (**Item 13**) is routed out through the hole near the top driver side of the bed, from there, the harness will travel down the length of the vehicle frame, up into the engine bay, and to the vehicle battery on the passenger side. Using Nylon Ties (**Item 25**), secure the wire harness so it does not come into contact with moving parts or exhaust pipes. Keep the wire harness as high as possible along the frame to prevent damage while driving. Use the nylon ties to secure the wire harness along the frame. Leave about 1.5 ft. of the power harness loose in the bed. Remove the fuse from the fuse holder on the positive power harness connector and connect it to the main power harness. Do not connect the power harness to the vehicle battery at this time. See **Figures 30-35**.

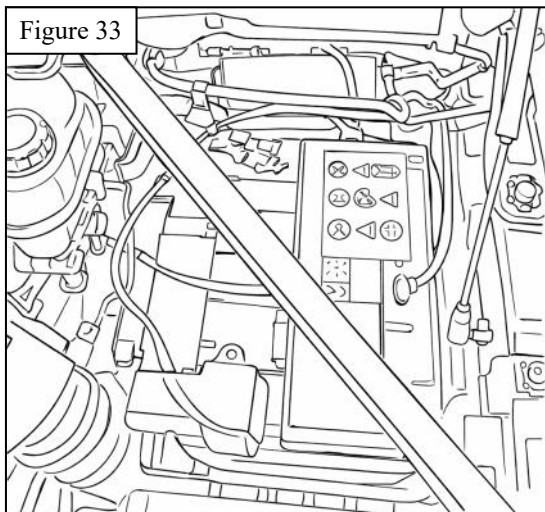
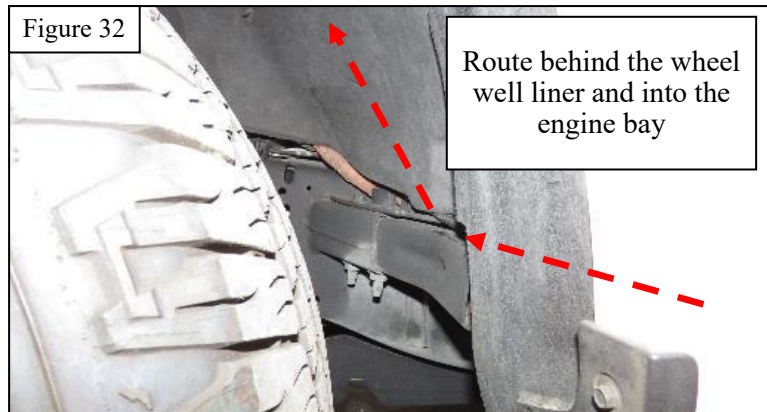
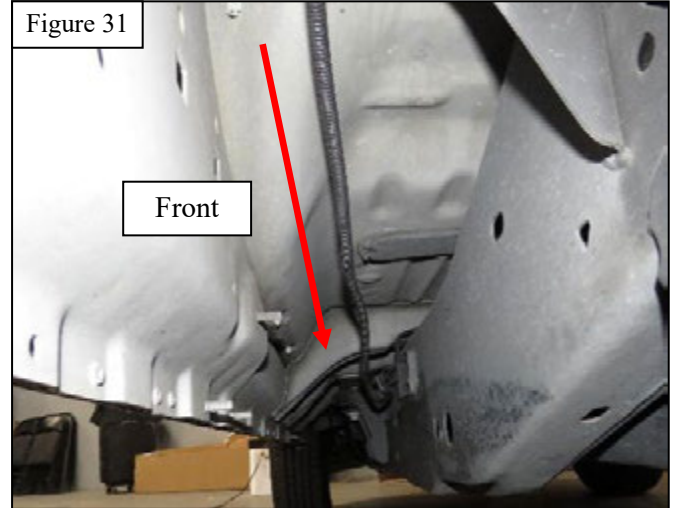
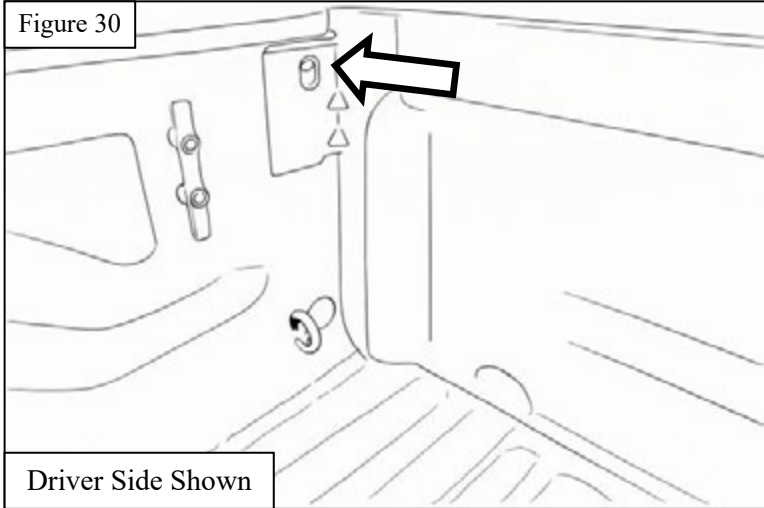

22. With assistance, carefully lift the tonneau cover assembly, and place it on top of the truck bed. Do not slide the tonneau cover along the bed as this will damage the foam seals. Leave the front of the tonneau cover about 1 ft from the front of the bed and connect the power harness to the connector on the ECU main harness. Carefully lift the tonneau cover and position it as far forward as possible without touching the front of the bed. Leave a small gap between the canister and the front of the bed. See **Figure 36**.

NOTE: Do not pinch the wire harness between the tonneau cover and the bed as it may get damaged.

Figure 36



HEAVY

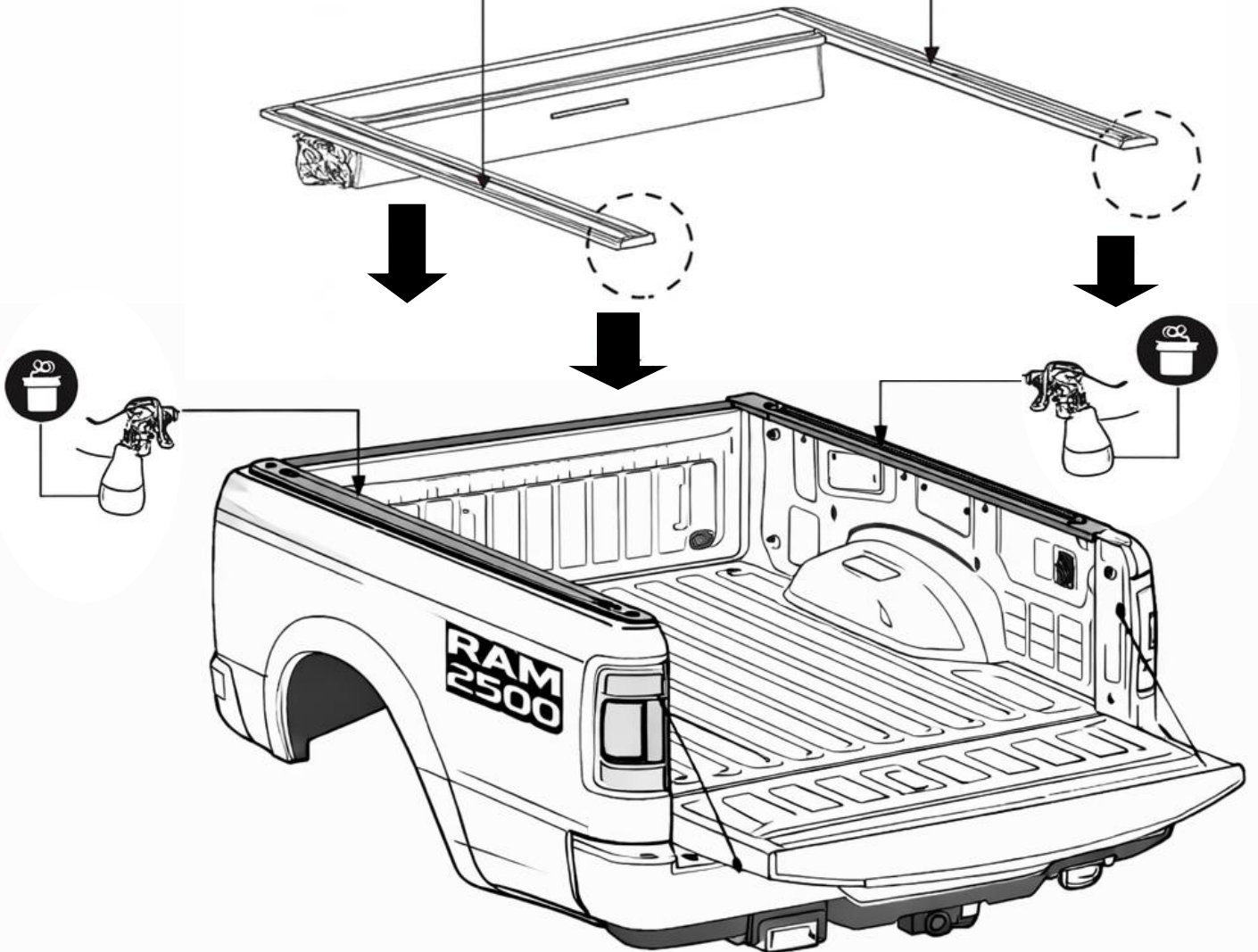
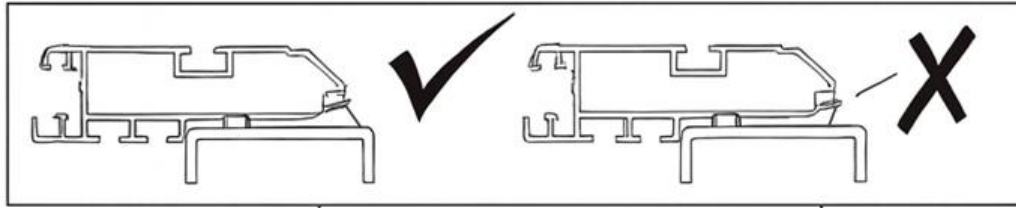

23. Starting on the Driver Side, insert 5 M6 T-Channel Nut Blocks (**Item 30**) through the channel on the bottom of the driver side rail and position them above the mounting points for the mounting brackets. See **Figure 37**.
24. Loosely attach the previously installed Driver Front Mounting Bracket to the T-channel nut block positioned above it using 1 M6 Short Torx Combo Bolt (**Item 29**).
25. Using a Center Mounting Bracket and a Center Spacer Nut Plate (**Items 8 and 10**) loosely fasten the two onto the lip of the bed wall using 2 M6 Long Torx Combo Bolts (**Item 28**), and 2 M6 Short Torx Combo Bolts (**Item 29**) to attach the two to the 2 T-channel nut blocks positioned above it. Make sure the bracket is positioned slightly behind the wheel well. Use **Figures 39 and 42** as references.
26. With a Rear Clamp Bracket (**Item 9**), attach it to the lip of the bed by loosely tightening the top bolt shown in **Figure 43** to slowly close the clamp, and using 2 M6 Short Torx Combo Bolts (**Item 29**) to attach the bracket to the 2 T-channel nut blocks positioned above it.
27. Repeat **Steps 23-26** for the Passenger Side Rail and brackets (**Items 7-10**).

NOTE: Leave all mounting bracket hardware loose.

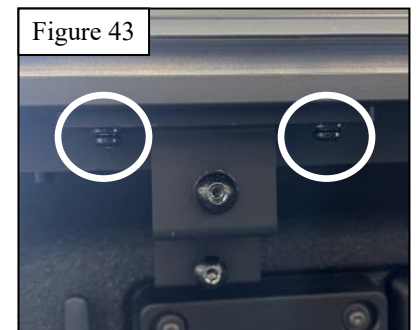
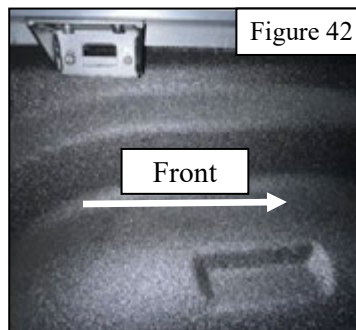
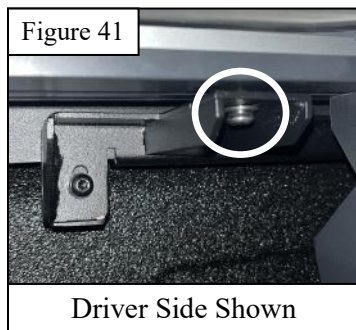
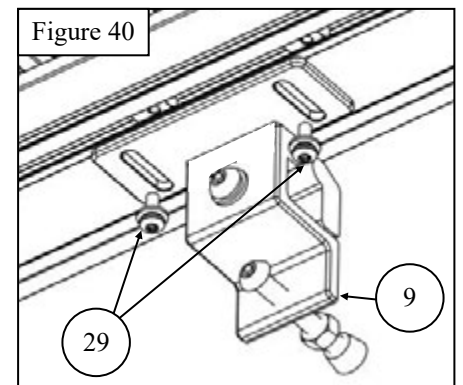
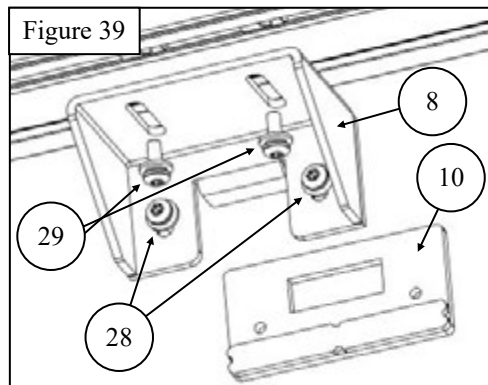
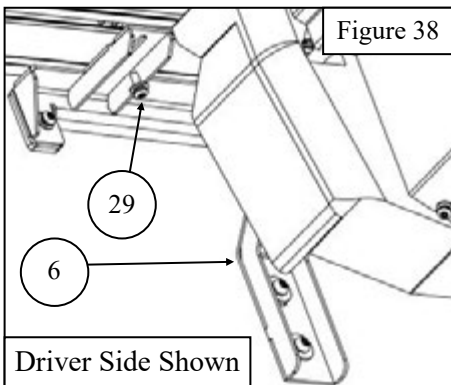
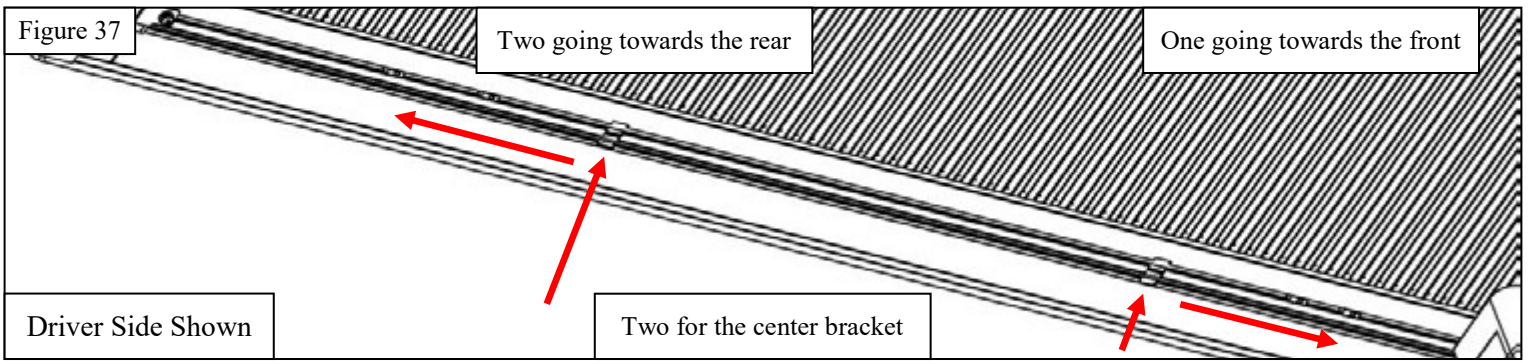

28. Align the side rails by using the Alignment Bar (**Item 5**). Insert the bar into the channel on the inner side of both side rails. Slide the alignment bar along the channels and check that the distance between the side rails is the same front-to-rear. Shift the ends of the side rails until the optimum position is achieved, then carefully push down on the end of the side rails and tighten the hardware for the rear mounting brackets. Use the alignment bar to double check the gap between the side rails and measure the distance between the outside of each side rail and the outer edge of the bed to ensure they are positioned centrally. This process may need to be repeated a few times until all measurements are optimal. After this has been completed, proceed to tighten the hardware for the front and center brackets, carefully pushing down on the side rails above each mounting bracket before tightening the hardware. As a final check to make sure the tonneau cover will operate smoothly, it can be manually moved through its full range of motion. Pull the motor clutch lever up to disengage the motor, then carefully pull on the tonneau cover. If it moves easily with no binding/ rough spots, proceed with the rest of the installation. If it is difficult to operate or has rough spots, the side rails will need further adjustment until the tonneau cover operates smoothly. See **Figures 41-43**.
29. Tighten all M5 hardware to 4-6 ft-lbs., M6 hardware to 7-11 ft-lbs., and M8 hardware to 17-26 ft-lbs.

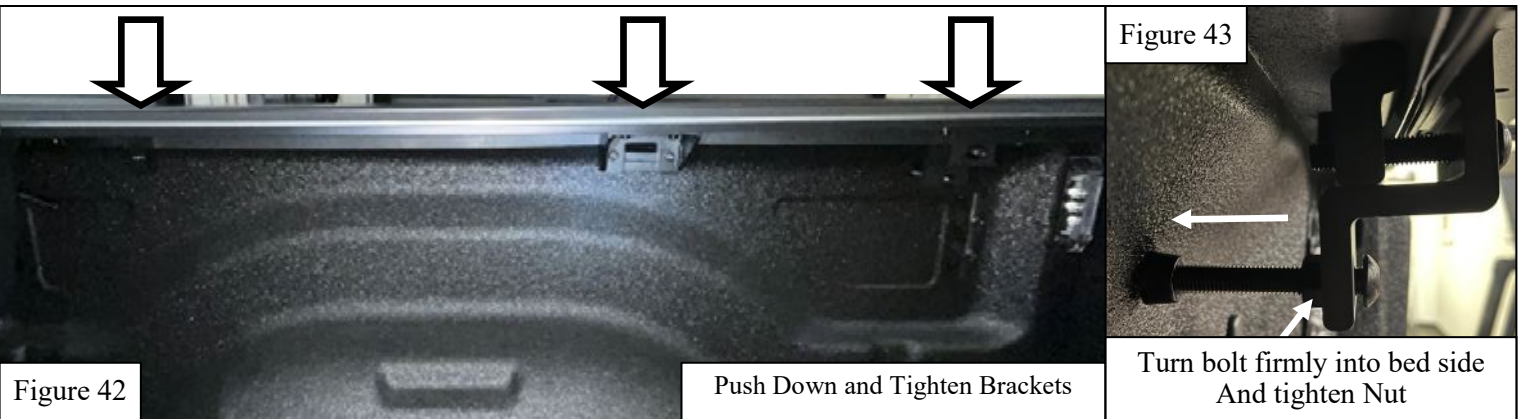
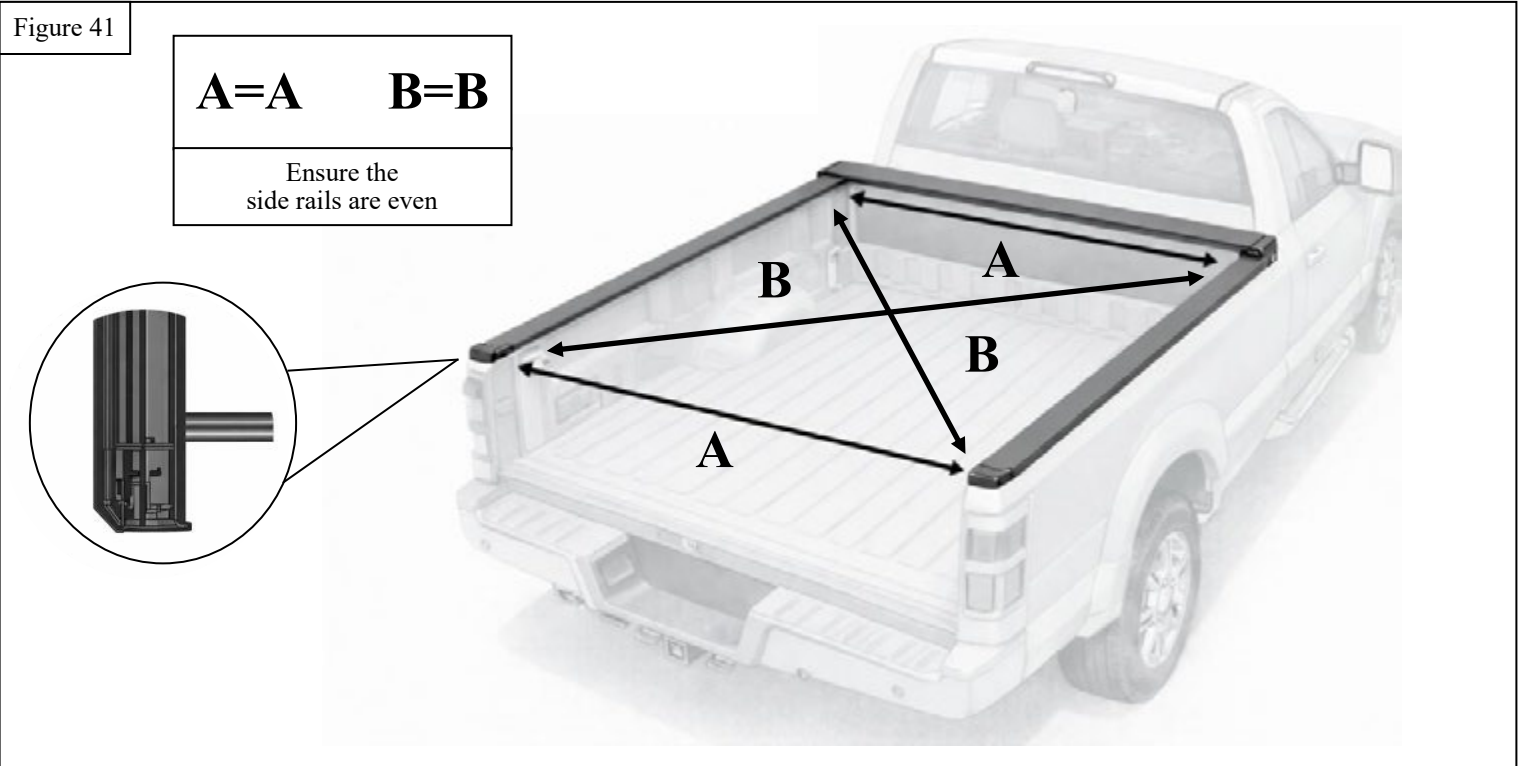

30. Starting on the Driver Side, install the Front Drain Tube Adapter (**Item 16**) onto the Front Drain Tube (**Item 17**) and tighten using the supplied Front Tube Clamp (**Item 20**). Place a Rubber Ring (**Item 19**) into the threaded mounting hole on the bottom of the canister then screw the drain tube adapter into the hole. See **Figures 44, 47, 48**.
31. Locate the Rubber Cap next to the front bed tie down hoop, cut around the cap to remove the bed liner that sits on top of it then remove the cap. Route the end of the Front Drain Tube through the hole. See **Figures 45-48**.
32. Slip the end of the Rear Drain Tube (**Item 18**) with the pre-installed Rear Tube Clamp (**Item 21**) onto the drain outlet at the end of the side rail. See **Figures 49 & 50**.
33. Route the bottom of the Rear Drain Tube through the hole at the base of the bed, next to the rear bed tie down hoop. Tighten the tube clamp until the drain tube is snug on the drain outlet. See **Figures 49 & 50**.
34. Repeat **Steps 30-33** for the Passenger Side.

NOTE: Do not over-tighten the front drain tube adapter as this may damage the plastic fittings, and do not over-tighten the tube clamps as this may cause damage to the drain outlet.

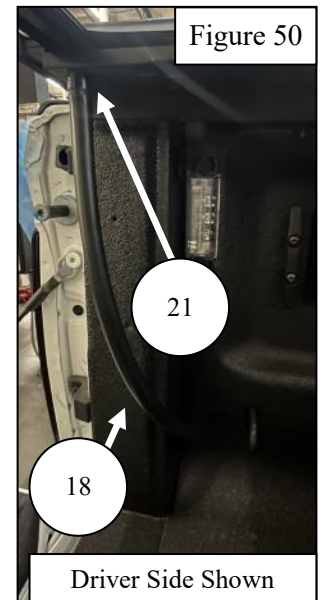
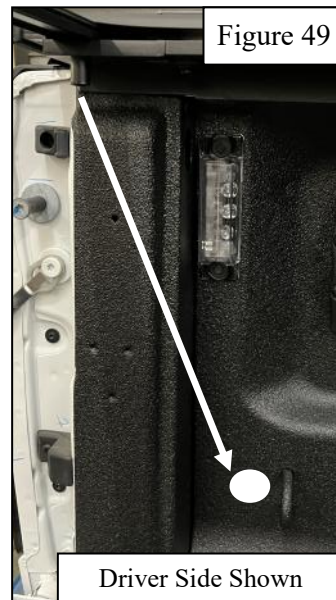
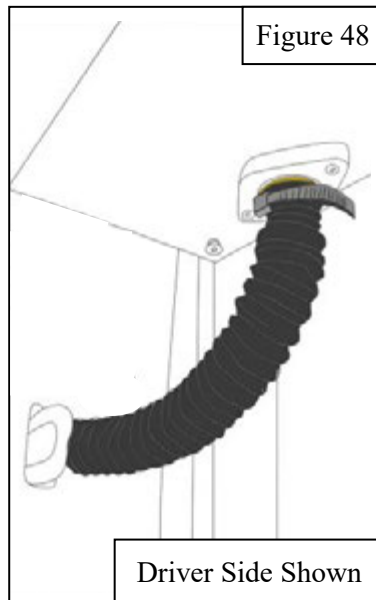
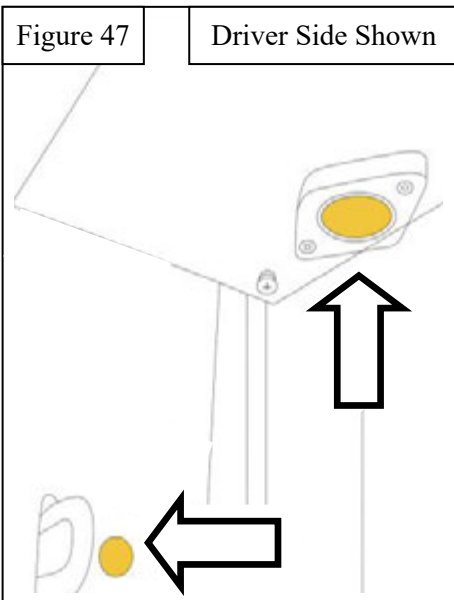
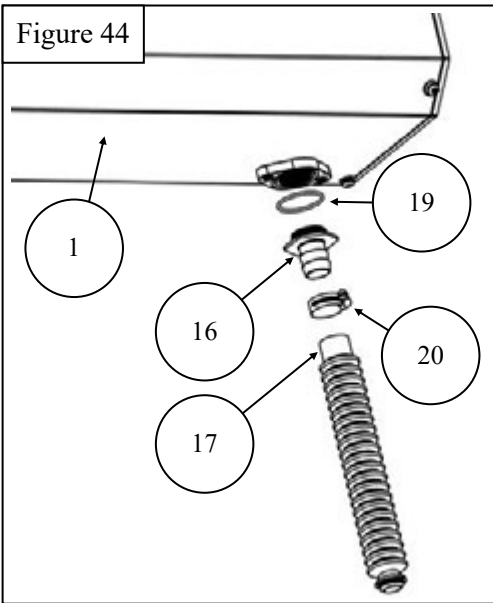

32. Ensure that the tonneau cover is engaged. If it is still in manual operation mode, push the motor clutch lever up, then pull on the end of the tonneau cover until the motor clicks, signifying that it is fully engaged.
33. Under the hood, locate the positive and negative terminals. Carefully connect the positive and negative ends of the Power Cable (**Item 13**). See **Figure 51**.
34. Once the tonneau cover power cable is securely attached to the vehicle battery, place the fuse back into the fuse holder and push the cap down until it is locked in place. Secure the wires in the engine bay so they will not get damaged by moving/hot components. See **Figure 51**.

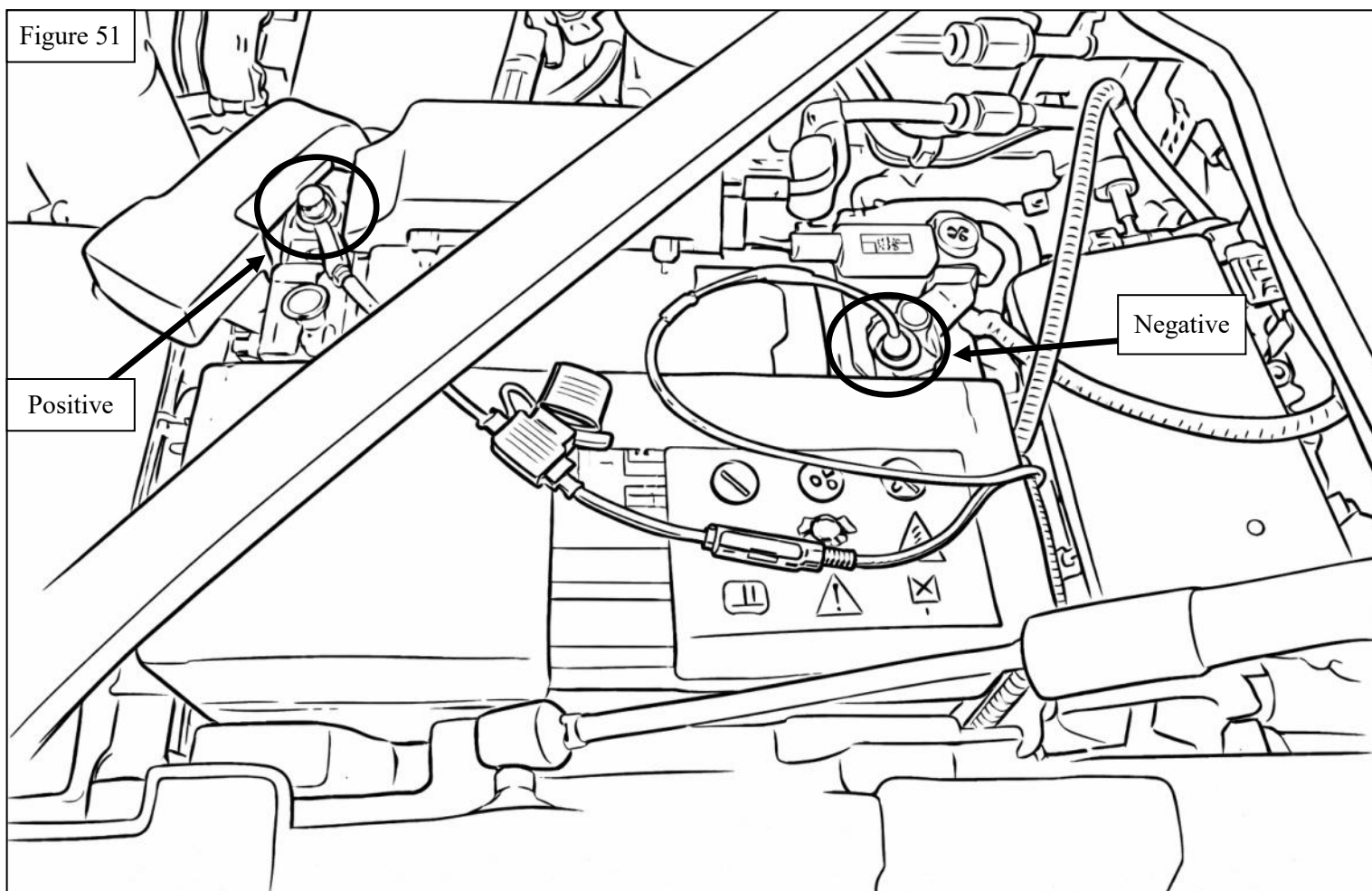

OPERATION OF THE TONNEAU COVER

Remote Key Fob

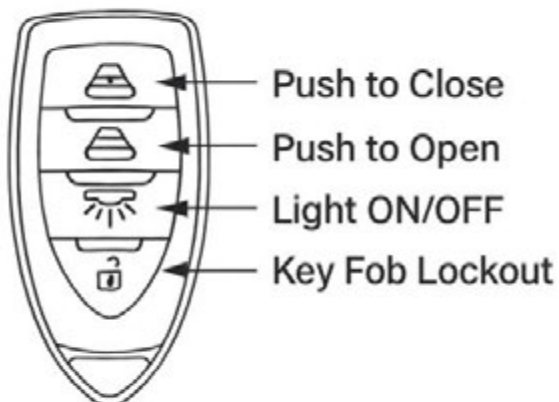

Key Fob Holder for convenient access



Prior to the first use of the tonneau cover, the self-calibration process must be performed:

- Press the Key Fob Lockout button to unlock the key fob, then press and hold the Light On/Off button for 3 seconds to activate the self-calibration function.
 - When it starts, the LED light will flash (2 long, 3 short) to confirm it has entered the self-calibration process. **Once the self-calibration has started, do not press any other buttons or interrupt the tonneau cover until the process has completed.**
 - The tonneau cover will open all the way to learn the fully open position
 - After 2 seconds, the tonneau cover will automatically close all the way to learn the fully closed position
 - When the self-calibration is complete, the LED light will flash (2 long, 3 short) times to confirm that the self-calibration process has been successfully completed

The self-calibration function should be used under the following conditions:

- The first time the tonneau cover is installed and connected to power
- Any time after the tonneau cover has been put into manual operation mode
- Any time it appears the tonneau cover is not fully opening or closing

Functions:

- Tonneau Cover Key Fob Lockout- when the key fob is locked, the buttons on the key fob will not operate the tonneau cover until it is unlocked.
 - Press key fob lock button- key fob use will be locked/unlocked
 - The key fob will automatically enter lockout mode if it is out of range of the antenna for more than 5 minutes
 - The first time the tonneau cover is connected to power or if it is disconnected from power, the key fob will enter its default “locked” status
 - The ECU will emit a sound to signify the status of the key fob each time the lock/unlock button is pressed
 - 1 beep- key fob is unlocked
 - 2 beeps- key fob is locked
- To open the tonneau cover- with the key fob in range, press the open button on the key fob (must be unlocked)
- To close the tonneau cover- with the key fob in range, press the close button on the key fob
- LED Light:
 - Auto Mode- when the tonneau cover opens, the light will automatically turn on and will stay on for 5 minutes. The light will automatically turn off once the tonneau cover is fully closed
 - Manual Mode- press the light button on the key fob to turn the light on/off. If the key fob is in its “lockout” mode, it will only turn the LED light off if it is already on
- Intermittent stopping- pressing the open/close button at any time the tonneau cover is operating will immediately stop it at its current position. Tonneau cover movement will resume by pressing either button (open or close) and will move in the direction corresponding to the button pressed (open or close) independent of the initial direction of travel prior to stopping
- Anti-Pinch Protection- if the tonneau cover detects an obstruction while it is operating, it will stop and back off about 4 inches. It will resume operating by pressing either the open or close button
- Switching to manual/electric modes- the tonneau cover can be switched between manual and electric operating modes by rotating the motor clutch handle up or down, as seen below:

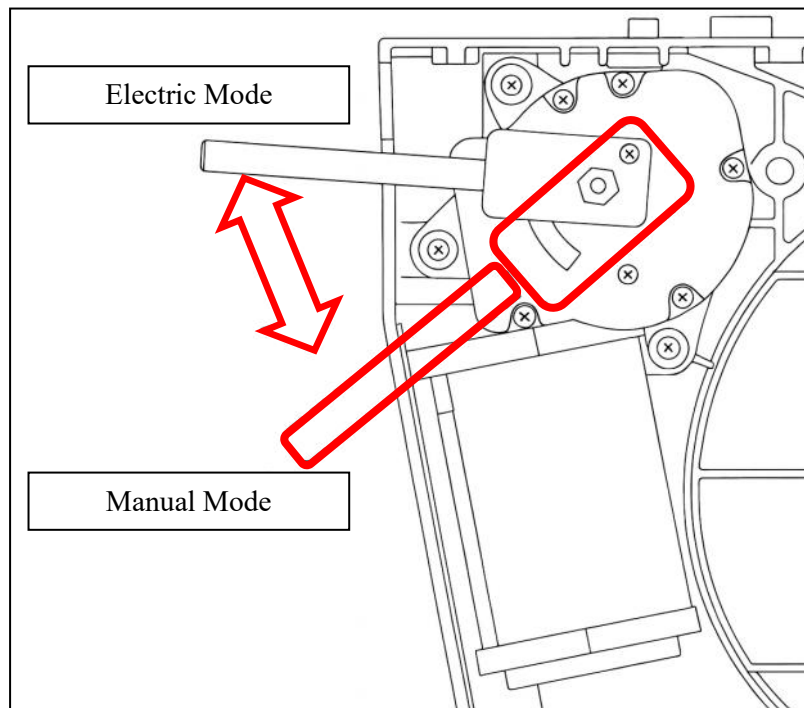

When switching from manual mode to electric mode, the self-calibration process (described previously) must be performed prior to normal operation of the tonneau cover

- System Status Indication (for repairing and troubleshooting ONLY): This function is used for troubleshooting when there's something wrong with the system and will indicate the status of the system through the flashing of the LED Light. There are two different signals of the LED Light, long flash and short flash, the error can be determined through the coding shown below:
 - Self-Calibration: start with long flash 2 times, and short flash 3 times; end with long flash 2 times, and short flash 3 times
 - Motor Position Sensor Error: long flash 3 times, and short flash 1 time
 - High Voltage: long flash 4 times, and short flash 2 times
 - Low Voltage: long flash 4 times, and short flash 3 times

FINAL NOTES

- Open and close the tonneau cover to ensure that it is operating without rubbing or binding
- Open and close the tailgate to check for proper movement
- On some models, a better fit with the tailgate may be obtained if the rear of the side rails are adjusted slightly up or down
- Recheck that all mounting hardware is tight.
- Check that the side rails are spaced evenly on the bed, and adjust accordingly

MAINTENANCE AND CARE

- Periodically clean the canister of dirt or debris that may have been collected inside
- Periodically check front and rear drain tubes and clean as needed
- A non-graphite dry lubricant may be sprayed onto the circular track inside the canister to maintain smooth operation of the tonneau cover
- Remove any snow or large debris from on top of the tonneau cover before opening
- Clean with mild soap and water only, do not use strong chemicals or cleaners. Do not wax the tonneau cover
- Periodically check that the tonneau cover is securely attached to the truck bed and that the mount brackets have not come loose. Frequent usage of the tonneau cover or vibrations from driving on rough roads may cause the tonneau cover to require adjustment
- Inspect the remote key fob and replace the battery as needed. The LED light on the key fob will change from green to red to indicate low voltage from the battery and that it should be replaced soon

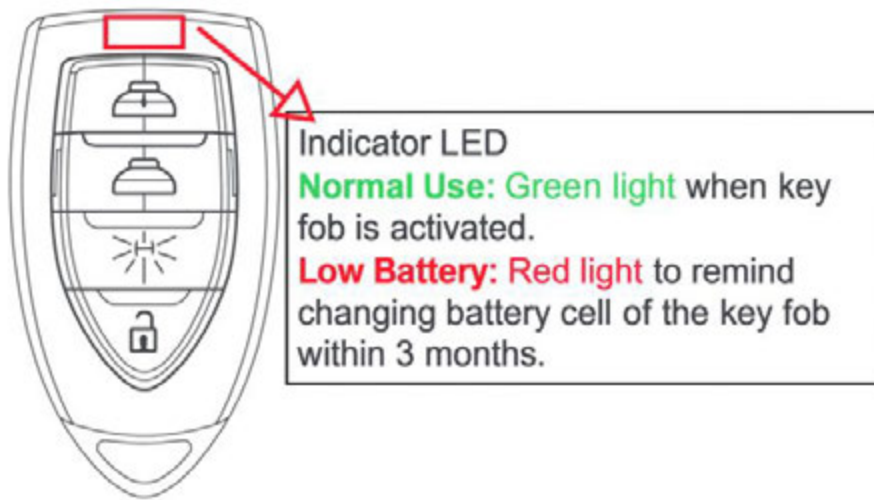

WARNING AND SAFETY INFORMATION

- Do not use the truck bed as a passenger compartment. In case of entrapment: Disengage the motor by removing the cover panel and lift the clutch release handle upward (front driver side of bed). Pull on the tonneau cover to retract.
- Do not store or transport volatile materials such as solvents, chemicals, or liquids as fumes may accumulate inside the bed. Do not allow solvents, chemicals, or oils to come into contact with the tonneau cover. If this happens, clean the tonneau cover immediately with a mild detergent and water solution.
- Do not stand/sit or rest heavy objects on the tonneau cover.
- Do not fill or store volatile liquid containers such as fuel cans while under the tonneau cover.
- Do not drive the vehicle with the motor clutch disengaged– A free-moving tonneau cover may move causing injury or damage to property while driving
- The tonneau cover is designed to be water and dust resistant in the majority of situations, in certain extreme environments a certain level of ingress is to be expected. Items that are of high value and are susceptible to water damage should be packaged accordingly. Condensation on the underside of the tonneau cover should be expected under certain conditions (cool days/nights).
- Do not subject the tonneau cover to excessive open/close forces. Excessive force may damage internal components, replacement of which may not be covered in your warranty
- While the tonneau cover has a built-in safety feature to prevent damage and injury, you must keep obstructions clear of cover during opening/closing
- To ensure your tonneau cover continues to operate in a trouble-free manner we recommend recalibrating the cover every 6 months. This interval may be reduced if you notice any irregularities when opening or closing the cover

INSTALLATION COMPLETE



CARE INSTRUCTIONS

- TEXTURE BLACK FINISHES SHOULD BE CLEANED WITH MILD SOAP AND WATER ONLY (DO NOT WAX).
- GLOSS BLACK FINISHES SHOULD BE CLEANED WITH MILD SOAP AND WATER.
- POLISHED STAINLESS PRODUCTS SHOULD BE CLEANED WITH MILD SOAP AND WATER. STAINLESS STEEL POLISH MAY BE USED TO REMOVE SMALL SCRATCHES.
- REGULAR WAXING IS RECOMMENDED FOR GLOSS BLACK AND STAINLESS STEEL PRODUCTS. DO NOT USE WAX THAT MAY CONTAIN ABRASIVES.



WARNING



Failure to follow these instructions could lead to death, personal injury, and / or property damage.

FASTENERS:

All Westin supplied fasteners must be utilized and installed in accordance with the installation instructions and apply torque to the specifications as defined. **DOUBLE CHECK ALL FASTENERS BEFORE INITIAL USE, AND PERIODICALLY IN THE FUTURE TO ENSURE PROPER FUNCTION AND SAFETY.**

DRILLING:

Most Westin products do not require drilling for installation. If drilling is defined as required, use caution when drilling a vehicle. **FAILURE TO REVIEW AN AREA TO BE DRILLED MAY RESULT IN PERSONAL INJURY AND/OR INJURY TO OTHERS AS WELL AS VEHICLE DAMAGE.**

EYE PROTECTION:

ALWAYS WEAR SAFETY GLASSES OR GOGGLES DURING THE INSTALLATION PROCESS TO AVOID PERSONAL INJURY.

MAXIMUM TOWING/CARRYING CAPACITY: (if applicable)

The Westin Receiver Hitches will have a visible tow rating label affixed directly on the product. User should never exceed the vehicle manufacturers maximum tow and weight rating regardless of the capacity of the hitch. **FAILURE TO FOLLOW THESE GUIDELINES WILL VOID THE WESTIN WARRANTY AND MAY RESULT IN PERSONAL INJURY AND/OR INJURY TO OTHERS AS WELL AS VEHICLE DAMAGE.**

FOR CALIFORNIA RESIDENTS ONLY-PROP 65 WARNING:

Some products may contain chemicals such as DEHP, which can cause cancer, birth defects or other reproductive harm. For more info go to www.p65warnings.ca.gov



Westin Automotive Products, Inc.
320 W. Covina Blvd
San Dimas, Ca. 91773