



AUTOMOTIVE PRODUCTS, INC.

INSTRUCTIONS—INSTRUCCIONES—CONSIGNES

APPLICATION: 2007-15 JEEP WRANGLER 4DR
APP PART # 21-3290,21-3295, 23-3290, 23-3295,23-73290
E SERIES/PLATINUM STEP BARS

ITEM	QUANTITY	DESCRIPTION	TOOLS NEEDED
1	2	STEP BARS	16MM SOCKET
2,3	2	FRONT MOUNTING BRACKETS (2) DRIVERS SIDE, (3) PASSENGER SIDE	13MM SOCKET
4,5	2	CENTER MOUNTING BRACKETS (4) DRIVERS SIDE, (5) PASSENGER SIDE	ALLEN KEY (INCLUDED)
6,7	2	REAR MOUNTING BRACKETS (6) DRIVERS SIDE, (7) PASSENGER SIDE	RATCHET
8	6	M10 NUT PLATES	TORQUE WRENCH
9	6	M10 HEX HEAD BOLTS	
10	6	M10 LOCK WASHERS	
11	6	M10 FLAT WASHERS	
12	6	M8 X 35MM HEX HEAD BOLTS	
13	12	M8 X 25MM HEX HEAD BOLTS	
14	18	M8 LOCK WASHERS	
15	12	M8 FLAT WASHERS	
16	6	M8 LARGE FLAT WASHERS	
17	12	M6 BUTTON HEAD BOLTS	
18	24	M6 FLAT WASHERS	
19	12	M6 NYLOK NUTS	

1. Remove contents from box, verify if all parts listed are present and free from damage. Carefully read and understand all instructions before attempting installation. **ANTI-SEIZE LUBRICANT MUST BE USED WITH ALL STAINLESS STEEL FASTENERS TO PREVENT THEM FROM GALLING.**
2. Start installation toward the front of the passenger side of the vehicle. Determine if the vehicle has an open floor panel or a threaded hole in the floor panel for the top tab on the Bracket, (Figures 1 - 2). Remove any insulation that may be covering the mounting locations.
3. Select the passenger side front Bracket. **VERY IMPORTANT:** The 6 Mounting Brackets look very similar. Use the instructions to properly identify the front, center and rear Brackets for either side of the vehicle. Each bracket has been designed for a specific location for proper installation.
4. Vehicles with open mounting location: Insert (1) M10 Nut Plate into the large square opening in the floor panel. Line up the threaded nut with the small hole in line with the tab on the Bracket, (Figure 1). Bolt the Bracket to the Nut Plate with (1) M10 Hex Bolt, (1) M10 Lock Washer and (1) M10 Flat Washer, (Figure 3A). Do not tighten hardware.
5. Line up the mounting plate on the Bracket with the (2) factory holes in the pinch weld. Bolt the Mounting Bracket to the back of the pinch weld using the included (2) M6 Button Head Allen Bolts, (2) M6 Flat Washers, (against pinch weld), (2) M6 Large Flat Washers, (inside against the bracket), and (2) M6 Nylon Lock Nuts, (Figure 3A). Leave loose at this time.

CARE INSTRUCTIONS

- REGULAR WAXING IS RECOMMENDED. DO NOT USE ANY TYPE OF POLISH OR WAX THAT MAY CONTAIN ABRASIVES
- STAINLESS STEEL PRODUCTS CAN BE CLEANED WITH MILD SOAP AND WATER. STAINLESS STEEL POLISH SHOULD BE USED TO POLISH SMALL SCRATCHES.
- GLOSS BLACK FINISHES SHOULD BE CLEANED WITH MILD SOAP AND WATER



Westin Automotive Products, Inc.
320 Covina Blvd
San Dimas, Ca. 91773

Thank You for choosing Westin products
For Additional installation assistance please call
Customer service (800) 793-7846
www.westinautomotive.com

6. Vehicles with factory threaded hole in floor panel: Bolt the tab on the Bracket to the threaded hole in the floor panel with (1) M8 x 35mm Hex Bolt, (1) M8 Lock Washer and (1) M8 Large Flat Washer, (Figures 2 & 3A). Do not tighten hardware.
7. Repeat Steps 2 – 6 for Center and Rear Mounting Bracket installation. Use the instructions to correctly identify the Brackets, (Figures 3B, 3C, 3D & 4).
8. Once all three Mounting Brackets are securely in position, place the passenger Sidebar onto the Mounting Brackets and secure it with the included (6) M8 x 25mm Hex Bolts, (6) M8 Lock Washers and (6) M8 Flat Washers, (Figure 5). NOTE: Mounting cradles on Brackets should be inline and pointing toward the rear of the vehicle for proper installation. Snug all hardware but do not tighten at this time.
9. Repeat steps 2-8 for drivers side installation.
10. Align and adjust step bars at this time then tighten all hardware at this time. Torque all M10 fasteners to 30-35 ft lbs, M8 to 25 ft lbs, and M6 to 15 ft lbs.

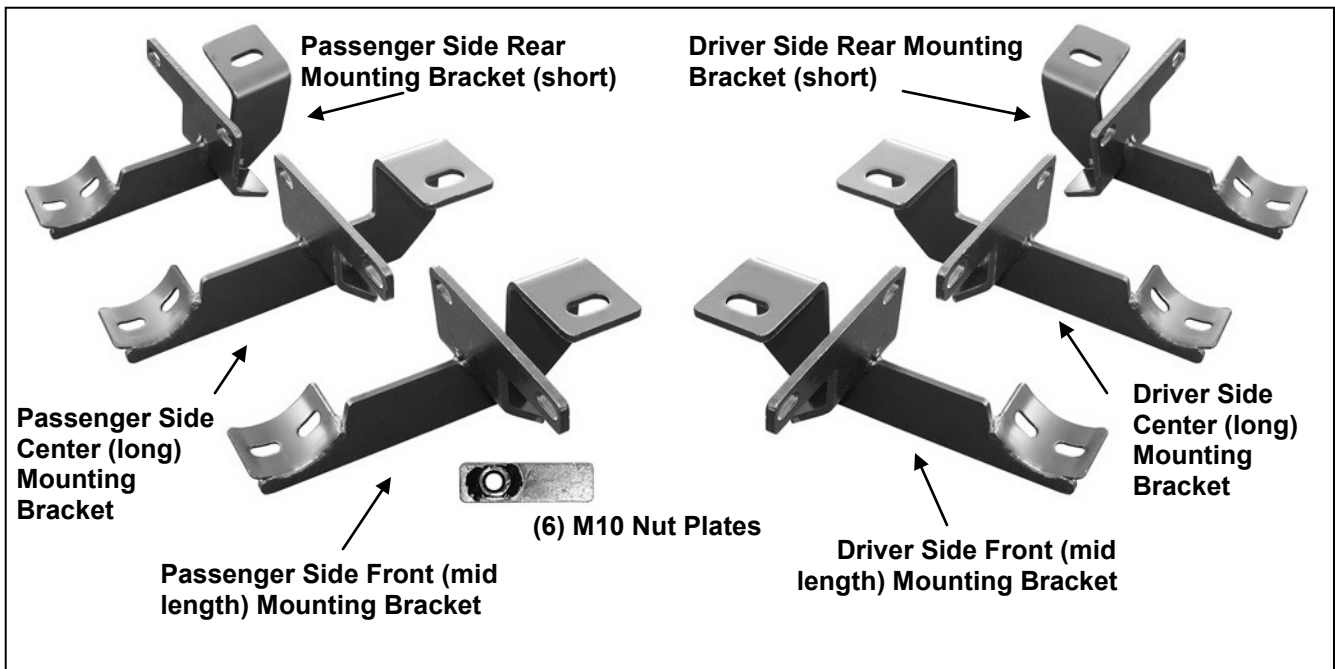

Westin Automotive Products, Inc.
 320 Covina Blvd
 San Dimas, Ca. 91773

Thank You for choosing Westin products
 For Additional installation assistance please call
 Customer service (800) 793-7846
www.westinautomotive.com

Insert M10 Nut Plate into opening and line up nut with mounting hole on Bracket

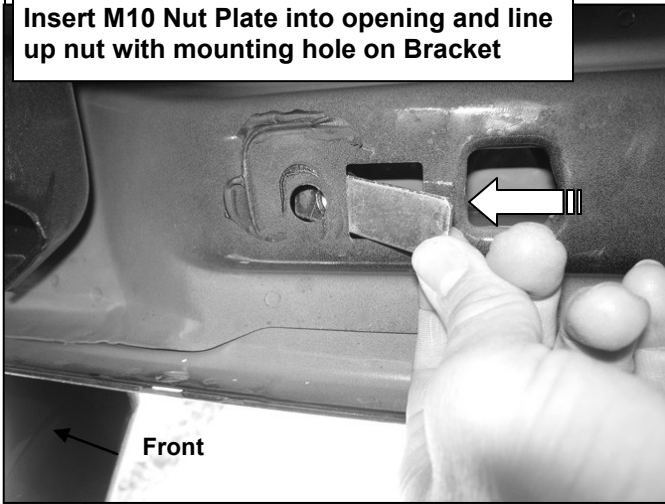

(Fig 1) Opening in floor frame channel



(Fig 2) M8 threaded hole in floor frame channel (passenger side-front pictured for example)



(Fig 3A) Passenger side Front Mounting Bracket installation pictured ("mid length" bracket)

Fig 3B

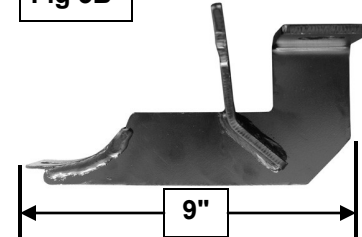

Passenger side "mid-length" front Bracket pictured

Fig 3C

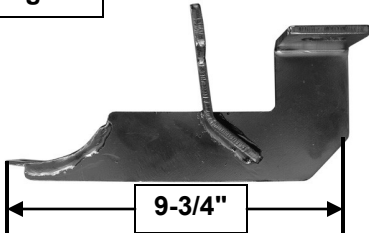

(Fig 3A) Passenger side "long" center Bracket pictured

Fig 3D



Passenger side "short" rear Bracket pictured

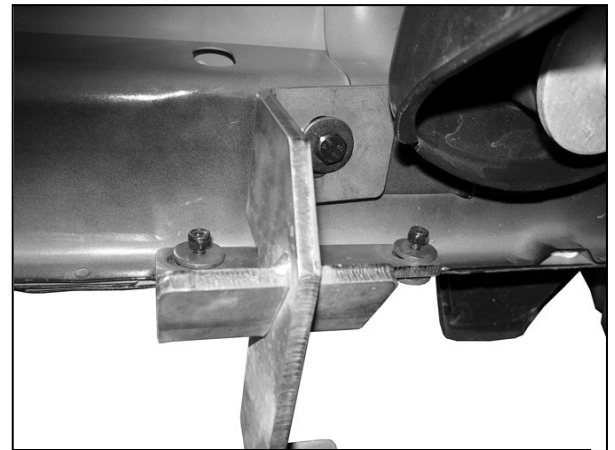

(Fig 4) Passenger side Rear Mounting Bracket installation pictured (short bracket)



Westin Automotive Products, Inc.
320 Covina Blvd
San Dimas, Ca. 91773

Thank You for choosing Westin products
For Additional installation assistance please call
Customer service (800) 793-7846
www.westinautomotive.com

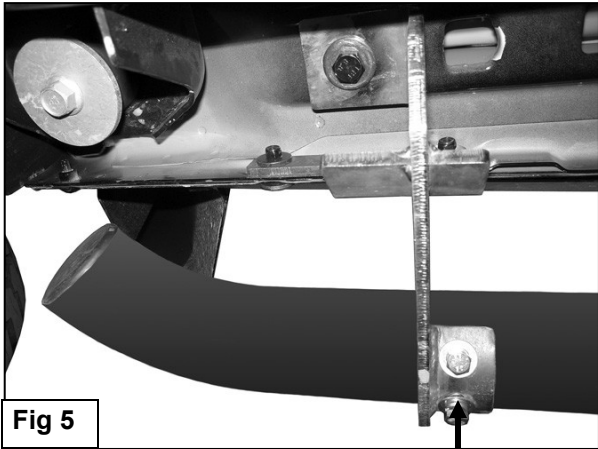

Fig 5

- (2) M8 x 25mm Hex Bolts**
- (2) M8 Lock Washers**
- (2) M8 Flat Washers**



Complete Installation



Westin Automotive Products, Inc.
320 Covina Blvd
San Dimas, Ca. 91773

Thank You for choosing Westin products
For Additional installation assistance please call
Customer service (800) 793-7846
www.westinautomotive.com