

INSTRUCTIONS—INSTRUCCIONES—CONSIGNES

APPLICATION: 2004-08 FORD F150 REGULAR CAB
APP PART # 21-2340, 21-2345
PLATINUM OVAL STEP BARS

ITEM	QUANTITY	DESCRIPTION	TOOLS NEEDED
1	2	STEP BARS	3/4" SOCKET AND RATCHET
2,3	2	FRONT MOUNTING BRACKETS (2) DRIVERS SIDE, (3) PASSENGER SIDE	18MM SOCKET AND RATCHET
4,5	2	REAR MOUNTING BRACKETS (4) DRIVERS SIDE, (5) PASSENGER SIDE	16MM SOCKET AND RATCHET
6	4	1/2" HEX HEAD BOLTS	13MM SOCKET AND RATCHET
7	4	1/2" FLAT WASHERS	TORQUE WRENCH
8	4	1/2" LOCK WASHERS	
9	2	M12 BOLT PLATES	
10	2	M12 DOUBLE BOLT PLATES	
11	4	11MM PLASTIC RETAINER	
12	4	M10 NUT CLIPS	
13	6	M12 FLAT WASHERS	
14	6	M12 LOCK WASHERS	
15	6	M12 HEX NUTS	
16	4	M10 HEX HEAD BOLTS	
17	4	M10 FLAT WASHERS	
18	4	M10 LOCK WASHERS	
19	8	M8 HEX HEAD BOLTS	
20	16	M8 FLAT WASHERS	
21	8	M8 LOCK WASHERS	
22	8	M8 HEX NUTS	

1. Remove contents from box, verify if all parts listed are present and free from damage. Carefully read and understand all instructions before attempting installation.
2. Starting at the passenger side-front of the vehicle, locate the round and rectangular openings in the inner body panel. NOTE: Mounting holes may be covered with rubber plugs and/or sealing tape. Remove to uncover mounting locations. Insert (2) M10 Clip Nuts (with the nut portion to the inside) into the rectangular opening and line up the threaded nut with the factory round holes, (Figure 1). Next, partially thread (1) 11mm Plastic Retainer onto (1) M12 Bolt Plate, (Figure 2), and insert the Bolt Plate into the large round hole. Once inserted, thread the Plastic Retainer onto the threaded end of the Bolt Plate until it is flush against the body panel. NOTE: When properly installed, the Plastic Retainer is designed to prevent the Bolt Plate from falling into the body cavity during Bracket installation.
3. Locate the driver side front Mounting Bracket. Attach the Mounting Bracket to the Bolt Plate with (1) M12 Flat Washer, (1) M12 Lock Washer and (1) M12 Hex Nut. Do not tighten hardware at this time. Line up the two holes in the Mounting Bracket with the previously installed Nut Clips and secure with (2) M10 Hex Bolts, (2) M10 Flat Washers and (2) M10 Lock Washers. Do not tighten hardware at this time. Next, line up the two holes in the front Mounting Bracket with the factory holes in the pinch weld. Attach the Mounting Bracket to the pinch weld using the included (2) M8 Hex Head Bolts, (2) M8 Lock Washers, (4) M8 Flat Washers and (2) M8 Hex Nuts, (Figure 3). NOTE: Insert the Bolt with the Flat Washer up, from the outside-in. Snug all hardware but do not tighten at this time.
4. Moving to the rear, locate the factory large round hole and smaller oval hole in the inner body panel. NOTE: Mounting holes may be covered with sealing tape, (Figure 4). Remove tape to uncover mounting locations. Select (1) M12 Double Bolt Plate and insert it into the larger round opening and out the smaller oval hole. Next, thread (1) 11mm Plastic Retainer onto the threaded end so that the retainer covers the smaller of

the two holes, (Figure 5). Thread the Retainer all of the way down to the sheet metal. NOTE: When properly installed, the Plastic Retainer is designed to prevent the Bolt Plate from falling into the body cavity during installation.

5. Select the passenger side Rear Mounting Bracket and attach it to the Double Bolt Plate with (2) M12 Flat Washers, (2) M12 Lock Washers and (2) M12 Hex Nuts, (Figure 6). Snug all hardware but do not tighten at this time.
6. Once the Mounting Brackets are partially mounted, carefully unpack and separate the driver and passenger Sidebars. Position the passenger Sidebar onto the Mounting Brackets using the included (2) 1/2" x 2" Hex Head Bolts, (2) 1/2" Lock Washers, and (2) 1/2" Flat Washers. Snug but do not tighten at this time.
7. Level and adjust side bar as needed then fully tighten all hardware at this time. Torque all 1/2" hardware to 50-55 ft lbs, M12 to 50 ft lbs, M10 to 35 ft lbs, and M8 to 25 ft lbs
8. Repeat steps 2-7 for drivers side.

CARE INSTRUCTIONS

- REGULAR WAXING IS RECOMMENDED. DO NOT USE ANY TYPE OF POLISH OR WAX THAT MAY CONTAIN ABRASIVES
- STAINLESS STEEL PRODUCTS CAN BE CLEANED WITH MILD SOAP AND WATER. STAINLESS STEEL POLISH SHOULD BE USED TO POLISH SMALL SCRATCHES.
- GLOSS BLACK FINISHES SHOULD BE CLEANED WITH MILD SOAP AND WATER

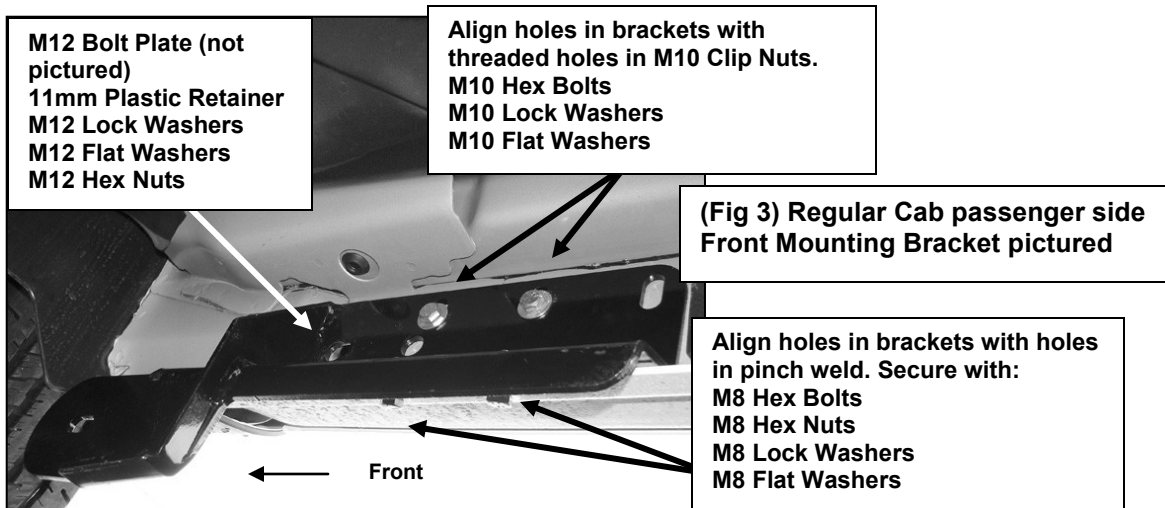
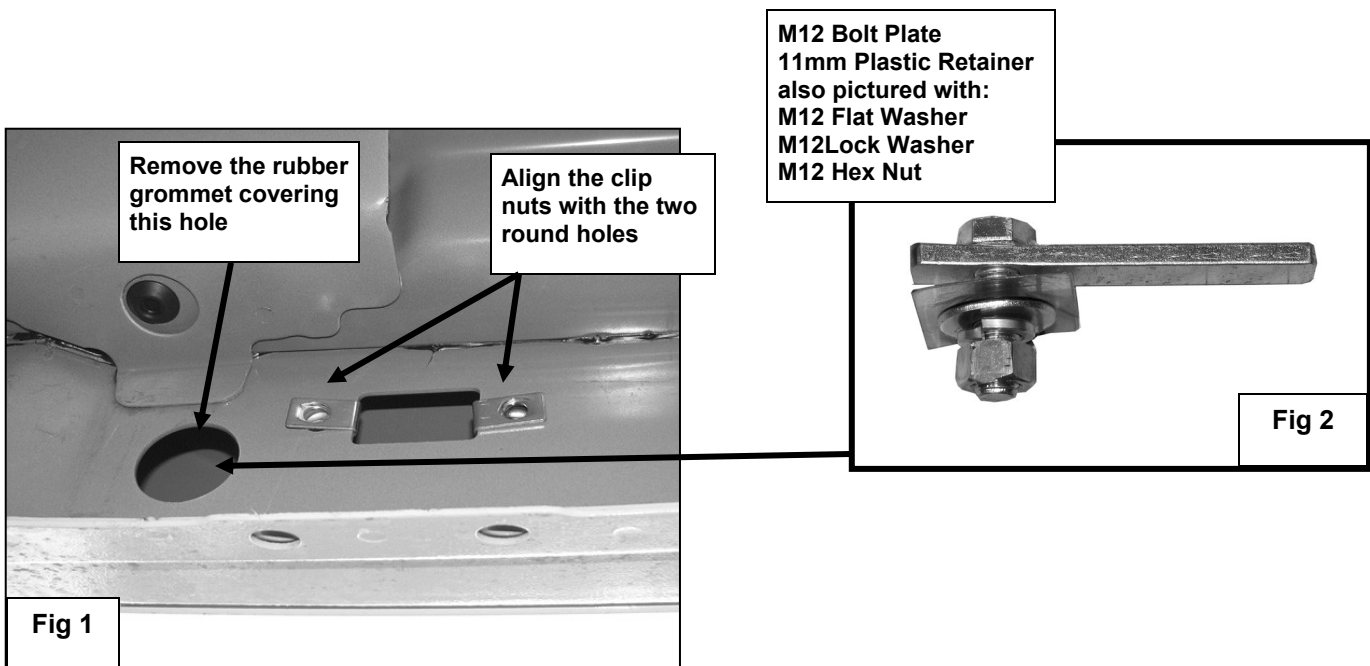

Westing Automotive Products, Inc.
5200 N. Irwindale Ave. Suite 220
Irwindale, Ca. 91706

Thank You for choosing Westin products
For Additional installation assistance please call
Customer service (800) 793-7846
www.westinautomotive.com

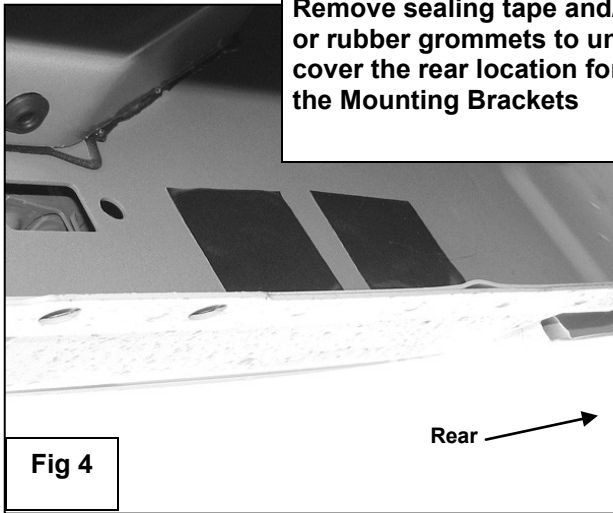

Remove sealing tape and/or rubber grommets to uncover the rear location for the Mounting Brackets

Fig 4



Fig 5 Regular Cab passenger side rear mounting location pictured

Insert the M12 Double Bolt Plate into the large round hole and back out the oval hole. Thread the 11mm Plastic Retainer onto the threaded end and cover the oval hole. Secure the Rear Mounting Bracket to the Bolt Plate with:
 2) M12 Flat Washers
 2) M12 Lock Washers
 2) M12 Hex Nuts

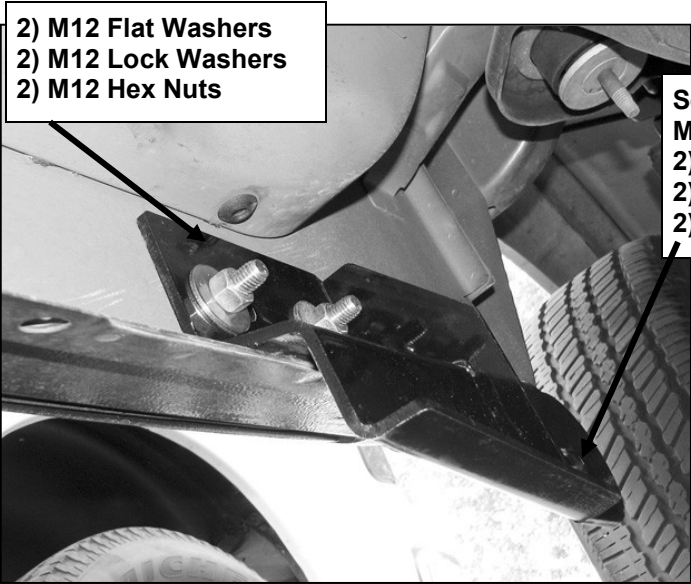

2) M12 Flat Washers
 2) M12 Lock Washers
 2) M12 Hex Nuts

Secure the Sidebar to the Mounting Brackets with:
 2) 1/2" x 2" Hex Bolts
 2) 1/2" Flat Washers
 2) 1/2" Lock Washers



Westing Automotive Products, Inc.
 5200 N. Irwindale Ave. Suite 220
 Irwindale, Ca. 91706

Thank You for choosing Westin products
 For Additional installation assistance please call
 Customer service (800) 793-7846
www.westinautomotive.com