



AUTOMOTIVE PRODUCTS, INC.

INSTRUCTIONS—INSTRUCCIONES—CONSIGNES

APPLICATION: 11-12 CHEVY/GMC SILVERADO/SIERRA 2500/3500 EXTENDED CAB DIESEL
11-12 CHEVY/GMC SILVERADO/SIERRA 2500/3500 CREW CAB DIESEL
APP PART # 20-3765, 20-3775, 20-3760, 20-3770
GEN-X STEP BARS

ITEM	QUANTITY	DESCRIPTION	TOOLS NEEDED
1	2	STEP BARS	ALLEN KEY (INCLUDED)
2	6	MOUNTING BRACKETS	13MM SOCKET
3	2	FRONT PASSENGER SIDE MOUNTING BRACKETS (UPPER)	RATCHET
4	2	FRONT PASSENGER SIDE MOUNTING BRACKET (LOWER)	TORQUE WRENCH
5	12	M8 HEX HEAD BOLTS	HAND DRILL
6	12	M8 FLAT WASHERS	3/8" DRILL BIT
7	12	M8 LOCK WASHERS	
8	16	M10 BUTTON HEAD BOLTS(STAINLESS STEEL)	
9	16	M10 TOOTHED LOCK WASHERS (STAINLESS STEEL)	
10	16	M10 FLAT WASHERS (STAINLESS STEEL)	
11	12	M8 NUT CLIPS	
12	6	M8 FLANGE BOLTS	
13	6	M8 TOOTHED LOCK WASHERS	

ANTI-SEIZE LUBRICANT MUST BE USED ON ALL STAINLESS STEEL FASTENERS TO PREVENT THREAD DAMAGE AND GALLING.

- Remove contents from box, verify if all parts listed are present and free from damage. Carefully read and understand all instructions before attempting installation.
- FOR 11-12 CREW CAB:** Starting from the drivers side of the vehicle locate the threaded hole located in the rocker panel towards the front of the vehicle. Take (1) mounting bracket and attach it to the threaded hole using (1) M8 hex head bolt, (1) M8 lock washer, and (1) M8 flat washer. Locate the existing hole in the pinch weld and place (1) M8 clip nut onto the hole, attach the mounting bracket to the pinch weld using (1) M8 flange bolt, and (1) M8 toothed lock washer (FIG. 1). Do not fully tighten at this time
- Move to the next threaded hole in the rocker panel and repeat step 2.
- Remove the rubber plug from the bigger hole to access the smaller OD hole, and insert (1) M8 nut clip over the hole, attach (1) mounting bracket to the previously installed nut clip using (1) M8 hex head bolt, (1) M8 lock washer, and (1) M8 flat washer. Locate the existing hole in the pinch weld and place (1) M8 clip nut onto the hole, attach the mounting bracket to the pinch weld using (1) M8 flange bolt, and (1) M8 toothed lock washer (FIG. 2& 3). Do not fully tighten at this time
- Move to the circular hole located at the rear of the vehicle and repeat step 4.
- Move to the passenger side and locate the factory hole in the pinch weld, align the center mounting point of the lower front passenger side mounting bracket with this hole (FIG. 4). Mark the outer two holes on the lower bracket on the pinch weld and drill two 3/8" holes in the pinch weld (FIG. 5). Take the upper front passenger side mounting bracket, and the lower front passenger side mounting bracket and attach them to the pinch weld using (3) M8 hex head bolts, (3) M8 lock washers, and (3) M8 flat washers (FIG. 6). Repeat this step for the next mounting bracket.
- Repeat step 4 for the next two mounting brackets
- Take the drivers side step bar and place it on the mounting cradles attach the step bar using (8) M10 button head bolts, (8) M10 toothed lock washers, and (8) M10 flat washers (FIG. 7). Do not fully tighten at this time. Repeat this step for the passenger side step bar.
- Align and adjust step bars as needed then fully tighten all hardware at this time. Torque M10 hardware to 30-35 ft lbs, and M8 hardware to 25 ft lbs.
- FOR 11-12 EXTENDED CAB:** Starting at the drivers side of the vehicle locate the existing circular hole in the rocker panel towards the front of the vehicle. Remove the rubber plug from the bigger hole to access the smaller OD hole and insert (1) M8 nut clip over the hole, attach (1) mounting bracket to the previously installed nut clip using (1) M8 hex head bolt, (1) M8 lock washer, and (1) M8 flat washer. Locate the existing hole in the pinch weld and place (1) M8 clip



10/17/12

Westin Automotive Products, Inc.
320 Covina Blvd
San Dimas, Ca. 91773

P.N.: 75-0228-RevB ECO #: W12-0109

PG-1

Thank You for choosing Westin products
For Additional installation assistance please call
Customer service (800) 793-7846
www.westinautomotive.com

nut onto the hole, attach the mounting bracket to the pinch weld using (1) M8 flange bolt, and (1) M8 toothed lock washer (FIG. 2&3). Do not fully tighten at this time. Repeat step 1 for all of the mounting locations on the drivers side,.

2. Move to the passenger side and locate the factory hole in the pinch weld, align the center mounting point of the lower front passenger side mounting bracket with this hole (FIG. 4). Mark the outer two holes on the lower bracket on the pinch weld and drill two 3/8" holes in the pinch weld (FIG. 5). Take the upper front passenger side mounting bracket, and the lower front passenger side mounting bracket and attach them to the pinch weld using (3) M8 hex head bolts, (3) M8 lock washers, and (3) M8 flat washers (FIG. 6). Repeat this step for the next mounting bracket.
3. Repeat step 2 for the next two mounting brackets.
4. Take the drivers side step bar and place it on the mounting cradles attach the step bar using (8) M10 button head bolts, (8) M10 toothed lock washers, and (8) M10 flat washers (FIG. 7). Do not fully tighten at this time. Repeat this step for the passenger side step bar.
5. Align and adjust step bars as needed then fully tighten all hardware at this time. Torque M10 hardware to 30-35 ft lbs, and M8 hardware to 25 ft lbs.

CARE INSTRUCTIONS

- REGULAR WAXING IS RECOMMENDED. DO NOT USE ANY TYPE OF POLISH OR WAX THAT MAY CONTAIN ABRASIVES
- STAINLESS STEEL PRODUCTS CAN BE CLEANED WITH MILD SOAP AND WATER. STAINLESS STEEL POLISH SHOULD BE USED TO POLISH SMALL SCRATCHES.
- GLOSS BLACK FINISHES SHOULD BE CLEANED WITH MILD SOAP AND WATER

"PATENTED - U.S. Patent# 6588783 & 6874801"



Fig 1



Fig 2

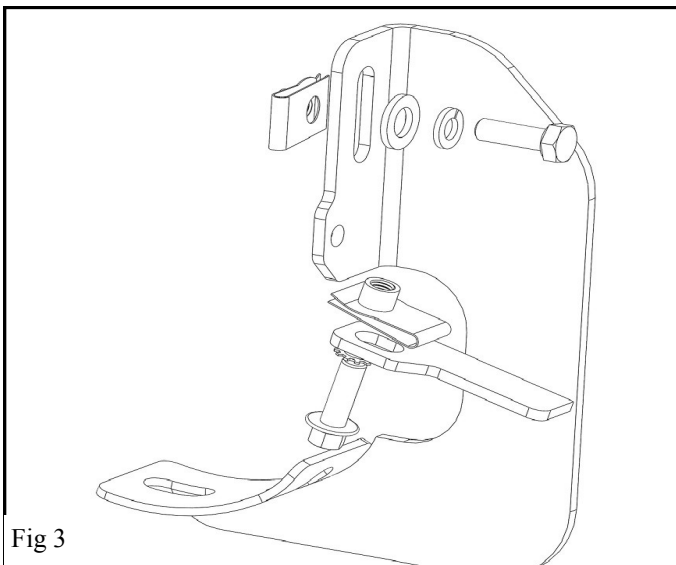

Fig 3

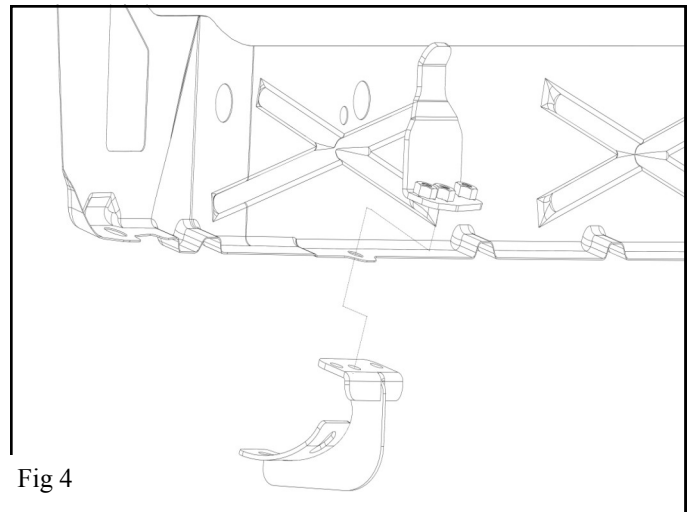

Fig 4

Westin
SIGNATURE OF QUALITY

Westin Automotive Products, Inc.
320 Covina Blvd
San Dimas, Ca. 91773

10/17/12

P.N.: 75-0228-RevB

ECO #: W12-0109

PG-2

Thank You for choosing Westin products
For Additional installation assistance please call
Customer service (800) 793-7846
www.westinautomotive.com

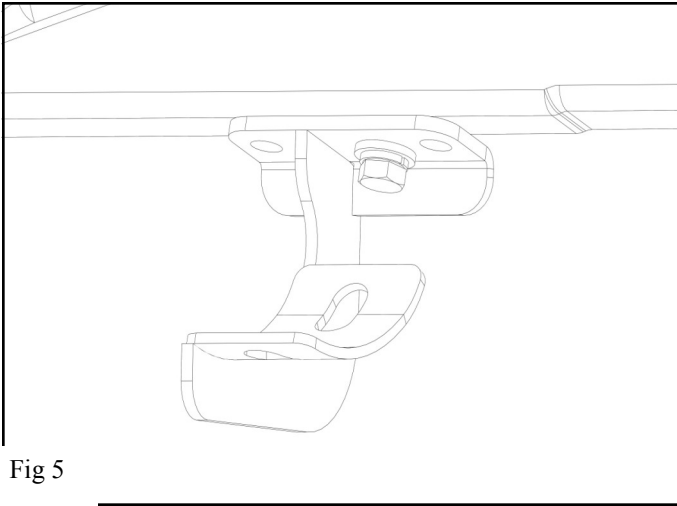

Fig 5

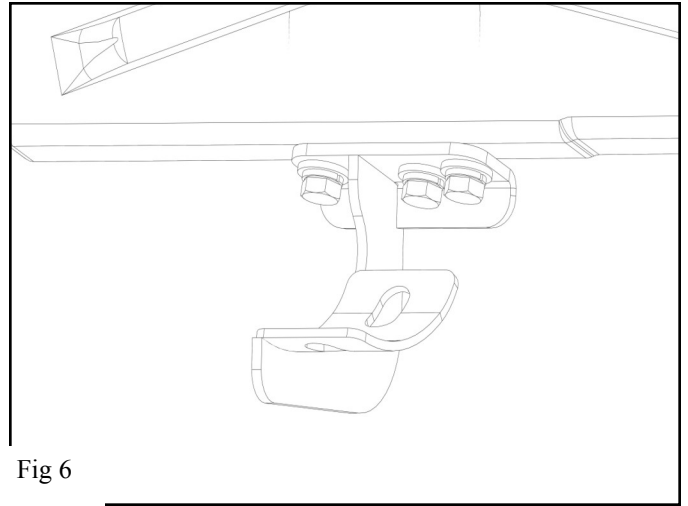

Fig 6



Fig 7



Westin Automotive Products, Inc.
320 Covina Blvd
San Dimas, Ca. 91773

10/17/12

P.N.: 75-0228-RevB

ECO #: W12-0109

PG-3

Thank You for choosing Westin products
For Additional installation assistance please call
Customer service (800) 793-7846
www.westinautomotive.com