

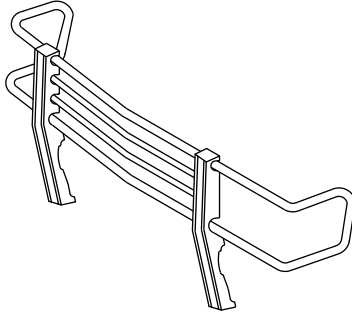

# INSTALLATION INSTRUCTIONS

APPLICATION: 1999-2000 FORD F-SERIES LIGHT DUTY 2WD  
2001 FORD SUPERCREW 2WD

## AUTOMOTIVE PRODUCTS, INC.

<p>CLASSIC GRILLE GUARD ASSEMBLY</p> <p><b>35-1410</b> <b>35-1420</b></p>		
QTY	PARTS KIT CONTENTS DESCRIPTION	TOOLS REQUIRED
1	UPRIGHT - PASSENGER SIDE	3/4" SOCKET
1	UPRIGHT - DRIVER SIDE	19MM SOCKET
1	WING - PASSENGER SIDE	RATCHET
1	WING - DRIVER SIDE	TORQUE WRENCH
1	CENTER SECTION	3/4" WRENCH
1	BRACKET - PASSENGER	SOCKET EXTENSION
1	BRACKET - DRIVER	DRILL
1	UPPER BRACKET - DRIVER	3/8" DRILL BIT
1	UPPER BRACKET - PASSENGER	UTILITY KNIFE
4	PROTECTIVE RUBBER STRIP	STRAIGHT EDGE
8	1/2-13 X 1.25" HEX HEAD BOLT	
14	1/2" SAE FLAT WASHER	
12	1/2" SPLIT LOCK WASHER	
4	12MM JAM NUT	
4	1/2-13 x 5.00" HEX HEAD BOLT	
4	1/2-13 HEX NUT	
4	SPACER PLATES	

Step 1. Remove the contents from the box and check for any damage. Verify all parts against the parts list.

Step 2. Read and understand instructions completely before beginning installation.

Step 3. To assemble the grille guard, position the center section, See **Figure 1** for proper orientation. The bottom side of the center section is the longer end. Insert wings so that wing slots line up with center section holes. Attach uprights to grille guard center assembly using 1/2" x 1.25" Hex head bolts, flat washers, and lock washers at lower and upper center section holes. **Hand tighten.** Place Protective Rubber Strips on uprights where contact to vehicle occurs.

**Note:** When Grille Guard is positioned against vehicle, the outer wing profiles should match the vehicle head-lamp/turn lamp assembly. If not, reverse wings in center section side to side.

- Step 4. From inside of frame behind bumper, position bracket so that front of bracket protrudes between top of bumper and bottom of grille. (If necessary, push down on bumper cover plastic to slide bracket through.) Locate bumper bolt ends (front side of frame), then position bracket slots on bolt ends, over existing nuts. Hand tighten supplied 12mm jam nuts over bracket. Repeat step on opposite side. **Figure 2.**
- Step 5. To install bottom mounting brackets, small openings must be cut into the lower airdam. Place a straight edge ruler against bottom of frame, centered from side to side (should line up with existing weld seam). Place a mark, on each side of ruler, where ruler and lower air dam meet. (marks should be approximately 1 1/2" apart). Drill a 3/8" hole through lower airdam, at each mark, from the backside. Using a utility knife, trim the area between the holes. Repeat for opposite side. Figure 2.
- NOTE: Holes are approximations, some trimming may be necessary after brackets are installed.
- Step 6 Install bottom brackets using (2) 1/2"-13 x 5.00" Hex head bolts, (4) 1/2" Flat washers, (2) 1/2" Lock washers, (2) 1/2"-13 Hex nuts, and (2) Spacer plates. Leave loose. Figure 3. Repeat for opposite side. (Bottom brackets will go through openings in airdam.)
- Step 7. Place assembled Grille Guard against vehicle and align bracket with threaded inserts on uprights. Bolt Grille Guard to brackets using 1/2"-13 Hex head bolts, 1/2" Flat washers and 1/2" Lock washers. (No flat washers on upper brackets.) Leave loose.
- Step 8. Center and level Grille guard. Tighten and torque fasteners to:
- |                |           |
|----------------|-----------|
| 1/2" fasteners | 65 ft.lbs |
| 12mm nuts      | 60 ft.lbs |
| Frame bolts    | 45 ft.lbs |

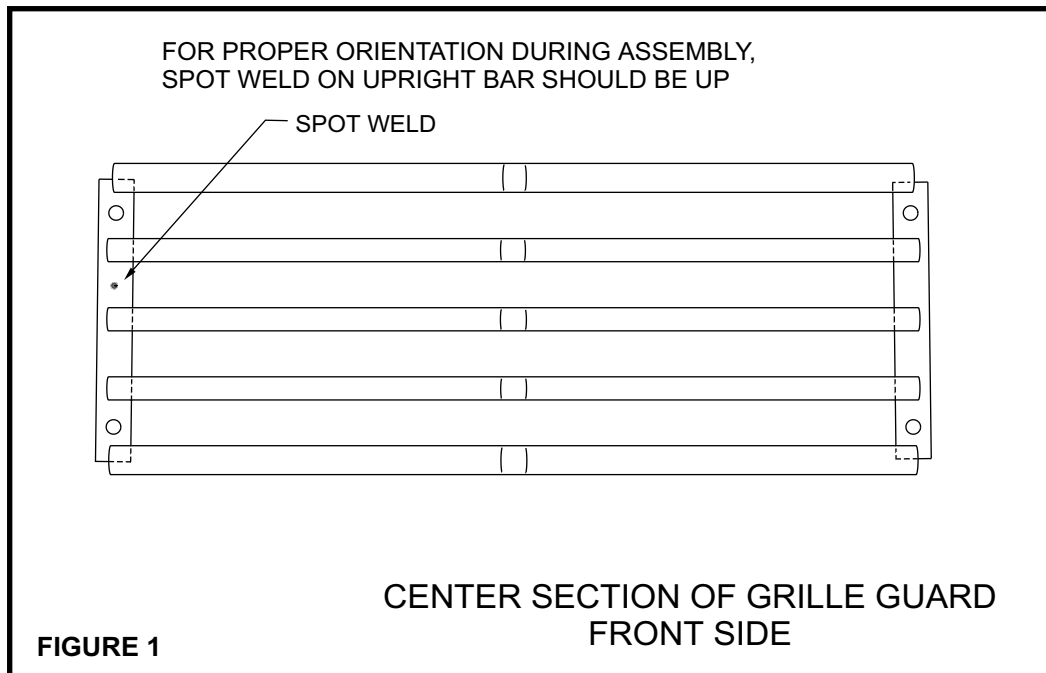

Finish protection - Westin products have a high quality finish that must be cared for like any other exposed finish on the vehicle. Protect the finish with a non-abrasive automotive wax (pure carnauba, for example) on a regular basis. The use of cleaner wax or any compound which contains an abrasive is detrimental, as the compounds scratch the finish and open it to corrosion.

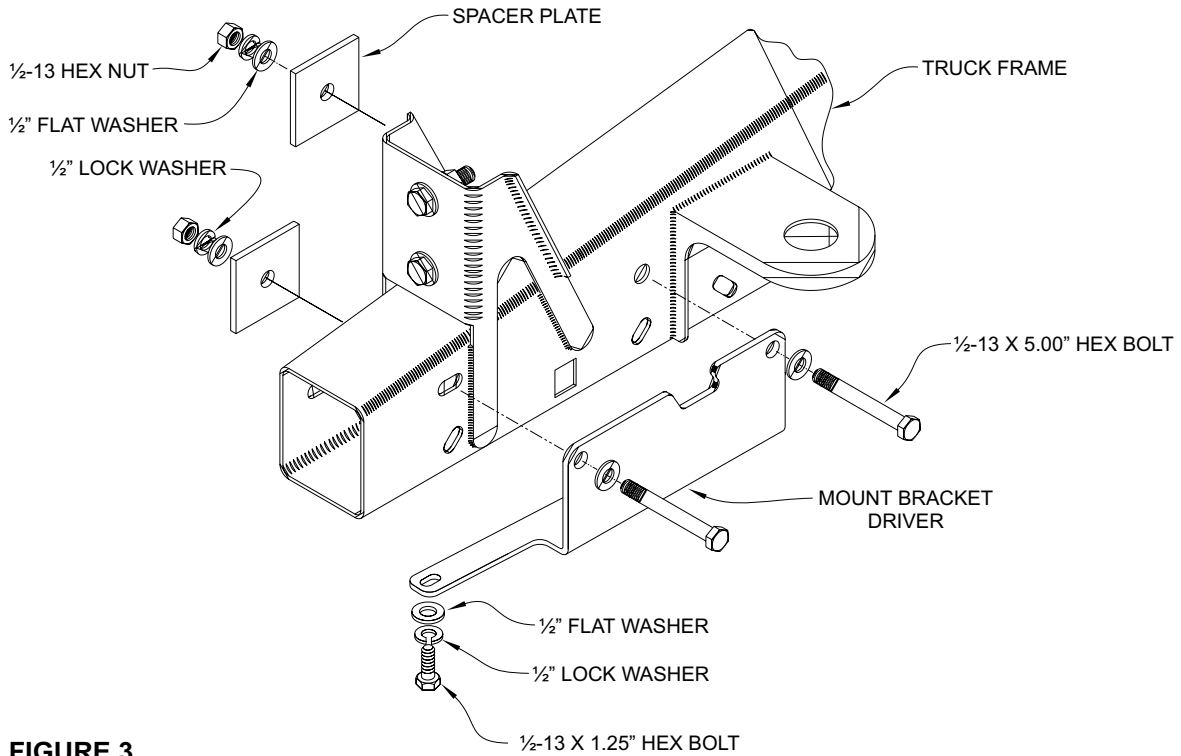
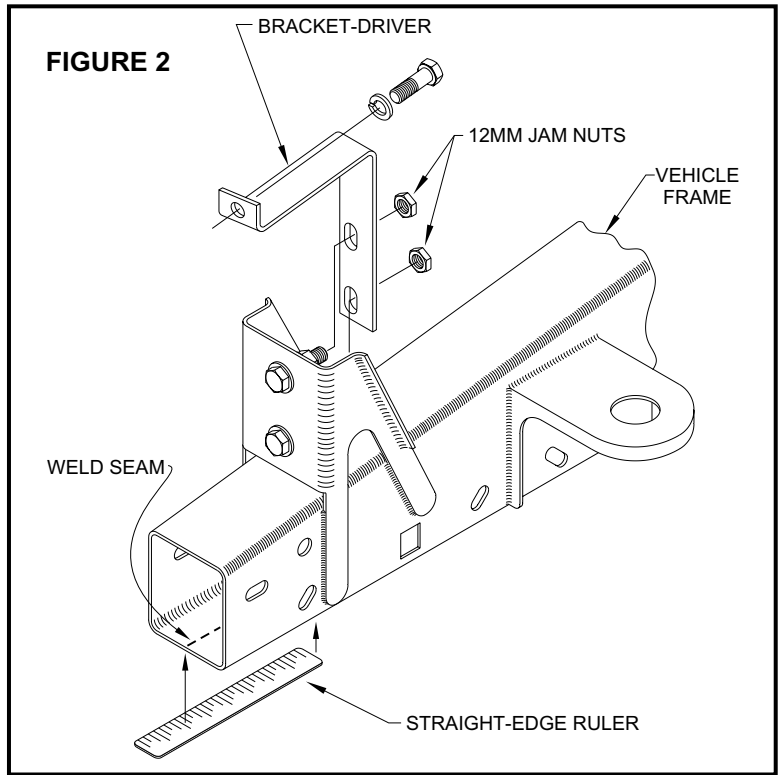
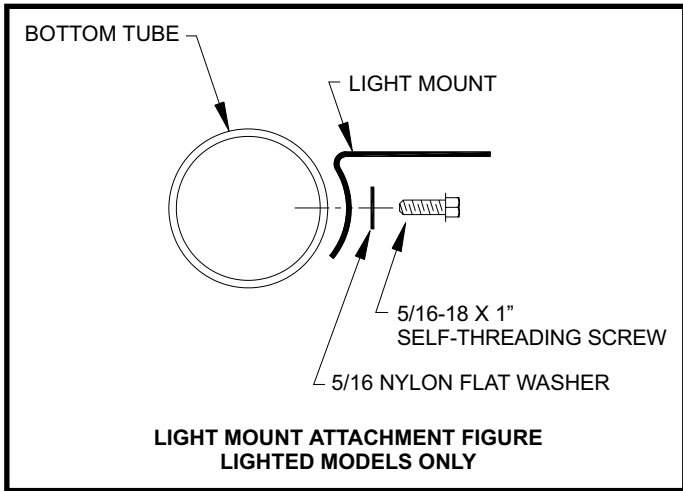

**DRIVER SIDE INSTALLATION SHOWN - PASSENGER SIDE OPPOSITE**