



INSTALLATION INSTRUCTIONS

APPLICATION: 1999-01 DODGE RAM SPORT 4X2 AND 4X4
 1994-01 DODGE RAM 4X4
 1997-01 DODGE RAM 4X2

AUTOMOTIVE PRODUCTS, INC.

SPORTSMAN
ASSEMBLY

40-0605

40-0615

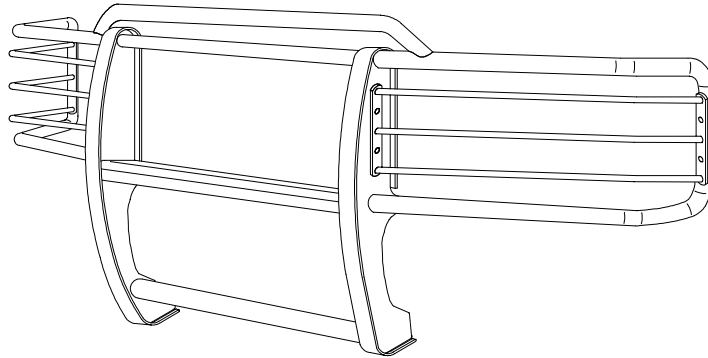

QTY	PARTS KIT CONTENTS DESCRIPTION	TOOLS REQUIRED
1	SPORTSMAN ASSEMBLY WITH LIGHT GUARDS	1/2" WRENCH
2	TOP BRACKET	9/16" WRENCH
2	BOTTOM BRACKET	9/16" SOCKET
1	SUPPORT BRACKET - DRIVER	3/4" SOCKET
1	SUPPORT BRACKET - PASSENGER	13MM SOCKET
2	MOUNTING TAB (DIESEL APPLICATIONS ONLY)	RATCHET
2	TOP CLAMP (DIESEL APPLICATIONS ONLY)	TORQUE WRENCH
2	BOLT PLATE	
2	M8- 1.25 X 25MM HEX HEAD BOLT	
2	3/8 -16 X 1.25" HEX HEAD BOLT	
2	3/8 -16 X 2.00" HEX HEAD BOLT	
6	3/8" FLAT WASHER	
2	3/8" LOCK WASHER	
4	3/8 -16 HEX NUT	
10	1/2 -13 X 1.25" HEX HEAD BOLT	
24	1/2" FLAT WASHER	
14	1/2" LOCK WASHER	
14	1/2 -13 HEX NUT	
2	5/16" LOCK WASHER	

- STEP 1. Remove the contents from the box and check for any damage. Verify all parts against the parts list.
Note: Some fasteners and brackets will be left over after installation.
- STEP 2. Read and understand instructions completely before beginning installation.
- STEP 3. Install driver side bottom bracket onto frame cross member using (1) bolt plate, (1) 1/2-13 x 1.25" hex bolt, (4) 1/2" flat washers, (3) 1/2" lock washers, and (3) 1/2-13 hex nuts. **See Figure 2 or 3.** Repeat for passenger side. Leave loose.
Note: When installing bolt plates into slot on frame, install the long end first. After bolt plate is in frame, rotate until bolts protrude through slot.
 1997 and older models without slots: Use the support brackets in place of the slot. **(Figure 2).** Bolt the support bracket to the bottom bracket and frame using (1) bolt plate, (1) 1/2-13 x 1.25" bolt, (4) 1/2" flat washers, (3) 1/2" lock washers, and (3) 1/2-13 hex nuts. Install (1) 1/2-13 x 1.25" hex bolt, (2) 1/2" flat washers, (1) 1/2" lock washer, and (1) 1/2-13 hex nut through single slot in support bracket. Leave loose.

- STEP 4. Skip this step on diesel models. With the hood open, remove the 8mm bolts from the A/C condenser support bracket. See Figure 1. Install top support bracket with (1) 8mm x 25mm hex bolt, (1) 3/8" flat washer, and (1) 5/16" lock washer. Repeat for other side. Leave loose.
- STEP 5. Place Sportsman assembly face down under front of vehicle. Line up rear slot in mount bracket with the rear most slot in the Sportsman assembly. Attach using (2) 1/2-13 x 1.25" hex bolts, (4) 1/2" flat washers, (2) 1/2" lock washers, and (2) 1/2-13 hex nuts. Leave loose.
- STEP 6. Rotate Sportsman assembly up until remaining slots are aligned. Install (4) 1/2-13 x 1.25" hex bolts, (8) 1/2" flat washers, (4) 1/2" lock washers, and (4) 1/2-13 hex nuts in remaining holes. Leave loose.
- Note: Diesel model owners proceed to step 8.
- STEP 7. Secure Top Support Bracket to the Sportsman assembly using (2) 3/8-16 x 1.25" hex bolts, (4) 3/8" flat washers, (2) 3/8" lock washers, and (2) 3/8-13 hex nuts. Leave loose.
- STEP 8. Center and level Sportsman with vehicle. torque all fasteners to:
- 1/2" fasteners = 65 FT. LBS
 3/8" fasteners = 30 FT. LBS
 8mm fasteners = 15 FT. LBS
- STEP 9. Secure top of Sportsman assembly with (2) Top Clamp, (2) Mount Tab, (2) 3/8-16 x 2.00" hex bolts, (4) 3/8" flat washers, (2) 3/8" lock washers, and (2) 3/8-16 hex nuts. Start the Top Support Clamp bolt on both sides and then draw unit in toward vehicle until it feels secure. Tighten nut against top clamp to secure.

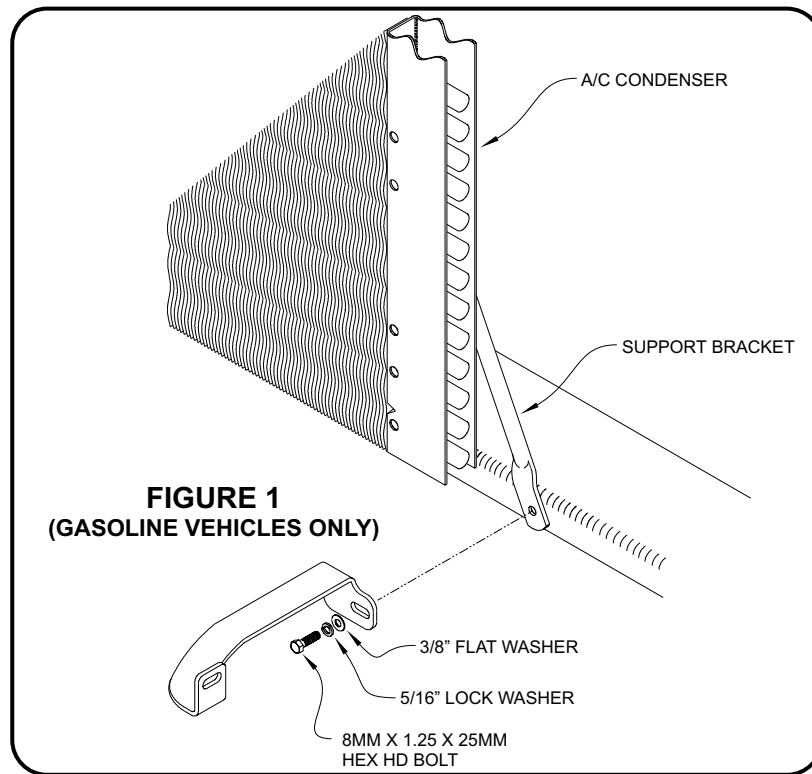

Finish protection - Westin products have a high quality finish that must be cared for like any other exposed finish on the vehicle. Protect the finish with a non-abrasive automotive wax (pure carnauba, for example) on a regular basis. The use of cleaner wax or any compound which contains an abrasive is detrimental, as the compound scratches the finish and opens it to corrosion.

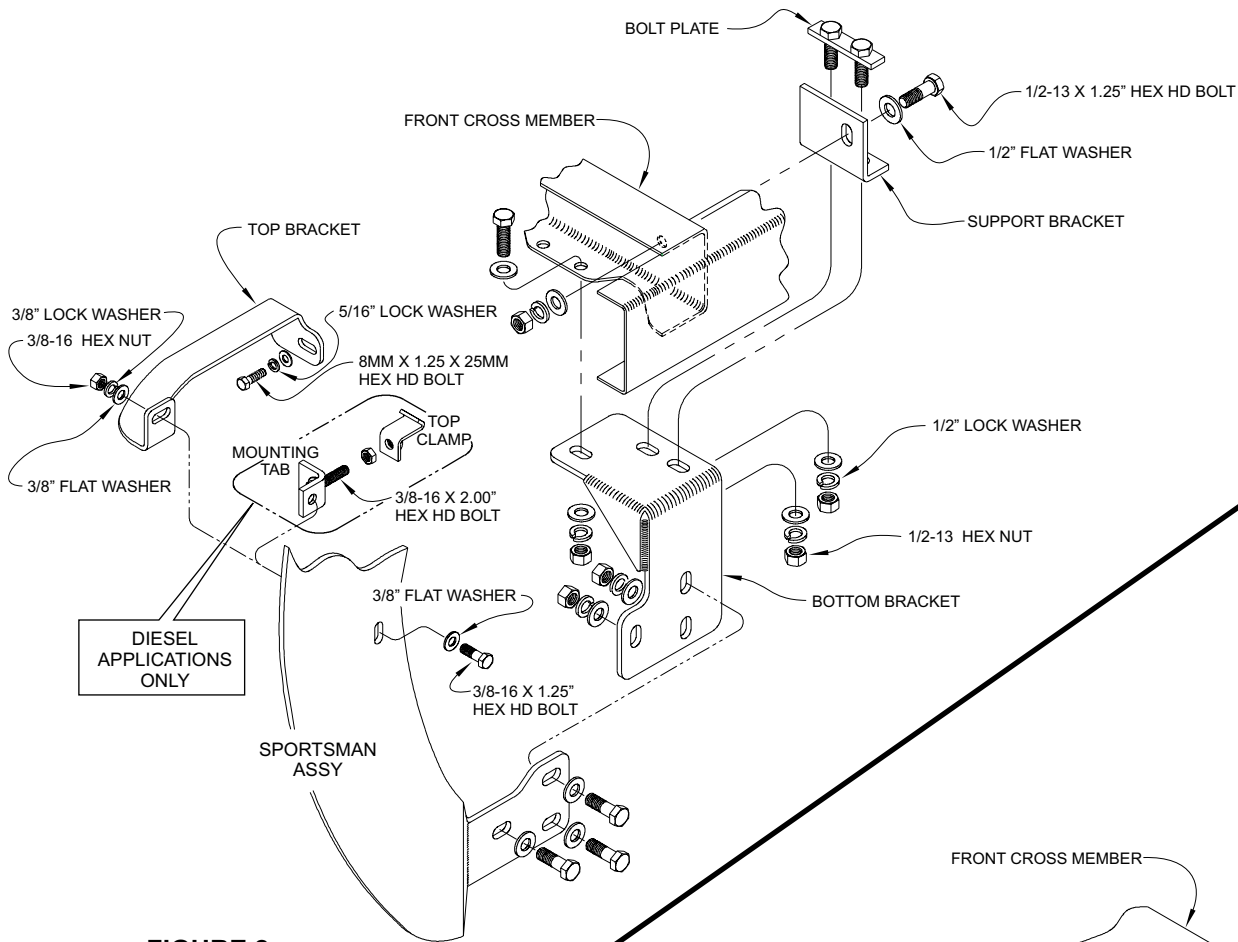

FIGURE 2
(1997 AND OLDER VEHICLES)

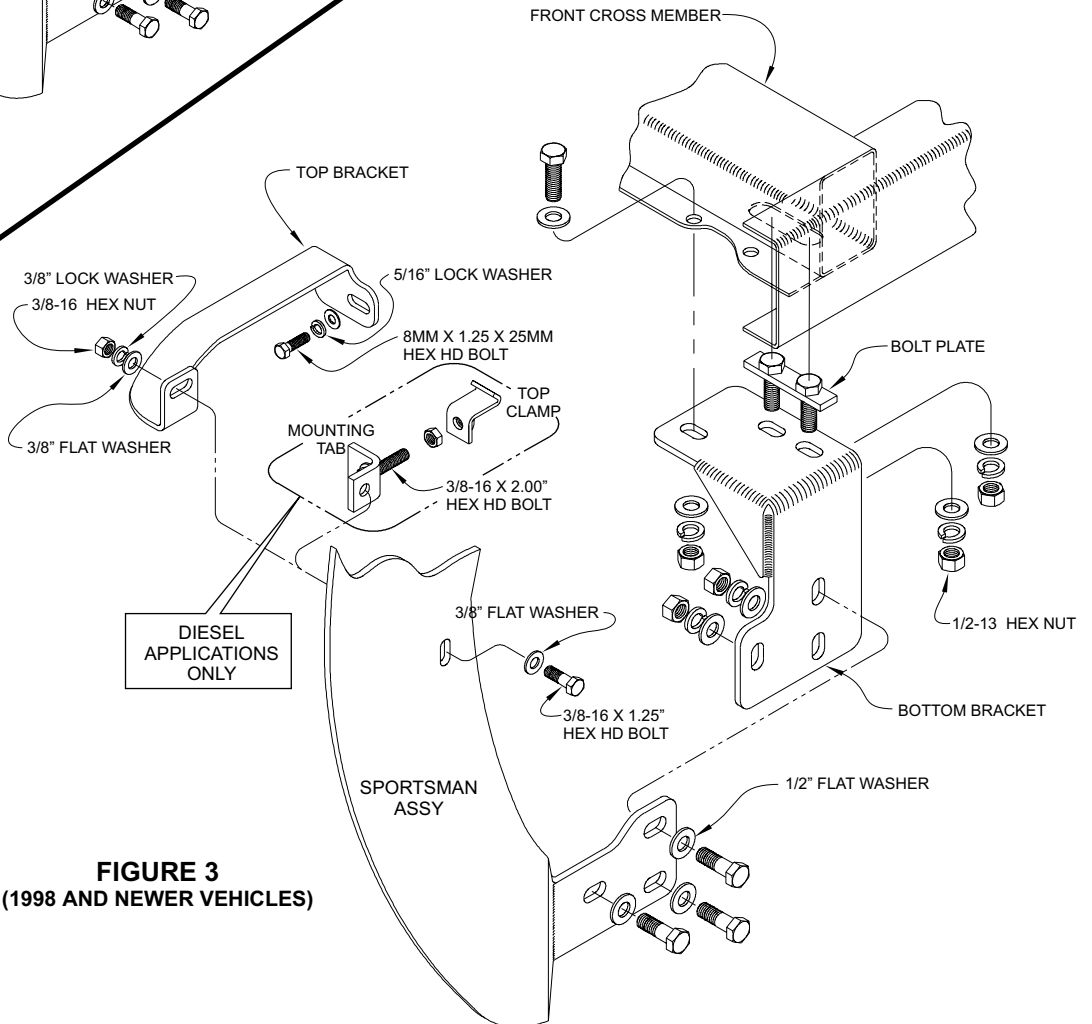

FIGURE 3
(1998 AND NEWER VEHICLES)



Westin Automotive Products, Inc.
5200 N. Irwindale Ave., Suite 220
Irwindale, Ca. 91706

AUTOMOTIVE PRODUCTS, INC.