

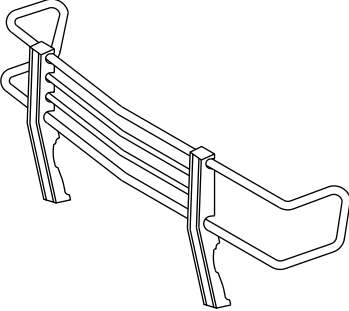

INSTALLATION INSTRUCTIONS

APPLICATION: 1999 FORD F-SERIES LIGHT DUTY AND EXPEDITION
(4X4 WITH TOW HOOKS ONLY)

AUTOMOTIVE PRODUCTS, INC.

<p>CLASSIC GRILLE GUARD ASSEMBLY</p> <p>35-1370 35-1380</p>		
QTY	PARTS KIT CONTENTS DESCRIPTION	TOOLS REQUIRED
<p>1 1 1 1 1 1 1 1 2 4 8 6 8 4</p>	<p>UPRIGHT - PASSENGER SIDE UPRIGHT - DRIVER SIDE WING - PASSENGER SIDE WING - DRIVER SIDE CENTER SECTION TOP BRACKET - PASSENGER TOP BRACKET - DRIVER BOTTOM BRACKET PROTECTIVE RUBBER STRIP 1/2-13 X 1.25" HEX HEAD BOLTS 1/2" SAE FLAT WASHERS 1/2" SPLIT LOCK WASHERS 12MM JAM NUTS</p>	<p>3/4" SOCKET 15MM SOCKET 19MM SOCKET RATCHET TORQUE WRENCH 3/4" WRENCH SOCKET EXTENSION</p>

Step 1. Remove the contents from the box and check for any damage. Verify all parts against the parts list.

Step 2. Read and understand instructions completely before beginning installation.

Step 3. To assemble the grille guard, position the center section, See Figure 1 for proper orientation. The bottom side of the center section is the longer end. Insert wings so that wing slots line up with center section holes. Attach uprights to grille guard center assembly using 1/2" hex head bolts, flat washers, and lock washers. **Hand tighten.** Place Protective Rubber Strips on uprights where contact to vehicle occurs.

Note: When Grille Guard is positioned against vehicle, the outer wing profiles should match the vehicle head-lamp/turn lamp assembly. If not, reverse wings in center section side to side.

Step 4. At tow hook, loosen rear bolt and remove front bolt. Install the bottom bracket between the frame and tow hook with the thick end of bracket toward center of vehicle. Re-insert bolt (leave loose). Repeat step on opposite side.

Step 5. From inside of frame behind bumper, position bracket so that front of bracket protrudes between top of bumper and bottom of grille. (If necessary, push down on bumper cover plastic to slide bracket through.) Locate bumper bolt ends (front side of frame), then position bracket slots on bolt ends, over existing nuts,

Hand tighten supplied 12mm jam nuts over bracket. Repeat step on opposite side.

Step 6. Take assembled Grille Guard and place against vehicle, align all brackets with threaded inserts on uprights. Bolt up loosely using remaining 1/2" hardware. (Use no flat washers on top brackets).

Step 7. Adjust Grille Guard so centered and level and torque all hardware to: 1/2" fasteners to 65 ft. lbs; 12mm nuts to 60 ft. Lbs; tow hook bolts 75 ft.lbs.

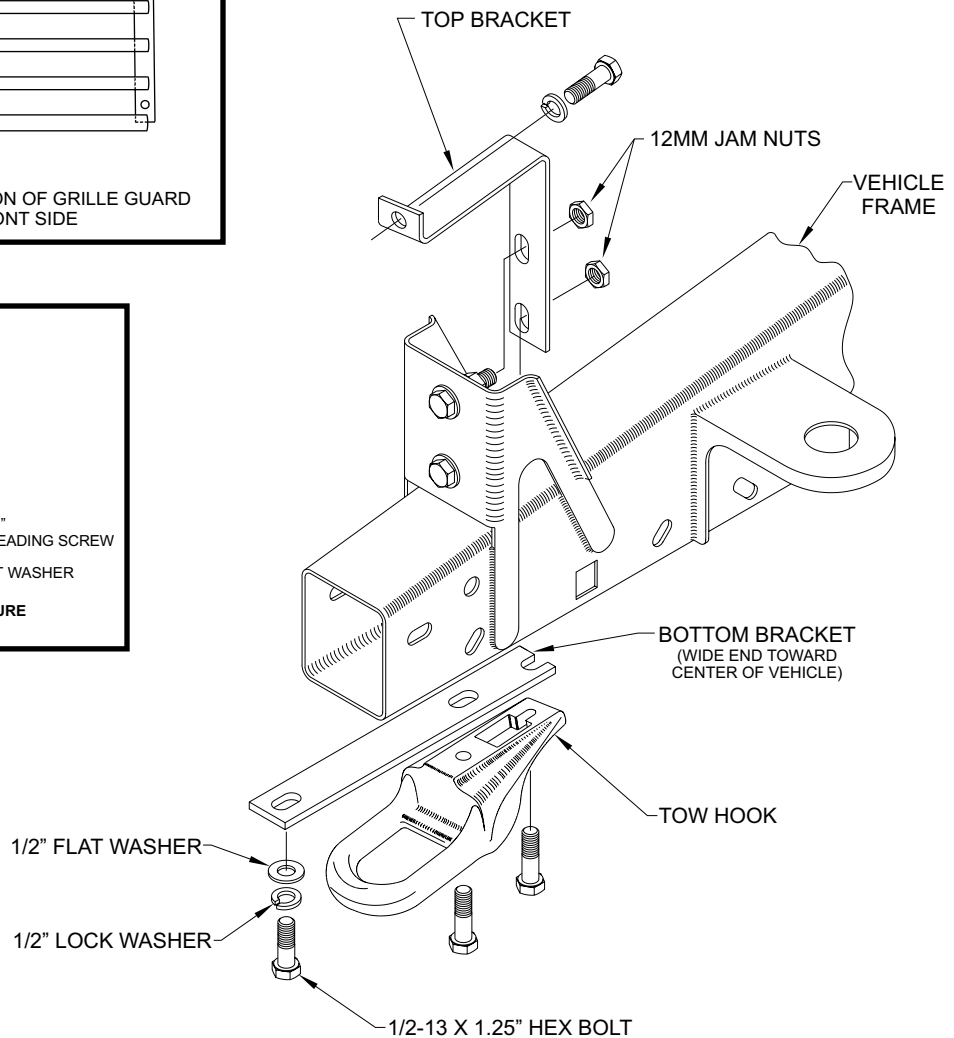
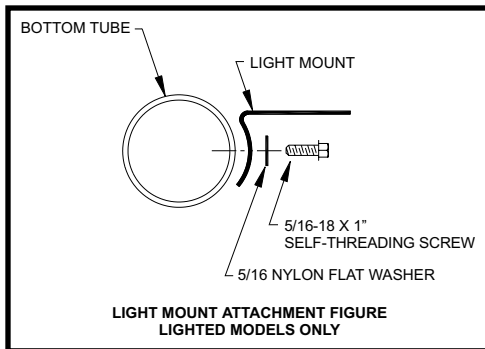
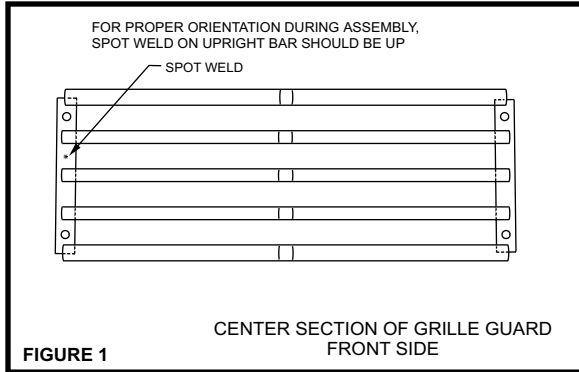

DRIVER SIDE INSTALLATION SHOWN - PASSENGER SIDE OPPOSITE

Finish protection - Westin products have a high quality finish that must be cared for like any other exposed finish on the vehicle. Protect the finish with a non-abrasive automotive wax (pure carnauba, for example) on a regular basis. The use of cleaner wax or any compound which contains an abrasive is detrimental, as the compounds scratch the finish and open it to corro-

75-0224 PAGE 2 OF 2
REVISION A 7/13/99



Westin Automotive Products, Inc.
5200 N. Irwindale Ave. Suite 220
Irwindale, Ca. 91706

Thank You for choosing Westin products
For additional installation assistance please call
Customer service (800) 793-7846 or (507) 375-3559