



INSTALLATION INSTRUCTIONS

APPLICATION: 1999 CHEVROLET SILVERADO 1500 SERIES
2/4 WHEEL DRIVE

AUTOMOTIVE PRODUCTS, INC.

CLASSIC GRILLE GUARD ASSEMBLY 35-1300 35-1310	
---	--

QTY	PARTS KIT CONTENTS DESCRIPTION	TOOLS REQUIRED
1	UPRIGHT - PASSENGER SIDE	3/4" SOCKET 18MM SOCKET 19MM SOCKET 10MM SOCKET RATCHET TORQUE WRENCH PHILLIPS SCREWDRIVER SMALL FLAT SCREWDRIVER SOCKET EXTENSION
1	UPRIGHT - DRIVER SIDE	
1	WING - PASSENGER SIDE	
1	WING - DRIVER SIDE	
1	CENTER SECTION	
1	TOP BRACKET - PASSENGER	
1	TOP BRACKET - DRIVER	
1	BOTTOM BRACKET - PASSENGER	
1	BOTTOM BRACKET - DRIVER	
4	PROTECTIVE RUBBER STRIP	
6	1/2-13 X 1.50" HEX HEAD BOLTS	
10	1/2" SAE FLAT WASHERS	
10	1/2" SPLIT LOCK WASHERS	
2	1/2-13 BOLT PLATES	
2	M12-1.75 X 90MM LG HEX HEAD BOLTS	
2	1/2-13 HEX NUTS	
2	SPACER TUBES	
2	STIFFENER BRACKET - PASSENGER/DRIVER	

Step 1. Remove the contents from the box and check for any damage. Verify all parts against the parts list.

Step 2. Read and understand instructions completely before beginning installation.

Step 3. To assemble the grille guard, position the center section, See **Figure 4** for proper orientation. The bottom side of the center section is the longer end. Insert wings so that the wing slot lines up with the center section hole. Attach uprights to grille guard through top holes only using 1/2" hex head bolts, flat washers, and lock washers. **Hand tighten.** Place Protective Rubber Strips on uprights where contact to vehicle occurs.

Note: When Grille Guard is positioned against vehicle, the outer wing profiles should match the vehicle head-lamp/turnlamp assembly. If not, reverse wings in center section side to side.

Step 4. Remove plastic shroud above grille by removing the seven pin retainers. Pull center pin up with small flat screwdriver. See **Figure 1**.

Step 5. Remove grille from truck by removing 10mm bolt from top of grille. Turn the four retainers ¼ turn counter-clockwise with Phillips screwdriver. Pull on outer edge of grille by applying firm pressure away from the fender, repeat on the opposite side. Carefully remove grille from vehicle.

Step 6. To install top brackets and stiffener brackets, remove the 12mm bumper bolts from top of frame located behind the top side of bumper. Remove two 6mm bolts in radiator support frame located just above the bumper bolts. Install spacer tube, top bracket, and stiffener bracket as shown in **Figure 2** using the 12mm x 1.75 x 90mm Hex Head Bolt, ½" lock washer, and ½" flat washer. Attach top of stiffener bracket between the transmission cooler cross brace and radiator support bar with original bolt. **Figure 2.**

Note: For models without tow hooks, insert ½" Bolt Plate inside frame with bolt protruding through the hole in the bottom of frame. Attach Bottom Mount Bracket to Bolt Plate. **Figure 3.**

Step 7. Raise the Grille Guard up to the Brackets and attach using the remaining ½" hardware and hand tighten. Adjust Grille Guard to Center on truck and torque all fasteners at the frame locations only to: ½" fasteners = 65 FT. LBS; 12mm fasteners = 60 FT. LBS.

Step 8. Remove Grille Guard from Brackets and re-install vehicle grille and plastic shroud in the opposite order of removal.

Step 9. Re-attach Grille Guard to Brackets and tighten the remaining ½" bolts to 65 FT. LBS.

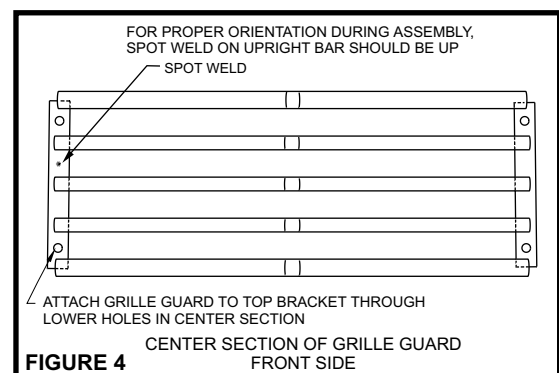
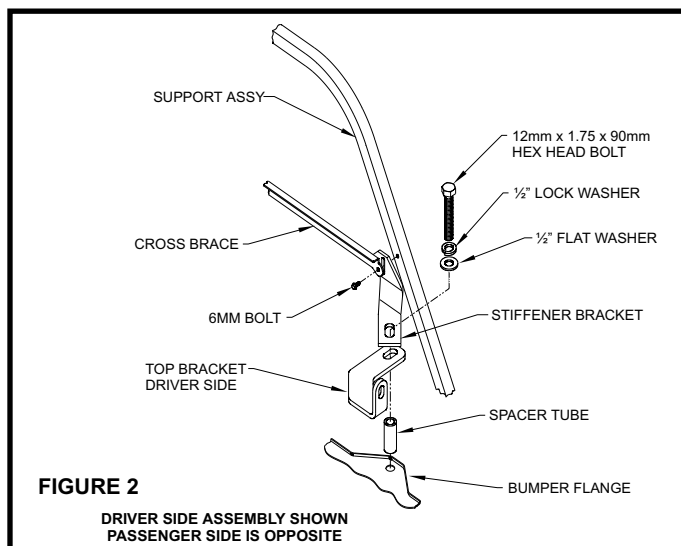
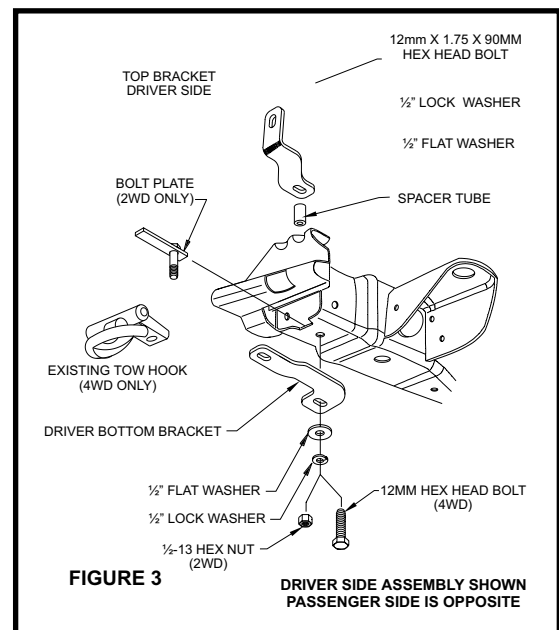
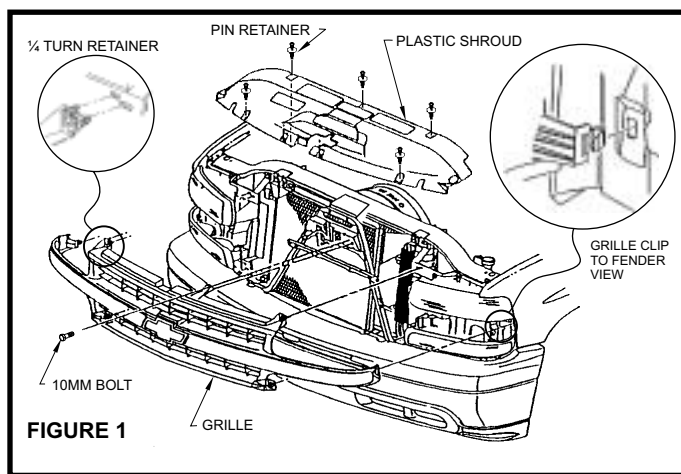

Finish protection - Westin products have a high quality finish that must be cared for like any other exposed finish on the vehicle. Protect the finish with a non-abrasive automotive wax (pure carnauba, for example) on a regular basis. The use of cleaner wax or any compound which contains an abrasive is detrimental, as the compounds scratch the finish and open it to corrosion.