



INSTALLATION INSTRUCTIONS

APPLICATION: 1999- 2000 F250/ F350 SUPERDUTY
2000 FORD EXCURSION

AUTOMOTIVE PRODUCTS, INC.

GRILLE GUARD
ASSEMBLIES

35-1330
35-1340



QTY	PARTS KIT CONTENTS DESCRIPTION	TOOLS REQUIRED
1	GRILLE GUARD CENTER SECTION	TAPE MEASURE
1	MOUNT BRACKET - PASSENGER	3/4" SOCKET
1	MOUNT BRACKET - DRIVER SIDE	5/16" HEX KEY SOCKET (ALLEN)
4	1/2 -13 X 1.50" LG. HEX HEAD BOLT	TORQUE WRENCH
4	1/2" FLAT WASHER	RATCHET
4	1/2 -13 X 1.00" S.S. BUTTON HEAD BOLT	SOCKET EXTENSION
4	1/2" S.S. INTERNAL TOOTH LOCK WASHER	18MM SOCKET
1	PASSENGER WING	
1	DRIVER WING	
1	PASSENGER UPRIGHT	
1	DRIVER UPRIGHT	

- STEP 1. REMOVE THE CONTENTS FROM THE BOX AND CHECK FOR ANY DAMAGE. VERIFY ALL PARTS AGAINST PARTS LIST.
- STEP 2. READ AND UNDERSTAND INSTRUCTIONS COMPLETELY BEFORE BEGINNING INSTALLATION.
- STEP 3. ASSEMBLE GRILLE GUARD BY INSERTING THE OUTER WINGS INTO THE CENTER SECTION, UNTIL THE SLOTS IN THE WINGS LINE UP WITH THE HOLES IN THE CENTER SECTION. ATTACH THE UPRIGHTS TO THE GRILLE GUARD USING THE 1/2" HEX HEAD BOLTS AND FLAT WASHERS. LEAVE LOOSE. (WHEN ASSEMBLED, THE WINGS ARE INTENDED TO FOLLOW THE PROFILE OF THE HEADLIGHT ASSY.)
- STEP 4. LOOSEN FRONT BUMPER BOLTS (APPROX 3/8") (FIG. 1) WHILE PUSHING BUMPER TOWARD TRUCK TO

HELP PREVENT RETAINING CLIPS FROM ROTATING BENEATH THE BUMPER.

- STEP 5. INSTALL THE BRACKET AS SHOWN. LEAVE BRACKET LOOSE ENOUGH FOR ADJUSTMENT.
- STEP 6. FOLLOW STEPS 3 - 5 FOR OPPOSITE SIDE.
- STEP 7. MEASURE DISTANCE BETWEEN ASSEMBLED GRILLE GUARD UPRIGHTS AT INSIDE WHERE SLOTS ARE.
- STEP 8. POSITION BRACKETS ON TRUCK (FIG. 2) ACCORDING TO THE MEASURED WIDTH OF THE UPRIGHTS AND AT THE SAME TIME POSITION BUMPER IN DESIRED POSITION. TIGHTEN AND TORQUE BOLTS ON TRUCK TO 65 FT. LBS.
- STEP 9. PLACE GRILLE GUARD UNIT UP AGAINST TRUCK AND ALIGN SO THAT THE BUTTON HEAD SCREWS AND INTERNAL TOOTH LOCK WASHERS CAN BE INSTALLED IN THE MOUNT BRACKETS. FIG. 3.
- STEP 10. POSITION UNIT AS DESIRED AND TORQUE REMAINING BOLTS TO 65 FT. LBS.

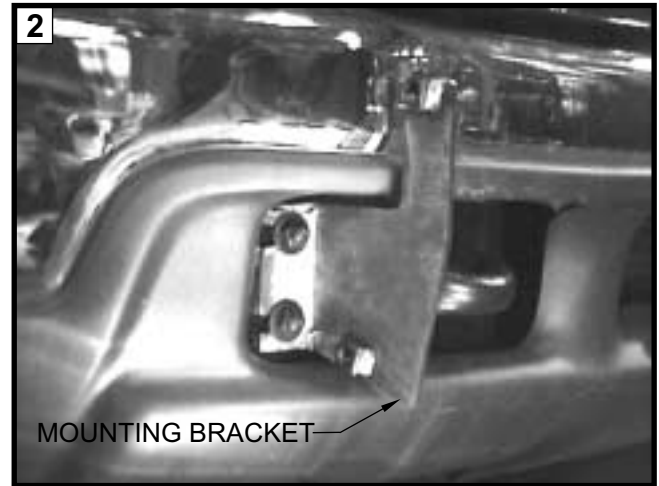
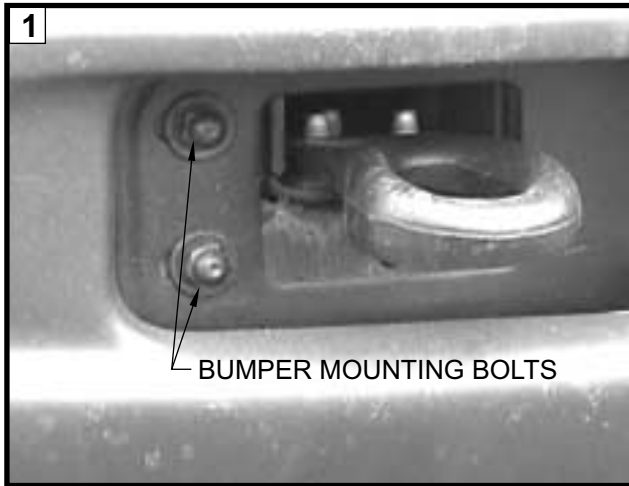

INSTALLATION OF PASSENGER SIDE IS SHOWN

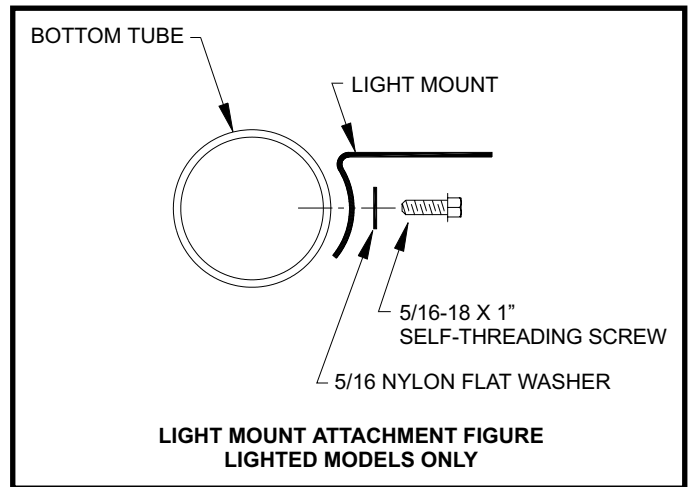
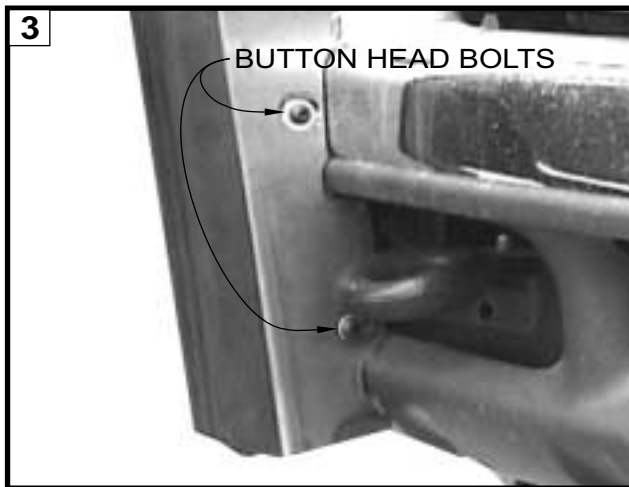

Finish protection - Westin products have a high quality finish that must be cared for like any other exposed finish on the vehicle. Protect the finish with a non-abrasive automotive wax (pure carnauba, for example) on a regular basis. The use of cleaner wax or any compound which contains an abrasive is detrimental, as the compounds scratch the finish and open it to corrosion.