



INSTALLATION INSTRUCTIONS

APPLICATION: 1996 - 98 FORD EXPLORER
 1997 - 98 MERCURY MOUNTAINEER
 1998 FORD RANGER

AUTOMOTIVE PRODUCTS, INC.

SAFARI BAR
 ASSEMBLY:

30-0005

MOUNT KIT:

30-1055

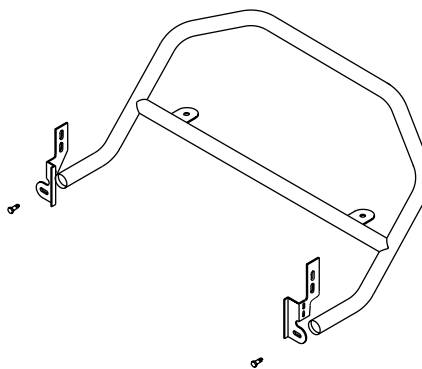

QTY	PARTS KIT CONTENTS DESCRIPTION	TOOLS REQUIRED
2	MOUNT BRACKET - DRIVER / PASSENGER	10 MM SOCKET
2	SUPPORT BRACKET - DRIVER / PASSENGER	1/2" SOCKET
2	BACKING PLATE	9/16" WRENCH
2	1/2"-13 X 4.0" HEX HEAD BOLT	9/16" SOCKET
2	1/2"-13 X 2.0" HEX HEAD BOLT	3/4" WRENCH
2	3/8"-16 X 1.5" HEX HEAD BOLT	3/4" SOCKET
4	5/16"-18 X 1.0" SELF TAP BOLT	TORQUE WRENCH
6	1/2" FLAT WASHER	RATCHET
4	1/2" LOCK WASHER	RATCHET EXTENSION
2	1/2"-13 FINISHED NUT	
4	3/8" FLAT WASHER	
2	3/8" LOCK WASHER	

- STEP 1. REMOVE THE CONTENTS FROM THE BOX AND CHECK FOR ANY DAMAGE. VERIFY ALL PARTS AGAINST PARTS LIST.
- STEP 2. READ AND UNDERSTAND INSTRUCTIONS COMPLETELY BEFORE BEGINNING INSTALLATION.
- STEP 3. INSTALL MOUNT BRACKETS ON THE OUTSIDE FACE OF FRAME MEMBERS WITH 1/2-13 X 4.00" HEX HEAD BOLTS. **NOTE: 4- DOOR APPLICATIONS USE UPPER HOLES (FIG. 1). NOTE: EXPLORER "SPORT" AND RANGER USES LOWER HOLES (FIG. 2).** SECURE TO FRAME WITH BACKING PLATES AND 1/2" FASTENERS (FIG. 3). LEAVE LOOSE
- STEP 4. INSTALL SUPPORT BRACKETS USING HOLES IN BOTTOM FACE OF TRUCK FRAME. '96-'97; SECURE TO FRAME USING 5/16" SELF TAP BOLTS. (FIG'S 1,2). '98; VEHICLES HAVE A FACTORY BOLT IN REAR HOLE TO HOLD RADIATOR SHROUD. (FIG'S 1,2). REMOVE WITH 10MM SOCKET. REMOVE

"PUSH TYPE" FASTENER HOLDING REAR OF SHROUD TO FRAME. INSTALL SUPPORT BRACKET BETWEEN TOP OF SHROUD AND FRAME. REPLACE FACTORY BOLT. REPLACE PUSH TYPE CONNECTOR WITH 5/16" SELF TAPPING BOLT. LEAVE LOOSE.

STEP 5. SECURE SUPPORT BRACKET TO MOUNT BRACKET USING 3/8" FASTENERS. (FIG'S 1,2).

STEP 6: MOUNT SAFARI BAR USING 1/2" FASTENERS. (FIG'S 1-4).

STEP 7: CENTER AND LEVEL SAFARI BAR. TIGHTEN AND TORQUE FASTENERS AS FOLLOWS: (5/16" & 8MM = 15 FT-LBS) (3/8" = 35 FT-LBS) (1/2" = 65 FT-LBS)

FIGURE 1
4 DOOR APPLICATIONS
DRIVER SIDE SHOWN

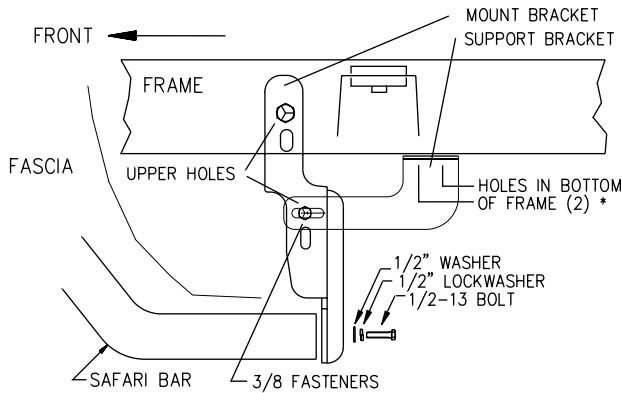

* 98 MODELS HAVE FACTORY BOLT IN REAR HOLE AND A "PUSH TYPE" FASTENER IN FRONT HOLE

FIGURE 2
EXPLORER SPORT & RANGER
DRIVER SIDE SHOWN

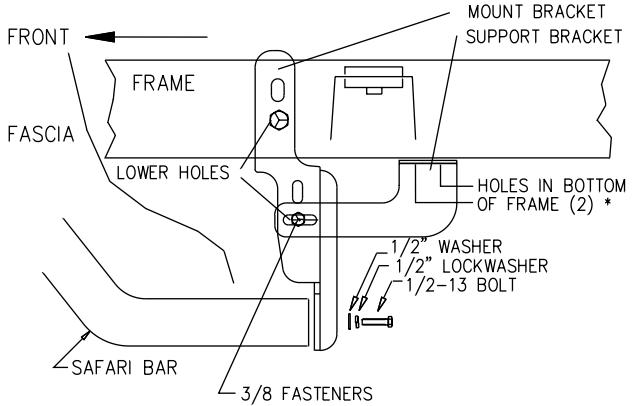

* 98 MODELS HAVE FACTORY BOLT IN REAR HOLE AND A "PUSH TYPE" FASTENER IN FRONT HOLE

FIGURE 3
DRIVERS SIDE SHOWN

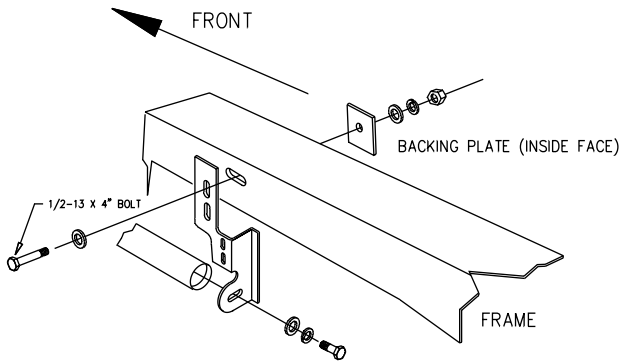
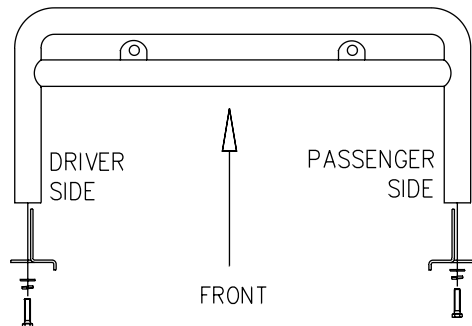

FIGURE 4
TOP VIEW



Finish protection - Westin products have a high quality finish that must be cared for like other exposed finish on the vehicle. Protect the finish with a non-abrasive automotive wax (pure carnauba, for example) on a regular basis. The use of cleaner wax or any compound which contains an abrasive is detrimental, as the compounds scratch the finish and open it to corrosion.

