



INSTALLATION INSTRUCTIONS

APPLICATION: 1997-UP FORD F-150, F-250(LD) EXTENDED/
REGULAR CAB

AUTOMOTIVE PRODUCTS, INC.

STEP BAR ASSEMBLIES

- 25-1100
- 25-1105
- 25-1110
- 25-1115
- 25-1280
- 25-1290
- 25-1430
- 25-1435
- 26-1110
- 26-1430

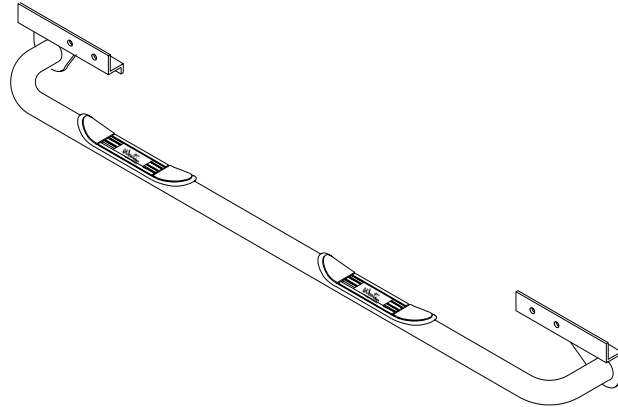

QTY	PARTS KIT CONTENTS DESCRIPTION	TOOLS REQUIRED
1	STEP BAR - PASSENGER SIDE	9/16" SOCKET 3/4" SOCKET 3/4" COMBINATION WRENCH TORQUE WRENCH RATCHET
1	STEP BAR - DRIVER SIDE	
1	FRONT MOUNT BRACKET - PASSENGER SIDE	
1	FRONT MOUNT BRACKET- DRIVER SIDE	
1	REAR MOUNT BRACKET - PASSENGER SIDE	
1	REAR MOUNT BRACKET - DRIVER SIDE	
2	FRONT SUPPORT STRAP	
2	REAR SUPPORT STRAP (L/ R)	
4	1/2 -13 X 2.50" LG. HEX HEAD BOLT	
4	1/2 13 X 1.50" LG. HEX HEAD BOLT	
4	1/2 -13 NUT	
12	1/2" FLAT WASHER	
8	1/2" LOCK WASHER	
8	3/8 -16 NUT, FLAT WASHERS, LOCK WASHERS	
4	BOLT PLAT - LARGE	
1	SMALL BOLT PLATE ('97 & '98 EXT. CAB ONLY)	

- STEP 1. REMOVE THE CONTENTS FROM THE BOX AND CHECK FOR ANY DAMAGE. VERIFY ALL PARTS AGAINST PARTS LIST.
- STEP 2. READ AND UNDERSTAND INSTRUCTIONS COMPLETELY BEFORE BEGINNING INSTALLATION.
- STEP3. REMOVE BLACK RUBBER PLUGS OVER TWO HOLES (THREE ON '97 & '98 EXTENDED CAB DRIVER SIDE) ON EACH INSIDE FACE OF SHEET METAL ROCKER PANEL. FIGURE 1.

- STEP 4. INSTALL FRONT MOUNTING BRACKET BY PLACING BOLT PLATE (LARGER) THROUGH HOLE IN BODY AS SHOWN IN FIGURE 1. POSITION FRONT BRACKET WITH DOWNWARD SLOPING END TOWARDS FRONT OF VEHICLE. ASSEMBLE WITH (2) 3/8" FLAT WASHERS, (2) 3/8" LOCK WASHERS AND (2) 3/8 -16 HEX NUTS. FIGURE 1. LEAVE LOOSE.
- STEP 5. INSTALL REAR MOUNTING BRACKET SAME AS FRONT ONLY WITH DOWNWARD SLOPING END FACING REAR OF VEHICLE. BOLT PLATE USES TWO UPPER HOLES IN EACH REAR BRACKET. **NOTE: '97 & '98 EXTENDED CAB LEFT REAR BRACKET REQUIRES SPECIAL SMALLER BOLT PLATE. THIS USES THE TWO LOWER HOLES IN BRACKET.** FIGURE 1.
- STEP 6. POSITION SUPPORT STRAPS BETWEEN BODY AND NEW BRACKETS. FIGURES 2 AND 3. SECURE WITH (1) 1/2 -13 X 1.50" LG. HEX HEAD BOLT, (2) 1/2" FLAT WASHERS, (1) 1/2" LOCK WASHER AND (1) 1/2 -13 HEX NUT. FIGURES 2 AND 3. LEAVE LOOSE.
- STEP 7. PLACE STEP BAR TUBE UP TO FRONT AND REAR BRACKETS AND FASTEN WITH (2) 1/2 -13 X 2.50" LG. HEX HEAD BOLTS, (2) 1/2" FLAT WASHERS AND (2) 1/2" LOCK WASHERS. FINGER TIGHTEN.
- STEP 8. CHECK TO BE SURE STEP BAR IS PROPERLY ALIGNED WITH TRUCK, THEN TIGHTEN AND TORQUE MOUNTING BRACKET BOLTS AS FOLLOWS: (1/2 - 13 BOLTS - 65 FT/LBS.) (3/8 - 16 - 28 FT/LBS.)

FIGURE 1

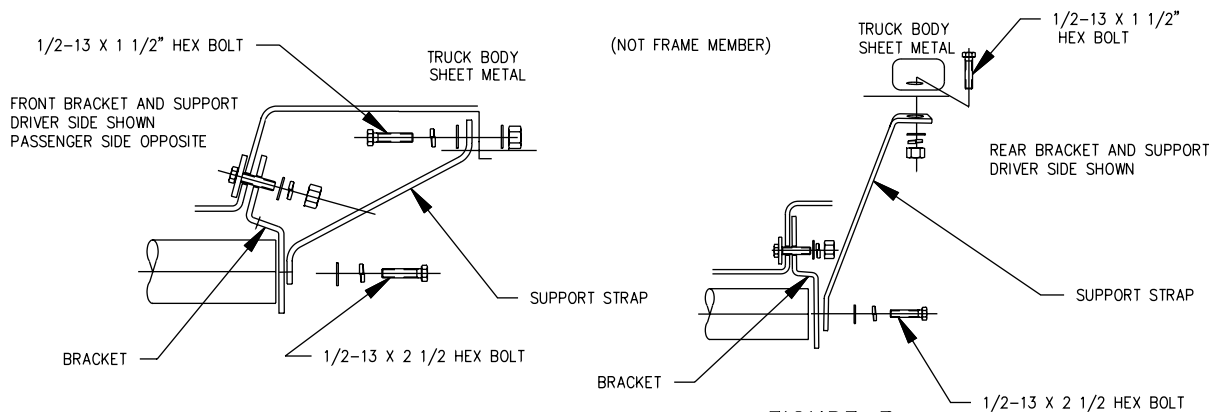
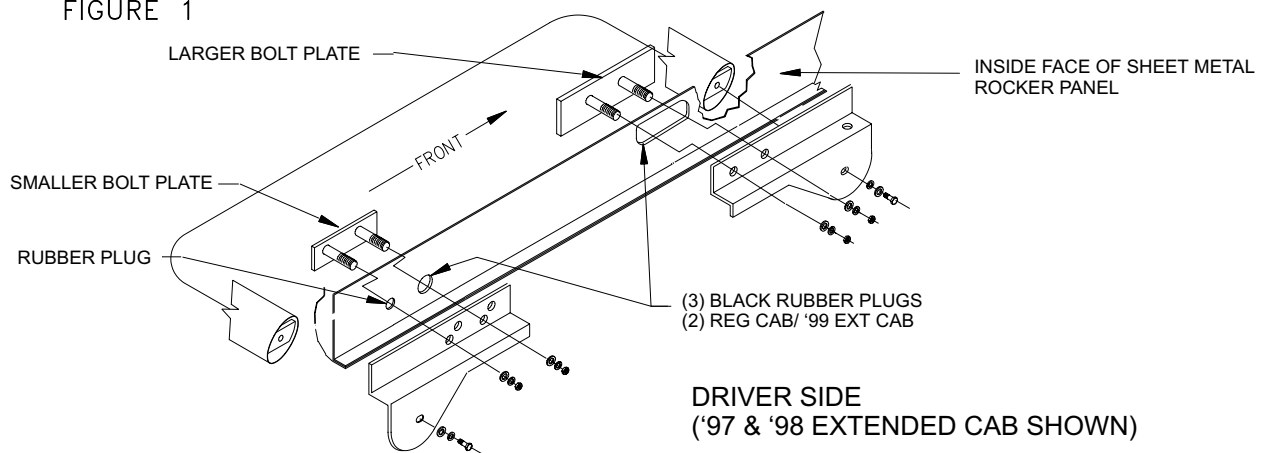

FIGURE 2

FIGURE 3

*** PATENT PENDING**

Finish protection - Westin products have a high quality finish that must be cared for like any other exposed finish on the vehicle. Protect the finish with a non-abrasive automotive wax (pure carnauba, for example) on a regular basis. The use of cleaner wax or any compound which contains an abrasive is detrimental, as the compound scratches the finish and opens it to corrosion.

* MOUNTING CONFIGURATION ONLY

75-0185 PAGE 2 OF 2
Revision C 05/18/99



Westin Automotive Products, Inc.
5200 N. Irwindale Ave. Suite 220
Irwindale, Ca. 91706

Thank You for choosing Westin products
For additional installation assistance please call
Customer service (800) 793-7846 or (507) 375-3559