



# INSTALLATION INSTRUCTIONS

APPLICATION: 1997-04 FORD F-150/250 PICKUP (HERITAGE)  
1999-04 FORD F-250/350 SUPERDUTY

**AUTOMOTIVE PRODUCTS, INC.**

SPORTSMAN TAIL LIGHT GUARD	QTY	PART KIT CONTENTS DESCRIPTION
<b>CHROME</b> <b>BLACK</b> 39-3090        39-3095	1	TAIL LIGHT GUARD - DRIVER
	1	TAIL LIGHT GUARD - PASSENGER
	2	PLASTIC RETAINER CLIPS
	8	#8 SELF-DRILLING SCREWS

- STEP 1. Remove the contents from box and check for damage. Verify all parts are present. Read instructions completely before beginning.
- STEP 2. Snap plastic retainer clips onto third wire from top of both tail light guards.
- STEP 3. Open tailgate to gain access to tailgate jamb. Center taillight guard over taillight and adjust bracket so retainer clip rests snugly against lens.
- STEP 4. It is advisable to have help while drilling and mounting tail light guards in order to avoid installing incorrectly of "crooked" on your vehicle. With helper's assistance, hold taillight guard in position and carefully attach and secure taillight guard one screw at a time until all four have been attached. Carefully close tailgate making sure taillight guard does not interfere with operation of tailgate opening and closing. Remove backing tape from base of retainer clips and press firmly against taillight lens.
- STEP 5. Repeat installation for opposite side.

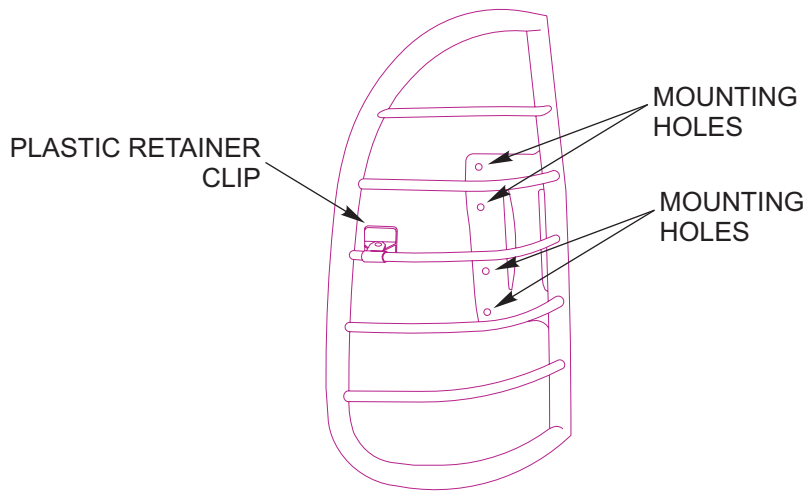

Finish protection - Westin products have a high quality finish that must be cared for like any other exposed finish on the vehicle. Protect the finish with a non-abrasive automotive wax (pure carnauba, for example) on a regular basis. The use of cleaner wax or any compound which contains an abrasive is detrimental, as the compounds scratch the finish and open it to corrosion.



Westin Automotive Products, Inc.  
5200 N. Irwindale Ave. Suite 220  
Irwindale, Ca. 91706

Thank You for choosing Westin products  
For additional installation assistance please call  
Customer service (800) 793-7846 or (507) 375-3559