

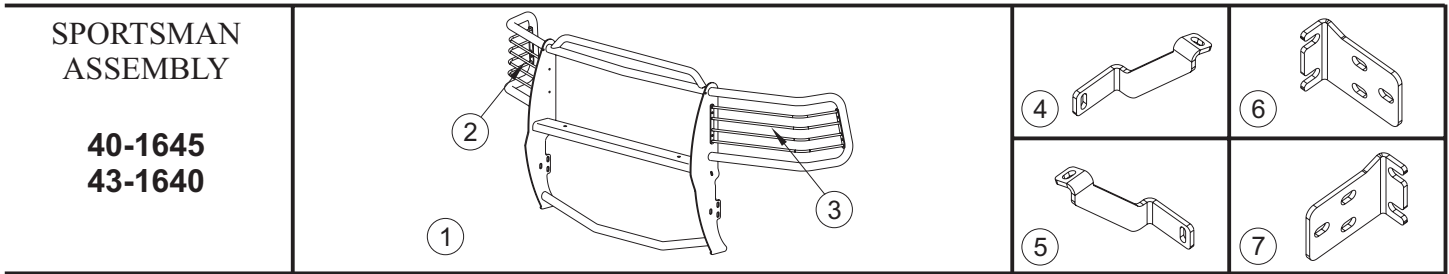

INSTALLATION INSTRUCTIONS

APPLICATION: 2005-UP FORD F-250/350 SUPERDUTY
2005-UP FORD EXCURSION

AUTOMOTIVE PRODUCTS, INC.



PARTS KIT CONTENTS

ITEM	QTY	DESCRIPTION	ITEM	QTY	DESCRIPTION
1	1	SPORTSMAN ASSEMBLY	15	8	3/8" FLAT WASHER
2,3	2	LIGHT GUARD ASSEMBLY, PASSENGER(2) AND DRIVER(3)	16	4	3/8" LOCK WASHER
4,5	2	TOP BRACKET, PASSENGER(4) AND DRIVER(5)	17	4	3/8-16 HEX NUT
6,7	2	BOTTOM BRACKET, PASSENGER(6) AND DRIVER(7)	18	2	5/16-18 X 1.75" HEX HEAD BOLT
8	2	SPACER TUBE	19	4	5/16" FLAT WASHER
9	6	1/2-13 X 1.25" HEX HEAD BOLT	20	2	5/16" LOCK WASHER
10	12	1/2" FLAT WASHER	21	2	5/16-18 HEX NUT
11	6	1/2" LOCK WASHER	22	2	ANTI-REFLECTIVE TAPE (FOR CHROME ASSEMBLIES ONLY.)
12	6	1/2-13 HEX NUT			NOTE:
13	2	3/8-16 X 1.25" BUTTON HEAD BOLT			SOME FASTENERS MAY NOT BE USED.
14	4	3/8-16 X 1.25" HEX HEAD BOLT			

TOOLS REQUIRED

9/16" SOCKET	9/16" WRENCH	1/2" SOCKET	1/2" WRENCH	7/16" WRENCH
5/32" HEX WRENCH	18MM SOCKET	6" EXTENSION	RATCHET	TORQUE WRENCH

- STEP 1. Remove the contents from box and check for damage. Verify all parts are present. Read instructions completely before beginning.
- STEP 2. Attach light guard assemblies as shown. **SEE FIGURE 1.**
- STEP 3. Loosen front bumper bolts (approximately 3/8") while pushing bumper toward vehicle to help prevent retaining clips from rotating beneath the bumper. Attach bottom brackets as shown. Leave bracket loose enough for adjustment. **SEE FIGURE 2.**
- STEP 4. Measure distance at the inside of the uprights on grille guard.
- STEP 5. Position brackets on vehicle according to the measured width of the upright. At the same time, position bumper in desired location. Tighten and torque bolts to vehicle to 65 FT.LBS.
- STEP 6. Place sportsman assembly up against truck and align so that the 1/2" fasteners can be installed in the mount brackets.
- STEP 7. Locate bumper mount plate welded to the end of the frame rail. Place the 5/16 X 1.75" bolt through the hole in the top corner towards the center of vehicle. This is best accessed from the center opening in the bumper. Place one 3/4" spacer on the bolt. Slide top brace between grille and bumper. Secure brace on bolt and spacer with 5/16" flat washer, lock washer and nut. Fasten top brace to grille guard upright with 3/8" hardware. Leave loose. **SEE FIGURE 3.**
- NOTE:** On vehicles with driving lights installed in the bumper, remove the three 8mm bolts that hold the light to the bumper. Move light over to gain access to top bracket mount location. Reinstall lights once top bracket is properly placed and torqued.
- STEP 8. Center and level sportsman as desired. Torque 1/2" fasteners to 65 FT.LBS; 3/8" fasteners to 35 FT.LBS. and 5/16" fasteners to 17 FT.LBS.
- STEP 9. For chrome assemblies. If light glare is being experienced off the wings of the Sportsman, anti-reflective tape has been supplied to reduce glare. With headlights on, note where the reflection is concentrated on the wing. Clean the wing well with a non-abrasive cleaner (rubbing alcohol works the best.) Trim the anti-reflective tape to the appropriate size where the glare was located and apply tape. **SEE FIGURE 1.**

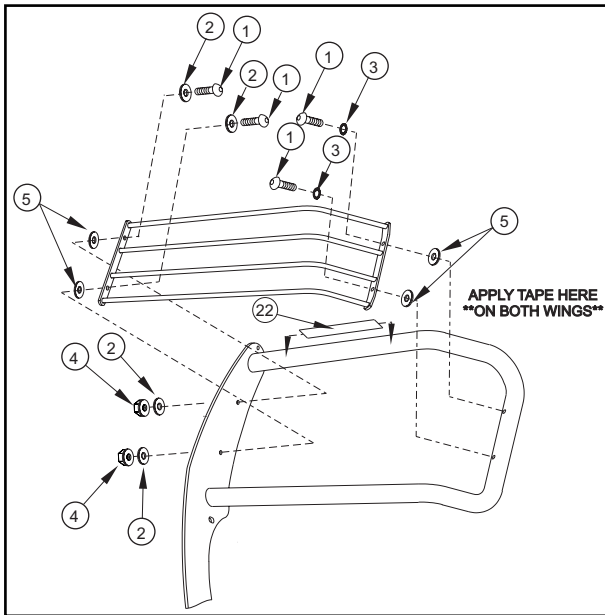

FIGURE 1
LIGHT GUARD INSTALLATION

ITEM	QTY.	DESCRIPTION
1	8	1/4-20 X 1.00" BUTTON HEAD BOLT
2	8	1/4" FLAT WASHER
3	4	1/4" INTERNAL TOOTH LOCK WASHER
4	4	1/4-20 NYLON NUT
5	8	RUBBER WASHER

NOTE: ALL FASTENERS MAY NOT BE USED.

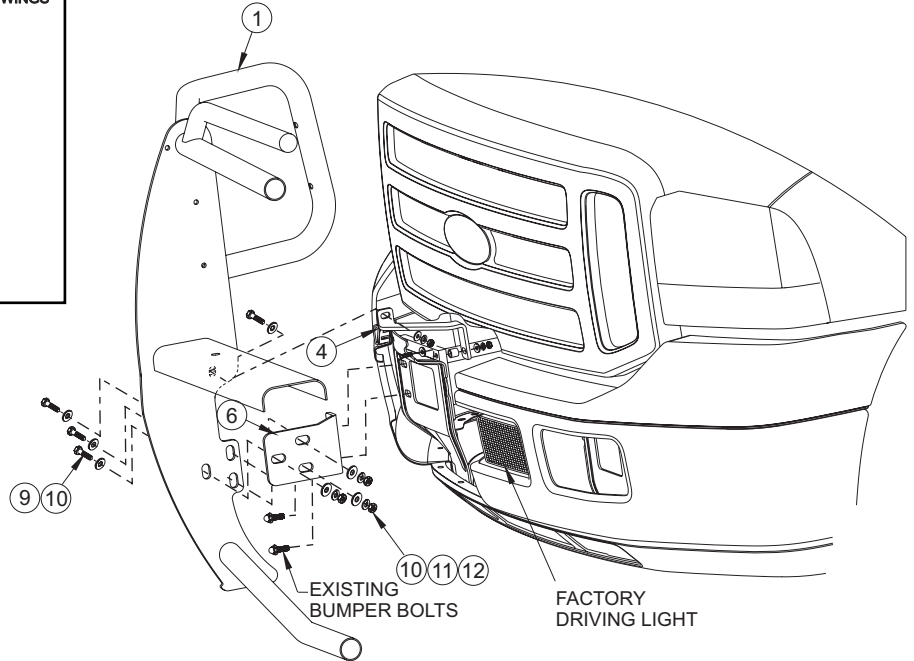

FIGURE 2
INSTALLATION OF PASSENGER SIDE, DRIVER SIDE OPPOSITE

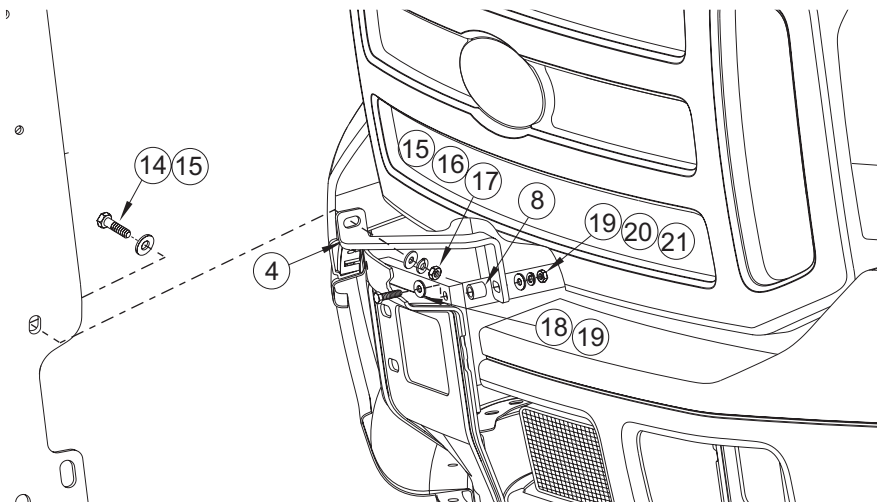

FIGURE 3
TOP BRACKET INSTALLATION, PASSENGER SIDE

Finish protection - Westin products have a high quality finish that must be cared for like any other exposed finish on the vehicle. Protect the finish with a non-abrasive automotive wax (pure carnauba, for example) on a regular basis. The use of cleaner wax or any compound which contains an abrasive is detrimental, as the compounds scratch the finish and open it to corrosion.



Westin Automotive Products, Inc.
5200 N. Irwindale Ave. Suite 220
Irwindale, Ca. 91706

Thank You for choosing Westin products
For additional installation assistance please call
Customer service (800) 793-7846 or (507) 375-3559