



# INSTALLATION INSTRUCTIONS

APPLICATION: 2001-UP FORD EXPLORER SPORT 2DR 2/4WD  
2001-UP FORD EXPLORER SPORT TRAC 4DR 2/4WD

**AUTOMOTIVE PRODUCTS, INC.**

SPORTSMAN  
ASSEMBLY

**44-0800**

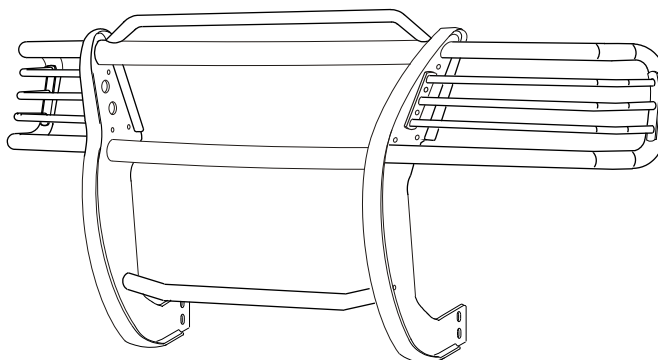

## PARTS KIT CONTENTS

QTY	DESCRIPTION	QTY	DESCRIPTION
2	UPRIGHT	4	2 3/4" OD PLASTIC WASHER
2	WING ASSY. With LIGHT GUARDS	2	1 5/8" OD PLASTIC WASHER
1	TOP TUBE / HOOD BAR ASSEMBLY	2	3/8" NYLON WASHER
1	BOTTOM TUBE	8	1.00" OD PLASTIC WASHER
1	CENTER TUBE	16	3/8" S.S FLAT WASHER
2	LIGHT MOUNT	2	3/8-16 x 1.00" THREAD CUTTING SCREW
2	MOUNT BRACKET	10	3/8-16 x 1.00" BUTTON HEAD CAP
4	1/2-13 x 1.50" SS FLAT HEAD BOLT	2	3/8" INTERNAL TOOTH LOCK WASHER
16	1/2" FLAT WASHER	8	1/2-13 x 1.25" HEX HEAD BOLT
8	1/2" LOCK WASHER	8	1/2-13 HEX NUT
		8	3/8" S.S LOCK NUT

## TOOL REQUIRED

3/4" SOCKET	3/4" WRENCH	RATCHET
15MM SOCKET	TORQUE WRENCH	5/8" WRENCH
5/16" HEX WRENCH	7/32" HEX WRENCH	8MM SOCKET
10MM SOCKET		

- STEP 1. Remove the contents from the box and check for any damage. Verify all parts against the parts list.
- STEP 2. Read and understand instructions completely before beginning installation.
- STEP 3. From the underside of vehicle and behind bumper, remove (4) 8mm bolts and (3) 6mm bolts that secure the plastic shroud.
- STEP 4. Determine Passenger and Driver brackets, remove tow hooks using 15mm socket. **See Figure 2.**  
**NOTE:** Vehicles without tow hooks, attach brackets to frame using (2) 1/2" - 13 x 1.25 Hex Head bolts, (4) 1/2" Flat washers, (2) 1/2" Lock washers and (2) 1/2-13 Hex nuts. Repeat for other side.
- STEP 5. Position bracket between vehicle frame and tow hook. Secure using existing tow hook bolts. Leave loose.
- STEP 6. Determine Passenger/ Driver side Uprights, Top, Center and Bottom Tubes (raised side of bolt holes face each other.) **See Figure 1.**
- STEP 7. Fasten Uprights to Top, Center and Bottom Tubes using (4) 1/2-13 x 1.50" Stainless Steel Flat Head Bolts, (4) 2 3/4" OD Plastic Washers, (2) 3/8-16 x 1.00" Stainless Steel Button Head Cap Screws, (2) 3/8" Stainless Steel Internal Tooth Lock Washers and (2) 1 5/8" OD Plastic Washers. Level tubes and torque: 1/2" fasteners to 60 FT. LBS. and 3/8" fasteners to 30 FT. LBS.

- STEP 8. Align the lower slot on the Center Section with the lower mount bracket slot. Fasten Center Section to bracket using (1) 1/2-13 x 1.25" Hex Head Bolt, (2) 1/2" Flat Washers, (1) 1/2" Lock Washer and (1) 1/2" Hex Nut. Repeat for opposite side. Leave loose.
- STEP 9. Rotate unit up towards vehicle until remaining slots are aligned. Fasten with remaining 1/2" fasteners. Leave loose.
- STEP 10. Level and adjust Center Section. Tighten and torque: Tow Hook Bolts to 75 FT. LBS. and 1/2" fasteners to 65 FT. LBS.
- STEP 11. Reinstall plastic shroud previously removed. Torque 8mm bolts to 87 IN. LBS. and 6mm bolts to 36 IN. LBS.
- STEP 12. Determine Passenger and Driver Wing Assemblies. **See Figure 1.** Install Driver Side Wing Assembly using (4) 3/8-16 x 1.00" Stainless Steel Button Head Cap Screws, (8) 3/8" Flat Stainless Steel Washers, (4) 3/8-16" Stainless Steel Lock Nuts and (4) 1.00" OD Plastic Washers. Tighten and torque to 35 FT. LBS. Repeat for opposite side.

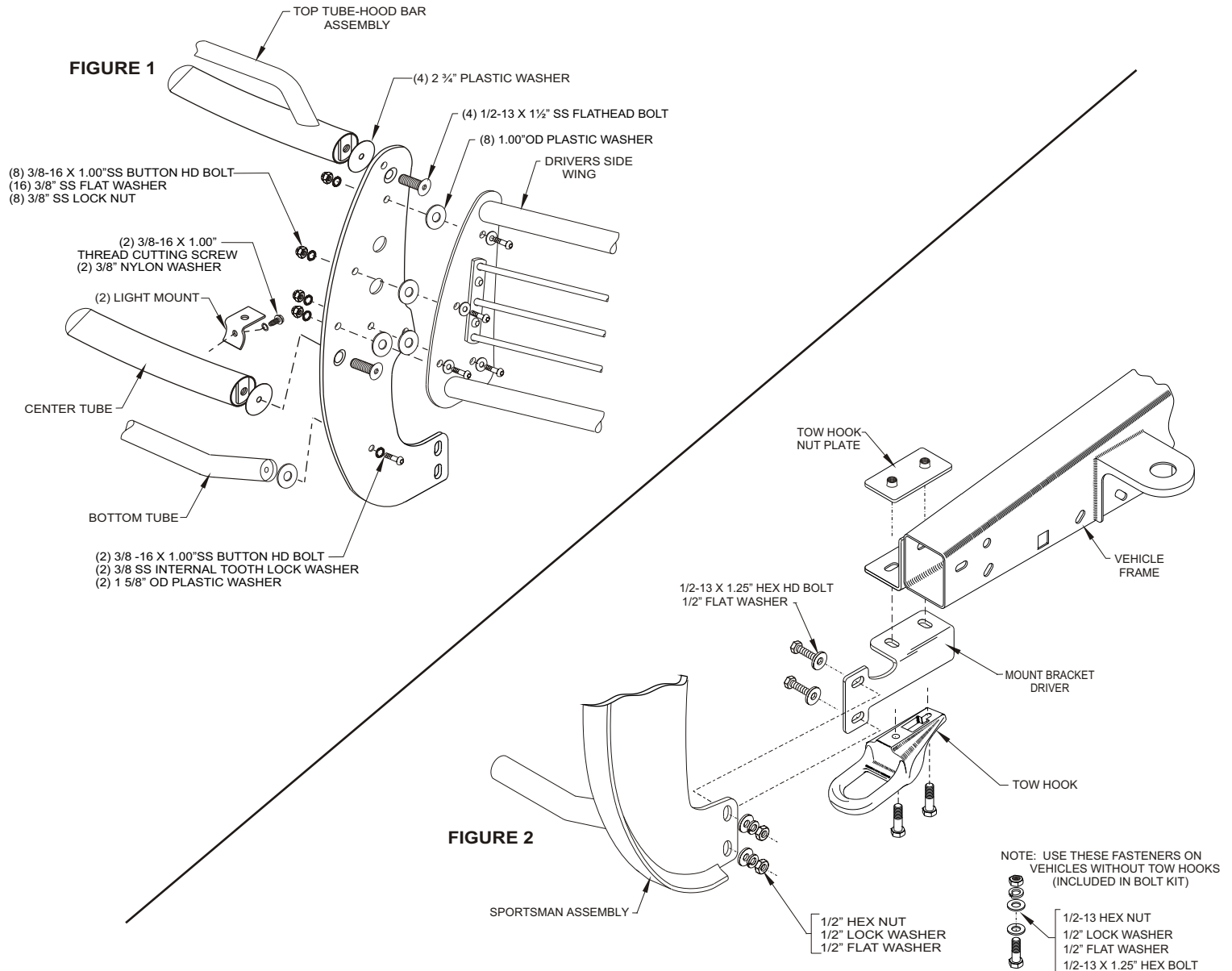

**ASSEMBLY AND INSTALLATION VIEW OF DRIVER SIDE-PASSENGER OPPOSITE**

Finish protection - Westin products have a high quality finish that must be cared for like any other exposed finish on the vehicle. Protect the finish with a non-abrasive automotive wax (pure carnauba, for example) on a regular basis. The use of cleaner wax or any compound which contains an abrasive is detrimental, as the compounds scratch the finish and open it to corrosion.