



INSTALLATION INSTRUCTIONS

APPLICATION: 2001 FORD EXPLORER SPORT 2DR 2/4WD
2001 FORD EXPLORER SPORT TRAC 4DR 2/4WD

AUTOMOTIVE PRODUCTS, INC.

<p>CLASSIC GRILLE GUARD ASSEMBLY</p> <p>35-1490</p>	
--	--

QTY	PARTS KIT CONTENTS DESCRIPTION	TOOLS REQUIRED
1	UPRIGHT - PASSENGER SIDE	8MM SOCKET 10MM SOCKET 15MM SOCKET 3/4" SOCKET RATCHET 3/4"WRENCH 5/16" ALLEN WRENCH TORQUE WRENCH
1	UPRIGHT - DRIVER SIDE	
1	WING - PASSENGER SIDE	
1	WING - DRIVER SIDE	
1	CENTER SECTION	
1	BRACKET - PASSENGER	
1	BRACKET - DRIVER	
4	1/2-13 X 1.50" HEX HEAD BOLT	
4	1/2-13 X 1.00" BUTTON HEAD BOLT	
16	1/2" SAE FLAT WASHER	
4	1/2" INTERNAL TOOTH LOCK WASHER	
6	1/2-13 x 1.25 HEX HEAD BOLT	
6	1/2" SPLIT LOCK WASHER	
6	1/2-13 HEX NUT	
4	PROTECTIVE RUBBER STRIP	
NOTE: SOME FASTENERS MAY NOT BE USED.		

STEP 1. Remove the contents from the box and check for any damage. Verify all parts against the parts list.

STEP 2. Read and understand instructions before beginning installation.

STEP 3. From underside of vehicle and behind bumper remove (4) 8mm bolts and (3) 6mm bolts that secure the plastic shroud.

STEP 4. Determine passenger and driver brackets, remove tow hooks using 15mm socket.

NOTE: For vehicles without tow hooks, attach mount brackets to frame using (2) 1/2-13 x 1.25" Hex Head Bolts, (4) 1/2" Flat Washers, (2) 1/2" Lock Washers and (2) 1/2" Hex Nuts. Install bolts through existing holes in L Bracket on the side of the frame. See Figure 2. Repeat for opposite side.

STEP 5. Position bracket between vehicle frame and tow hook. Fasten using bolts previously removed. Leave loose. Repeat for opposite side.

STEP 6. To assemble Grille Guard, determine top of center section. See Figure 1. Determine passenger and driver side wing, (wings should follow contours of the vehicle turn lamps) and insert so that the wing slot lines up with the center section hole. Fasten uprights to Grille Guard using (4) 1/2-13 x 1.50" Hex Head Bolts and (4) 1/2" Flat Washers. Torque to 65 FT. LBS.

STEP 7. Place protective rubber strips against profiles where contact to vehicle occurs. Position Grille Guard Assembly against vehicle and fasten to mount brackets using (4) 1/2-13 x 1.00" Button Head Bolts and (4) 1/2" Internal Tooth Lock Washers.

STEP 8. Level and adjust unit as desired. Torque tow hook bolts to 75 FT. LBS. and 1/2" Button Head Bolts to 65 FT. LBS.

STEP 9. Reinstall plastic shroud opposite removed. Torque 8mm bolts to 35FT. LBS. And 6mm bolts to 18FT. LBS.

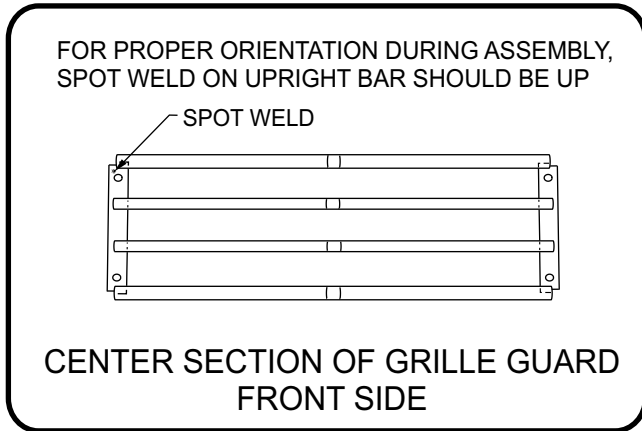

FIGURE 1

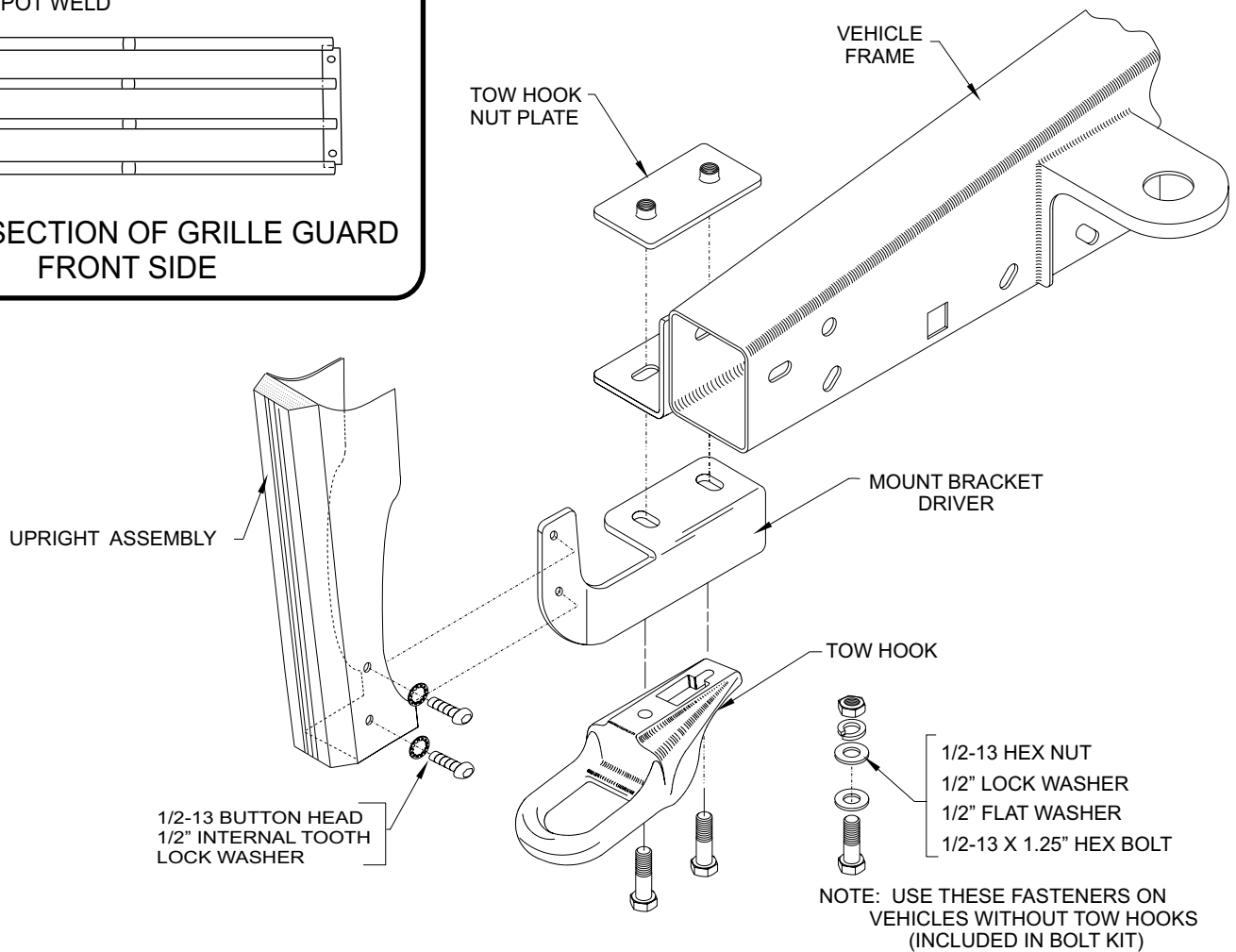

FIGURE 2

**ASSEMBLY AND INSTALLATION VIEW OF DRIVER SIDE
(PASSENGER OPPOSITE)**

Finish protection - Westin products have a high quality finish that must be cared for like any other exposed finish on the vehicle. Protect the finish with a non-abrasive automotive wax (pure carnauba, for example) on a regular basis. The use of cleaner wax or any compound which contains an abrasive is detrimental, as the compounds scratch the finish and open it to corrosion.



Westin Automotive Products, Inc.
5200 N. Irwindale Ave. Suite 220
Irwindale, Ca. 91706

Thank You for choosing Westin products
For additional installation assistance please call
Customer service (800) 793-7846 or (507) 375-3559