



# INSTALLATION INSTRUCTIONS

APPLICATION: 1997-UP FORD EXPEDITION

## AUTOMOTIVE PRODUCTS, INC.

### STEP BAR ASSEMBLIES

25-0925  
25-0930  
26-0925  
26-0930

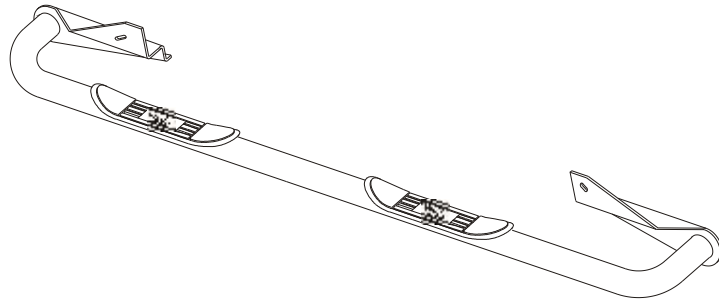

QTY	PARTS KIT CONTENTS DESCRIPTION	TOOLS REQUIRED
1	STEP BAR, DRIVER SIDE	1/2" SOCKET
1	STEP BAR, PASSENGER SIDE	9/16" SOCKET
1	FRONT MOUNT BRACKET, DRIVER SIDE	3/4" SOCKET
1	FRONT MOUNT BRACKET, PASSENGER SIDE	3/4" COMBINATION WRENCH
1	REAR MOUNT BRACKET, DRIVER SIDE	9/16" COMBINATION WRENCH
1	REAR MOUNT BRACKET, PASSENGER SIDE	RATCHET
4	1/2 -13 X 2.00" HEX HEAD BOLT, FLAT WASHER AND LOCK WASHER	TORQUE WRENCH
8	3/8 -16 X 1" HEX HEAD BOLT, LOCK WASHER AND HEX NUT	
4	5/16 -18 X 1" HEX WASHER HEAD, SELF TAPPING BOLT	
16	3/8" FLAT WASHER	
NOTE: FASTENERS ARE CONTAINED IN BOLT KIT 60-1137.		

- STEP 1. Remove the contents from the box and check for any damage. Verify all parts against parts list.
- STEP 2. Read and understand instructions completely before beginning installation.
- STEP 3. Remove black tape over two holes on inside face of rocker panel. See Figure 2.
- STEP 4. Install front mount bracket (See Figure 1) (with downward sloping end towards front) using (2) 3/8-16 x 1.00" hex head bolts, (4) 3/8" flat washers, (2) 3/8" lock washers and (2) 3/8-16 hex nuts. Place bolts through holes as shown in Figure 2. Leave loose.
- STEP 5. Install rear mount bracket (See Figure 1) (with downward sloping end towards rear) using (2) 3/8-16 x 1.00" hex head bolts, (4) 3/8" flat washers, (2) 3/8" lock washers, (2) 3/8" hex nuts. Place bolts through holes in body as shown in Figure 2. Leave loose.
- STEP 6. Install self tapping bolts with 1/2" socket into holes previously covered by factory tape. NOTE: Do not use air tool on this fastener.

STEP 7. Place step bar tube up to front and rear mount brackets and fasten with (2) 1/2-13 x 2.00" hex head bolts, (2) 1/2" flat washer and (2) 1/2" lock washer. Finger Tighten.

STEP 8. Check to be sure step bar is properly aligned with vehicle. Torque 1/2" Fasteners 65 FT LBS; 3/8" Fasteners 35 FT. LBS and 5/16" Fasteners 15 FT. LBS.

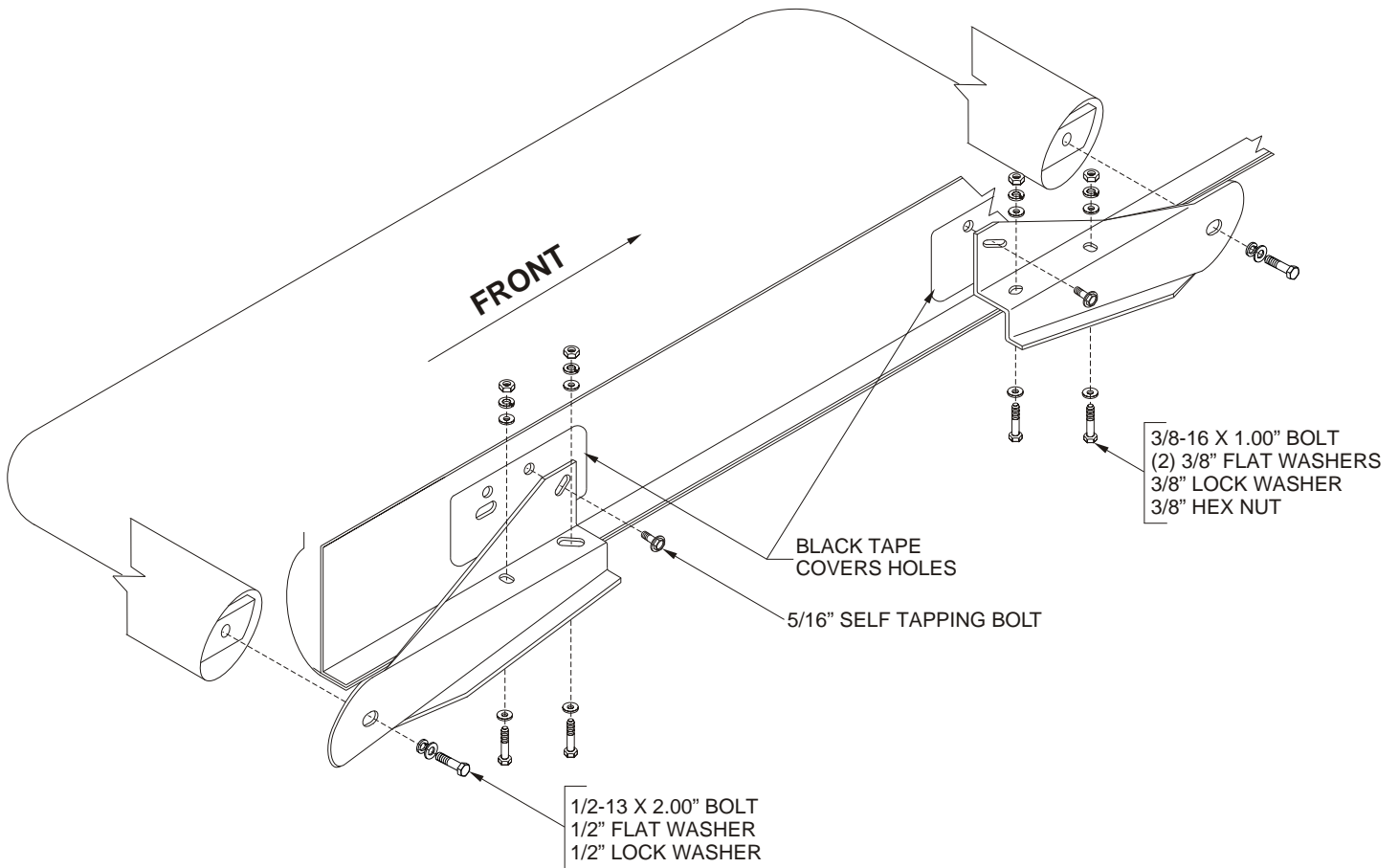
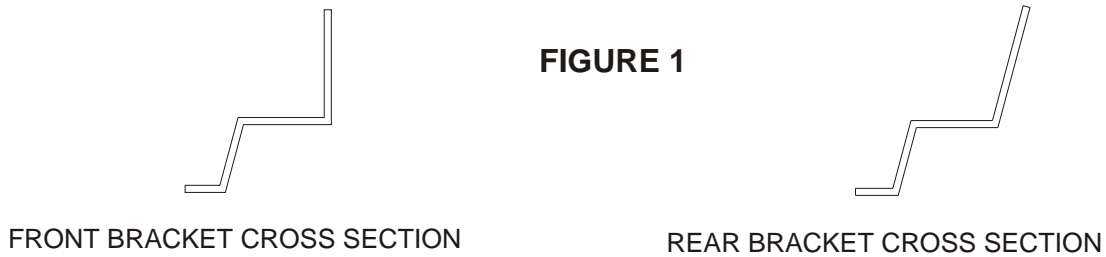

**FIGURE 2**  
**INSTALLATION VIEW OF DRIVER SIDE, PASSENGER SIDE OPPOSITE**

\* PATENT  
PENDING

Finish protection - Westin products have a high quality finish that must be cared for like any other exposed finish on the vehicle. Protect the finish with a non-abrasive automotive wax (pure carnauba, for example) on a regular basis. The use of cleaner wax or any compound which contains an abrasive is detrimental, as the compounds scratch the finish and open it to corrosion.

\* MOUNTING CONFIGURATION ONLY



Westin Automotive Products, Inc.  
5200 N. Irwindale Ave. Suite 220  
Irwindale, Ca. 91706

Thank You for choosing Westin products  
For additional installation assistance please call  
Customer service (800) 793-7846 or (507) 375-3559