

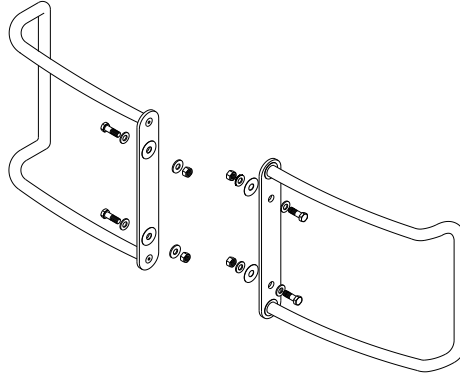

INSTALLATION INSTRUCTIONS

APPLICATION: ALL BRUSH GUARDS

AUTOMOTIVE PRODUCTS, INC.



QTY	PARTS KIT CONTENTS		TOOLS REQUIRED
	DESCRIPTION		
1	BRUSH GUARD WING - PASSENGER SIDE		3/4" SOCKET 3/4" WRENCH RATCHET 3/16" HEX WRENCH (ALLEN) TORQUE WRENCH
1	BRUSH GUARD WING - DRIVER SIDE		
2	WING MOUNT PLATE		
4	1/2-13 X 1.25" HEX HEAD BOLT		
4	.03" X .875" ID X 1.375" OD NYLON FLAT WASHER		
4	1.25" OD POLY WASHER		
4	5/16-18 X 1.50" SS FLATHEAD BOLT		
8	1/2" FLAT WASHER		
4	1/2-13 NYLON INSERT LOCKNUT		

- STEP 1. Remove the contents from the box and check for any damage. Verify all parts against the parts list.
- STEP 2. Read and understand instructions completely before beginning installation.
- STEP 3. Determine Driver and Passenger Wings. (Wings are oriented so the angle on the end of the wing follows the profile of the turn lamp).
- STEP 4. Fasten Wing Mounting Plate to each wing using (2) 5/16-18 X 1.50" SS Flathead Bolts, and (2) .03" X .875" ID X 1.375" OD Nylon Flat Washers. Assemble so raised side of Mount Plate is toward the Wing, and the nylon flat washers are between the Mount Plate and the Wing. Tighten and torque the Flathead bolts to 20 Ft. Lbs.
Note: When attaching the Wing Mount Plate to the Wing, orientate the Wing Mount Plate to Wing so the top of the Wing Mount Plate is the end with the larger distance between holes.
- STEP 5. Fasten Wing and Mount Plate Assembly to Push Bar Upright using (2) 1/2-13 x 1.25" Hex Head Bolts, (4) 1/2" Flat Washers, (2) 1 3/4" OD Poly Washers. And (2) 1/2-13 Nylon insert Locknuts per assembly. Tighten and torque these fasteners to 60 Ft. Lbs.

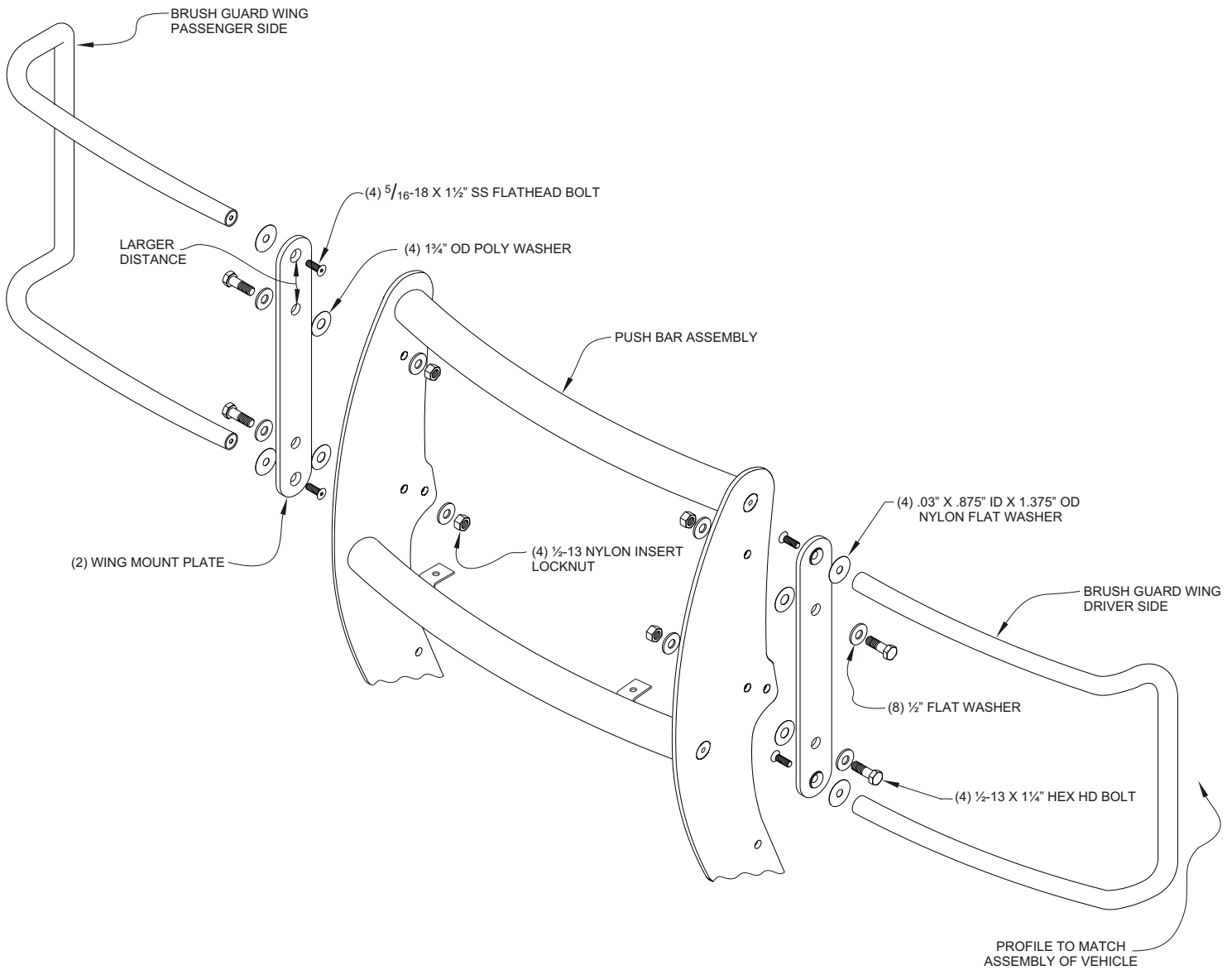

Finish protection - Westin products have a high quality finish that must be cared for like any other exposed finish on the vehicle. Protect the finish with a non-abrasive automotive wax (pure carnauba, for example) on a regular basis. The use of cleaner wax or any compound which contains an abrasive is detrimental, as the compounds scratch the finish and open it to corrosion.



Westin Automotive Products, Inc.
 5200 N. Irwindale Ave. Suite 220
 Irwindale, Ca. 91706

Thank You for choosing Westin products
 For additional installation assistance please call
 Customer service (800) 793-7846 or (507) 375-3559