



# INSTALLATION INSTRUCTIONS

APPLICATION: 1982-90 MID GM  
 1981-97 GM C/K SERIES PICK-UP  
 1981-91 GM C/K SERIES SPORT UTILITY

**AUTOMOTIVE PRODUCTS, INC.**

PUSH BAR  
 ASSEMBLY

**36-1065**  
**36-1075**  
**36-1180**

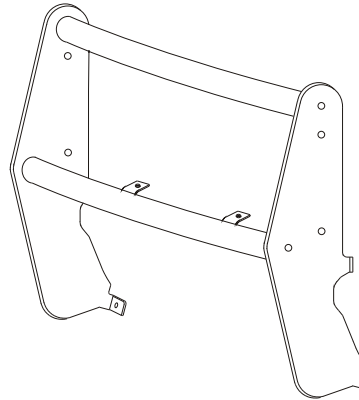

QTY	PARTS KIT CONTENTS DESCRIPTION	TOOLS REQUIRED
1	FORMED UPRIGHT, PASSENGER	9/16" SOCKET 5/16" HEX WRENCH (ALLEN) 3/8" WRENCH RATCHET
1	FORMED UPRIGHT, DRIVER	
1	BOTTOM TUBE ASSEMBLY	
1	TOP TUBE ASSEMBLY	
2	BUMPER CLAMP	
2	BUMPER CLAMP	
2	LIGHT MOUNT	
4	1/2-13 X 1.50" FLAT HEAD BOLT	
4	3/8-16 X 1.00" HEX HEAD BOLT	
4	3/8-16 HEX NUT	
4	3/8" SPLIT LOCK WASHER	
4	3/8" SAE FLAT WASHER	
2	3/8-16 X 1.00" SELF THREADING BOLT	
2	7/16" IS NYLON WASHER	
4	3.00" POLY WASHER	

- STEP 1. Remove the contents from the box and check for any damage. Verify all parts against the parts list.
- STEP 2. Read and understand instructions completely before beginning installation.
- STEP 3. Fasten Light Mounts to Bottom Tube using (2) 3/8-16 x 1.00" Self Threading Bolt and (2) 7/16" ID Nylon Washers. Tighten and torque to 20 FT. LBS. **See Figure 1.**
- STEP 4. Determine Driver and Passenger Uprights and Top and Bottom Tubes. (Uprights are positioned so raised side of bolt holes are facing each other and the tube with the two pierced holes is the Bottom Tube).
- STEP 5. Fasten Uprights to Top and Bottom Tubes using (4) 1/2-13 x 1.50" Flat Head Bolts and (4) 3.00" OD Poly Washers. Finger tighten.

STEP 6. Mount Top Clamp to Uprights using 3/8-16 x 1.00" Hex Head Bolt and 3/8" Flat Washers, Thread to about 3 to 4 turns.

STEP 7. Position Push Bar up to bumper and hook Top Clamps on back edge of bumper. Mount Bottom Clamps to Uprights and hook on back edge of bumper. Finger tighten.

NOTE: On models with air dam to mount Bottom Clamp, loosen air dam to allow clamp to fit between bumper and air dam. Retighten air dam after Push Bar installation is complete.

STEP 8. Adjust Push Bar to center of vehicle and tighten all bolts until Push Bar feels secure.

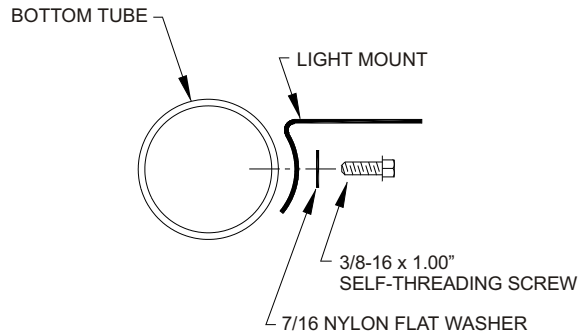

FIGURE 1

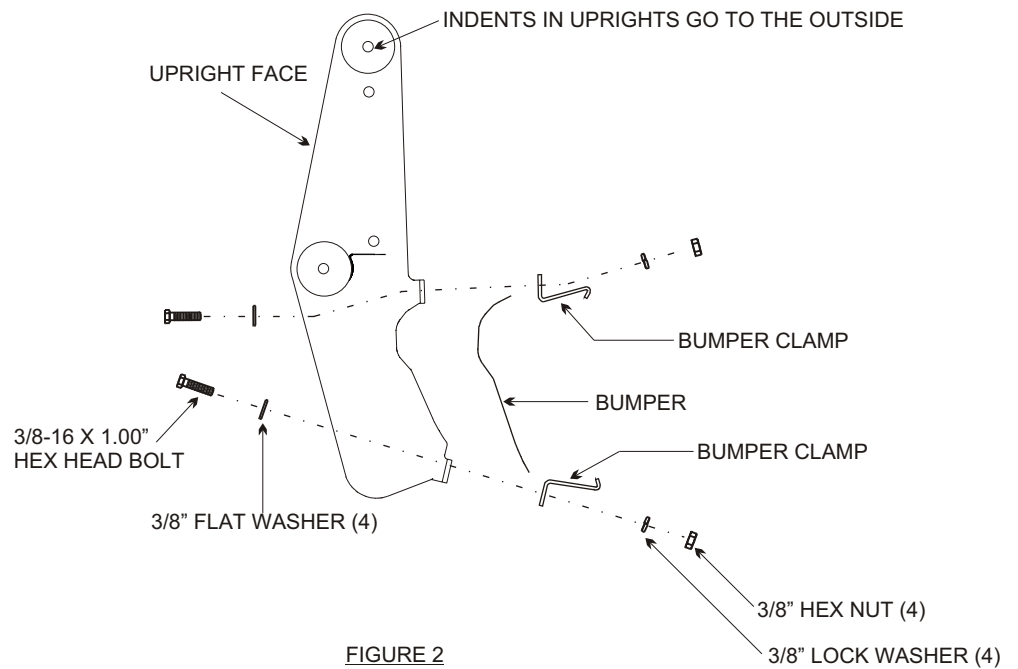

FIGURE 2

Finish protection - Westin products have a high quality finish that must be cared for like any other exposed finish on the vehicle. Protect the finish with a non-abrasive automotive wax (pure carnauba, for example) on a regular basis. The use of cleaner wax or any compound which contains an abrasive is detrimental, as the compounds scratch the finish and open it to corrosion.