



INSTALLATION INSTRUCTIONS

APPLICATION: '99-03 TOYOTA TUNDRA EXTENDED
(ACCESS) CAB PICK-UP, SHORT BED

AUTOMOTIVE PRODUCTS, INC.

STEP BAR
ASSEMBLIES

24-4090
24-4095

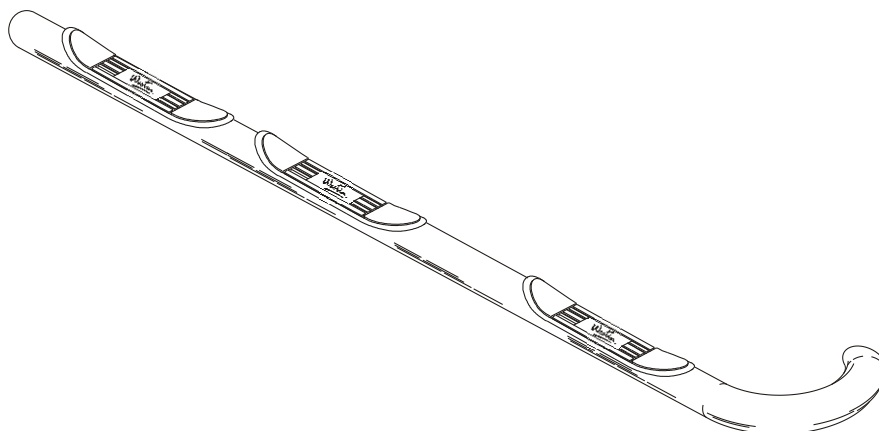

QTY	PARTS KIT CONTENTS		TOOLS REQUIRED
	DESCRIPTION		
1	STEP BAR - PASSENGER SIDE		7/32" ALLEN WRENCH 3/4" SOCKET 3/4" WRENCH RATCHET 6" EXTENSION TORQUE WRENCH
1	STEP BAR - DRIVER SIDE		
1	FRONT BRACKET - PASSENGER		
1	FRONT BRACKET - DRIVER		
2	REAR BRACKETS		
2	FRONT MOUNTING TAB ASSY		
4	3/8-16 X 1.00 BUTTON HEAD BOLT		
4	3/8" FLAT WASHER		
4	3/8" SPLIT LOCK WASHER		
2	1/2-13 X 1.75 HEX HEAD BOLT		
2	1/2 ID X 1.81 OD FLAT WASHER		
6	1/2 FLAT WASHER		
6	1/2 SPLIT LOCK WASHER		

- STEP 1. Remove the contents from the box and check for any damage. Verify all parts against the parts list. Read and understand instructions completely before beginning installation.
- STEP 2. Locate the rectangular holes in the frames towards the front of the vehicle. Insert the Front Mounting Tab Assembly into the hole from the inside of the frame. Attach the Front Mounting Bracket with 1/2" Flat Washer, 1/2" Lock Washer and 1/2-13 Hex Nut. Hand tighten then repeat for opposite side.(See Figure 1)
- STEP 3. Attach the Rear Mounting Bracket with 1/2-13 X 1.75" Hex Head Bolt, 1/2" I.D. X 1.81" O.D. Flat Washer, 1/2" Flat Washer, 1/2" Lock Washer and 1/2-13 Hex Nut. Hand tighten then repeat for opposite side.
Note: Place the 1/2" I.D. X 1.81" O.D. Flat Washer under the head of the Hex Bolt and insert through frame from inside of frame.(See Figure 1)
- STEP 4. Loosely assemble Front of Step Bar to Bracket using 1/2-13 X 1.75" Hex Head Bolt, 1/2" Lock Washer and 1/2" Flat washer.(See Figure 1)

- STEP 5. Loosely assemble Step Bar to Rear Bracket using (2) 3/8-16 X 1.00" Button Head Bolt, 3/8" Lock Washer and 3/8" Flat Washer.(See Figure 1 & 2)
- STEP 6. Repeat steps 5 and 6 for opposite side.
- STEP 7. Check to make sure Step Bars are properly aligned with vehicle, then tighten and torque 1/2" fasteners to 65 Ft. Lbs., and 3/8" fasteners to 32 Ft. Lbs.

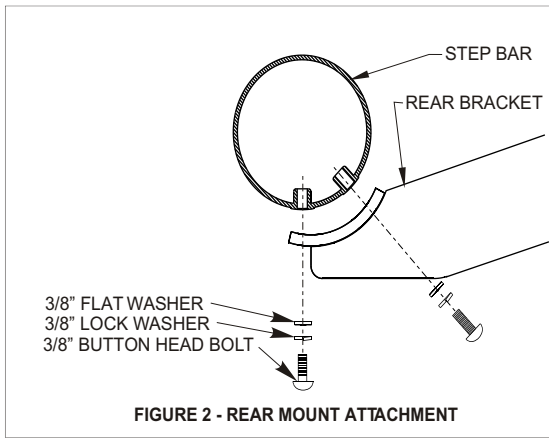
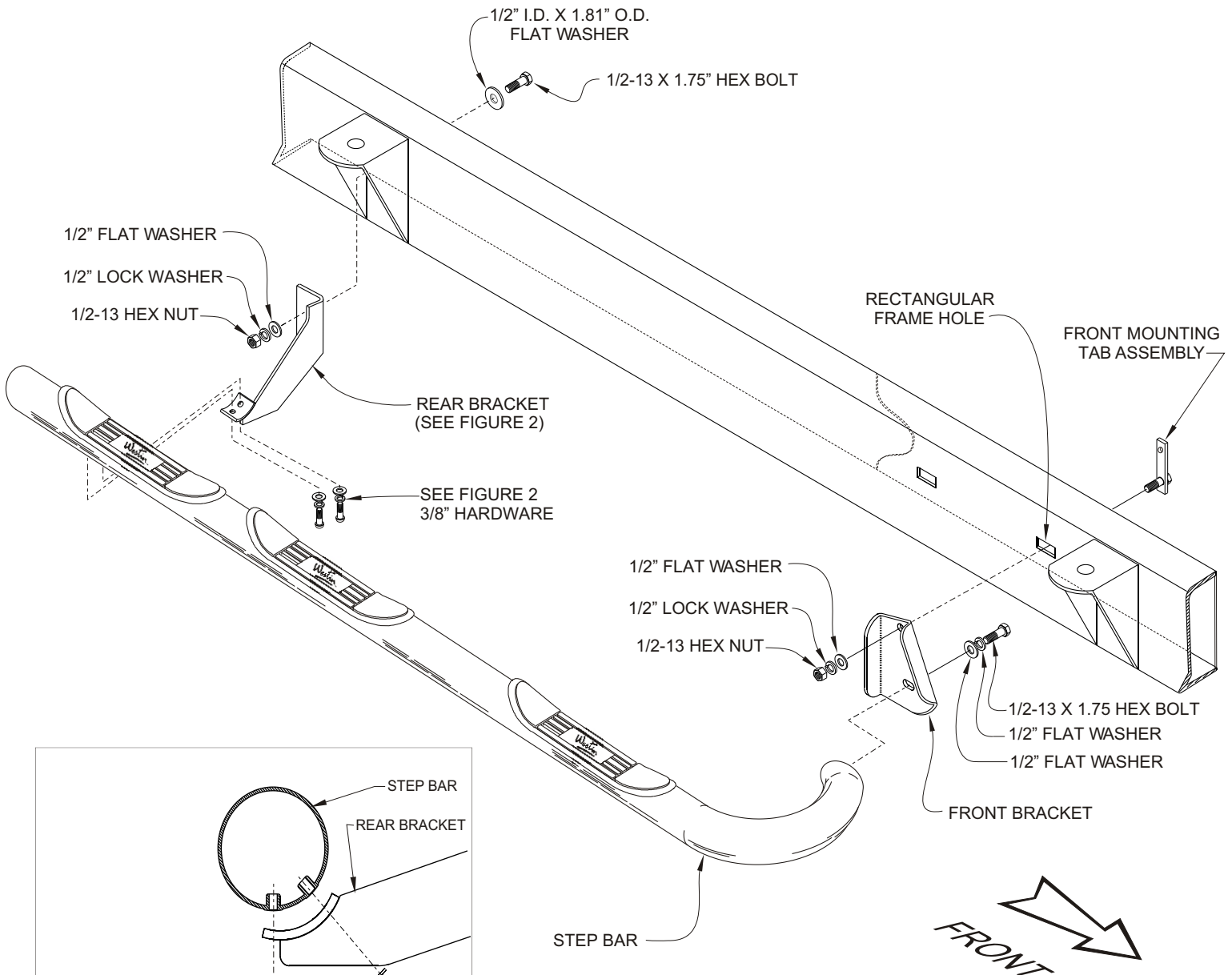

FIGURE 2 - REAR MOUNT ATTACHMENT

FIGURE 1

PASSENGER SIDE INSTALLATION SHOWN - DRIVER SIDE OPPOSITE

Finish protection - Westin products have a high quality finish that must be cared for like any other exposed finish on the vehicle. Protect the finish with a non-abrasive automotive wax (pure carnauba, for example) on a regular basis. The use of cleaner wax or any compound which contains an abrasive is detrimental, as the compounds scratch the finish and open it to corrosion.



Westin Automotive Products, Inc.
5200 N. Irwindale Ave. Suite 220
Irwindale, Ca. 91706

Thank You for choosing Westin products
For additional installation assistance please call
Customer service (800) 345-8476 or (626) 960-6762