



INSTALLATION INSTRUCTIONS

APPLICATION: 1997-UP FORD F150/250 LD SUPER CAB-4DR

AUTOMOTIVE PRODUCTS, INC.

STEP BAR ASSEMBLIES

24-4060
24-4065

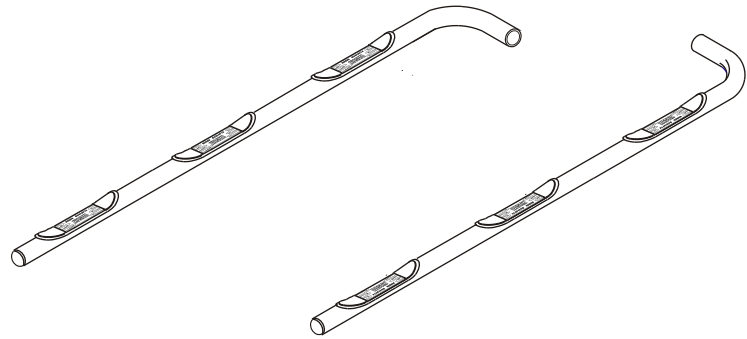

QTY	PART KIT CONTENTS DESCRIPTION	TOOLS REQUIRED
1	STEP BAR - DRIVER SIDE	
1	STEP BAR - PASSENGER SIDE	
1	MOUNT BRACKET, FRONT-DRIVER SIDE	3/4" SOCKET
1	MOUNT BRACKET, FRONT-PASSENGER SIDE	9/16" SOCKET
1	MOUNT BRACKET, REAR-DRIVER SIDE	7/32" HEX BIT SOCKET
1	MOUNT BRACKET, REAR-PASSENGER SIDE	RATCHET
4	BOLTPLATE, LARGE	3/4" WRENCH
1	BOLTPLATE, SMALL ('97-'98 EXT CAB ONLY)	9/16" WRENCH
2	1/2"-13 X 1.75" HEX HEAD BOLT	TORQUE WRENCH
2	1/2" FLAT WASHER	
2	1/2" SPLIT LOCK WASHER	
8	3/8" FLAT WASHER	
8	3/8" SPLIT LOCK WASHER	
8	3/8"-16 HEX NUT	
4	3/8"-16" X 1.25" ALLEN HEAD BOLT-BLACK	
4	3/8" FLAT WASHER-BLACK	
4	3/8" INTERNAL TOOTH LOCK WASHER-BLACK	

- STEP 1.** Remove the contents from the box and check for any damage. Verify all parts against parts list. Read and understand instructions completely before beginning installation.
- STEP 2.** Remove black rubber plugs over two holes (three on '97-'98 ext cab driver side) on each inside face of sheet metal rocker panel. (See figure 1.)
- STEP 3.** Install front mounting brackets by placing bolt plate (large) through hole in body as shown (See Figure 2). Position front bracket with downward sloping end towards front of truck. Assemble with 3/8" flat washers, lock washers and hex nuts. (See Figure 3). Leave loose.
- STEP 4.** Install rear mounting brackets by placing bolt plate (large) through hole in body as shown (See Figure 2). Assemble with 3/8" flat washers, lock washers and hex nuts. (See Figure 3). Leave loose.
NOTE: '97-'98 Extended Cab driver side rear bracket uses small bolt plate. This uses the two lower holes in the rear bracket (See Figure 3).
- STEP 5.** Place Step Bar tube up to front and rear brackets and loosely fasten at the front with 1/2" hardware and at the rear with 3/8" hardware (See Figure 4).
- STEP 6.** Check to make sure Step Bar is level and properly aligned to truck. Tighten and torque 1/2" hardware to 65 ft-lbs., 3/8" hardware to 30 ft-lbs.

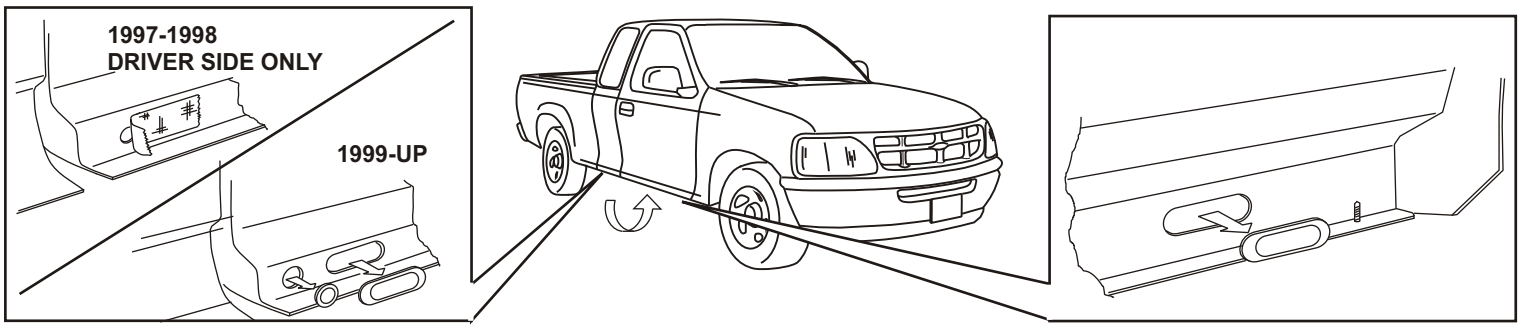

FIGURE 1 - PASSENGER SIDE SHOWN, DRIVER SIDE OPPOSITE

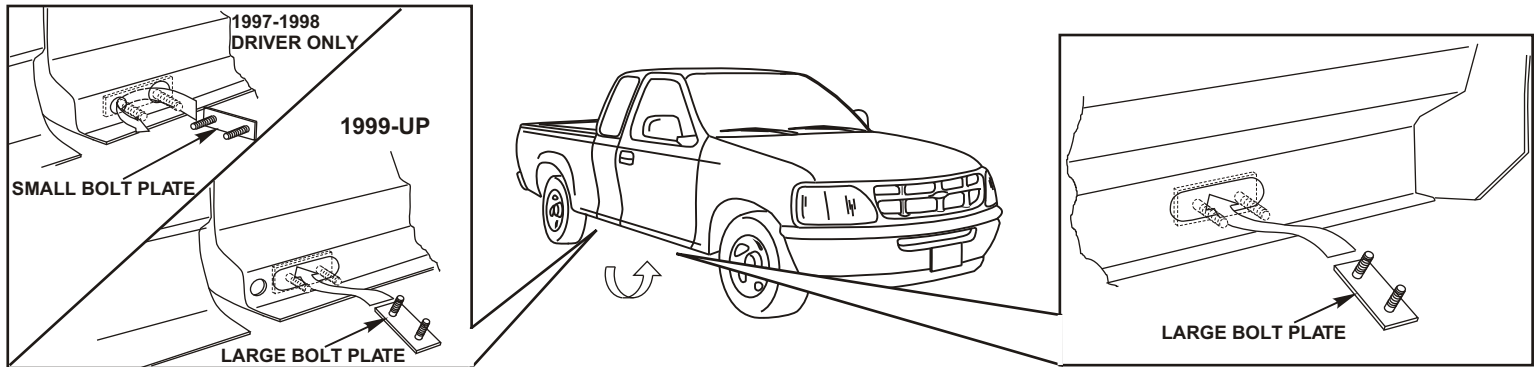

FIGURE 2 - PASSENGER SIDE SHOWN, DRIVER SIDE OPPOSITE

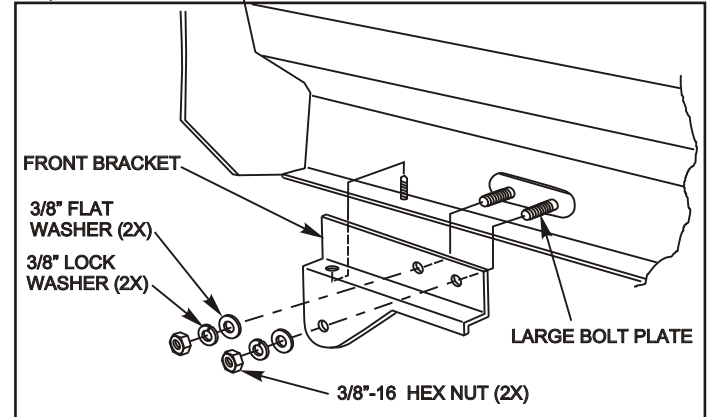
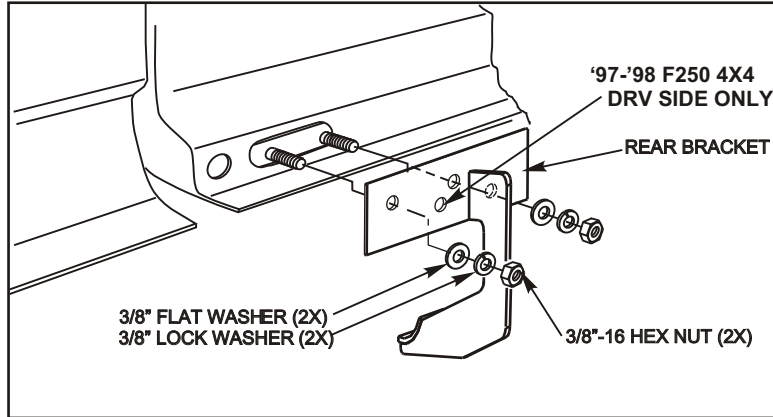

FIGURE 3 - PASSENGER SIDE SHOWN, DRIVER SIDE OPPOSITE

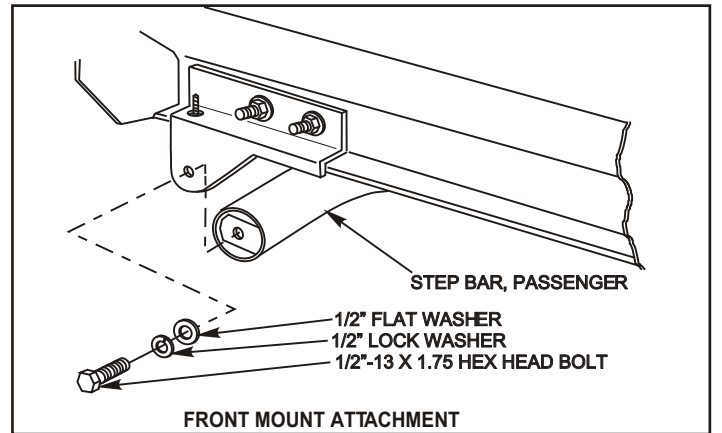
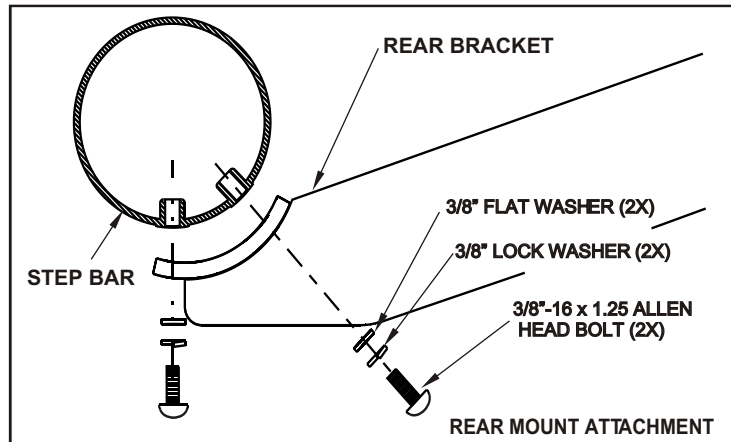

FIGURE 4 - PASSENGER SIDE SHOWN, DRIVER SIDE OPPOSITE

Finish protection - Westin products have a high quality finish that must be cared for like any other exposed finish on the vehicle. Protect the finish with a non-abrasive automotive wax (pure carnauba, for example) on a regular basis. The use of cleaner wax or any compound which contains an abrasive is detrimental, as the compounds scratch the finish and open it to corrosion.



Westin Automotive Products, Inc.
5200 N. Irwindale Ave. Suite 220
Irwindale, Ca. 91706

AUTOMOTIVE PRODUCTS, INC.

Thank You for choosing Westin products
For additional installation assistance please call
Customer service (800) 793- 7846 or (507) 375-3559