



INSTALLATION INSTRUCTIONS

APPLICATION: '88-99* CHEVY/GMC EXTENDED CAB PICK-UP, SHORTBED.

(*Does not fit new SILVERADO/SIERRA body styles sold in '99)

AUTOMOTIVE PRODUCTS, INC.

STEP BAR
ASSEMBLIES

24-4100
24-4105

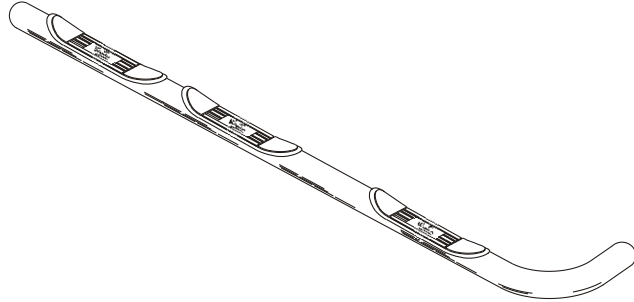

QTY	PARTS KIT CONTENTS		TOOLS REQUIRED
	DESCRIPTION		
1	STEP BAR - PASSENGER SIDE		7/32" ALLEN WRENCH
1	STEP BAR - DRIVER SIDE		3/4" SOCKET
2	FRONT BRACKETS		3/4" WRENCH
1	REAR BRACKET - DRIVER		RATCHET
1	REAR BRACKET - PASSENGER		6" EXTENSION
1	REAR SUPPORT BRACKET - DRIVER		TORQUE WRENCH
1	REAR SUPPORT BRACKET - PASSENGER		9/16" SOCKET
8	1/2" FLAT WASHER		9/16" WRENCH
2	1/2-13 X 1.75 HEX HEAD BOLT		
4	1/2" SPLIT LOCK WASHER		
2	1/2" HEX NUT		
4	3/8-16 X 1.00 BUTTON HEAD BOLT		
8	3/8" FLAT WASHER		
6	3/8" SPLIT LOCK WASHER		
2	3/8-16 X 1.00 HEX HEAD BOLT		
2	3/8" HEX NUT		

- STEP 1. Remove the contents from the box and check for any damage. Verify all parts against the parts list. Read and understand instructions completely before beginning installation.
- STEP 2. Remove Front passenger side Body Mount Bolt. Attach Front Bracket using previously removed Stock Bolt and supplied 1/2" Flat Washer. Be sure to reinstall factory Body Mount Rubber and Washer. Hand Tighten only. (See Figure 1)
- STEP 3. Remove Rear passenger side body Mount Bolt. Attach Rear Bracket using previously removed Stock Bolt and supplied 1/2" Flat washer. Be sure to reinstall factory Body Mount Rubber and Washer. Hand Tighten only. (See Figure 1)
- STEP 4. For Rear Support Strap- remove rubber grommet from inside of body. Insert supplied Stud Plate. Attach passenger side Support Strap to Stud Plate using 1/2" Lock Washer, 1/2" Flat Washer and 1/2" Hex Nut.. (See Figure 3)
- STEP 5. Attach Rear Bracket to Support Strap using 3/8" Hex Head Bolt,(2) 3/8" Washers, 3/8" Lock Washer and 3/8" Hex Nut. Hand Tighten only. (See Figure 1)
- STEP 6. Loosely assemble Front of Step Bar to Bracket using 1/2-13 X 1.75" Hex Head Bolt, 1/2" Lock Washer and 1/2" Flat Washer. (See Figure 1)

- STEP 7. Loosely assemble Step Bar to Rear Bracket using (2) 3/8-16 X 1.00" Button Head Bolt, 3/8" Lock Washer and 3/8" Flat Washer. (See Figure 1 & 2)
- STEP 8. Check to make sure Step Bar is properly aligned with vehicle, then tighten and torque 1/2" fasteners to 65 Ft. Lbs., and 3/8" fasteners to 32 Ft. Lbs.
- STEP 9. Repeat steps 2-8 for Driver Side.

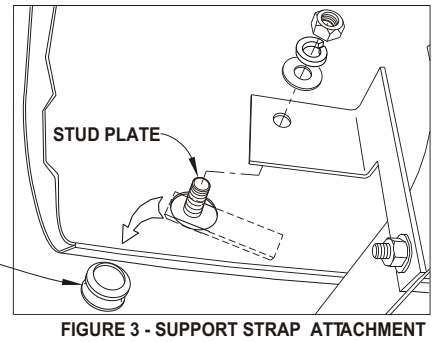
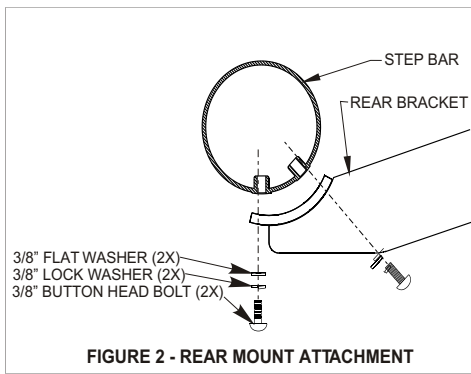
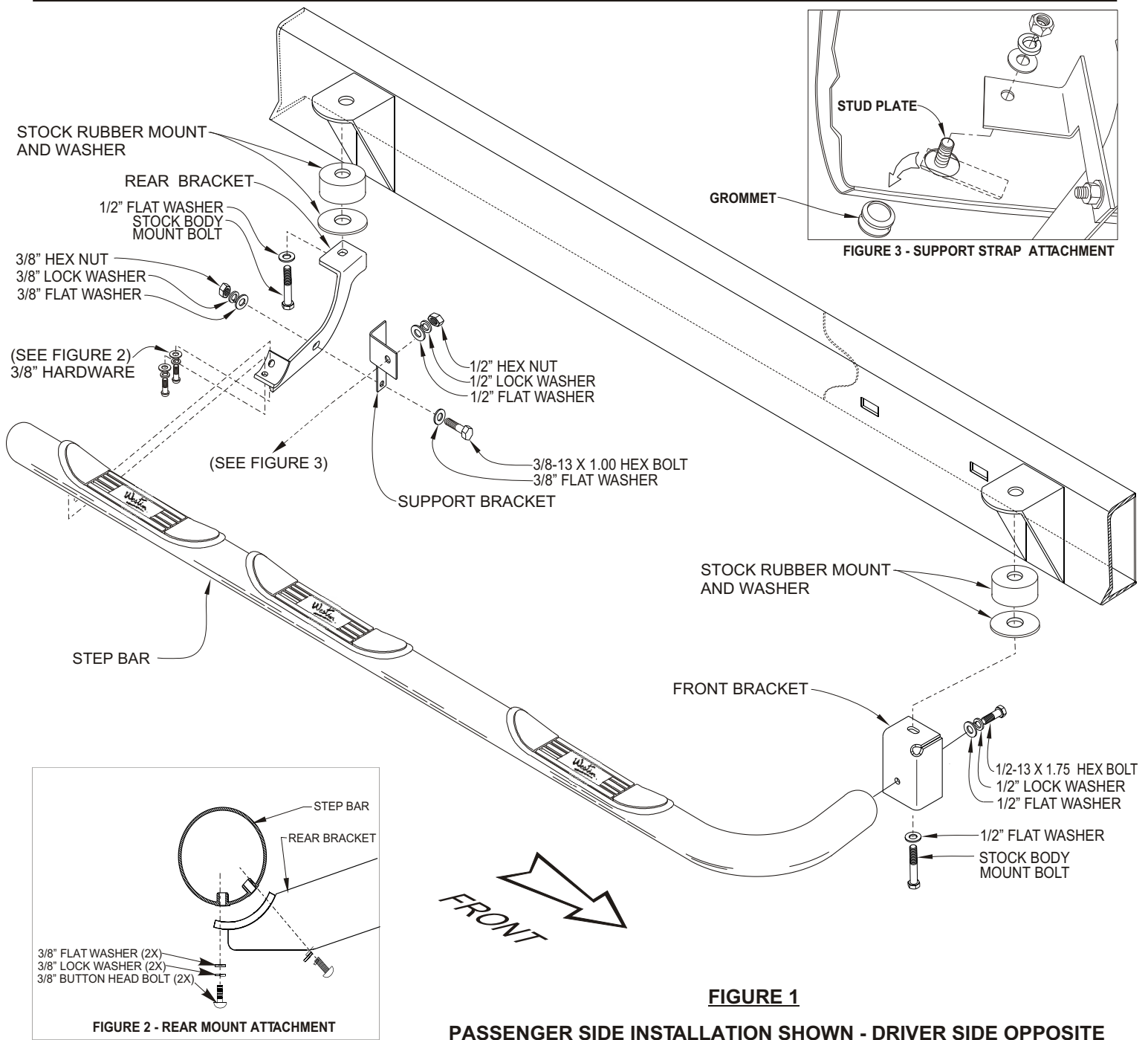

Finish protection - Westin products have a high quality finish that must be cared for like any other exposed finish on the vehicle. Protect the finish with a non-abrasive automotive wax (pure carnauba, for example) on a regular basis. The use of cleaner wax or any compound which contains an abrasive is detrimental, as the compounds scratch the finish and open it to corrosion.



Westin Automotive Products, Inc.
5200 N. Irwindale Ave. Suite 220
Irwindale, Ca. 91706

Thank You for choosing Westin products
For additional installation assistance please call
Customer service (800) 345-8476 or (626) 960-6762



WESTIN

Premium Quality Truck Accessories

WESTIN WARRANTY

FIVE YEAR WARRANTY FOR STEP BOARDS, POWDER COATED STEEL & CHROME PLATED STEEL PRODUCTS

Westin Automotive Products, Inc. guarantees the original purchaser of Westin Signature Series Step Bars, Classic Grille Guards, Push Bars, Brush Guards, Sportsman One-Piece Grille Guards, Tail Light Guards, Step Boards and Trailblazer bumpers a five-year warranty from the date of original purchase against manufacturer defects in materials, workmanship and finish under normal use excluding damage resulting from road hazards such as gravel or other debris, product misuse, improper installation, impairments from accidents, product modifications or product neglect. This five year warranty applies only to new products and is limited to the repair or replacement of Westin products. Warranty does not include electrical components or light bulb replacement, costs of removal, installation, labor, inconvenience or consequential damages. Original purchaser must return defective merchandise, along with the purchase receipt, to the original place of purchase.

LIFETIME WARRANTY FOR BLACK POWDERCOAT AND CHROME PLATED STAINLESS STEEL PRODUCTS

Westin Automotive Products, Inc. guarantees the original purchaser of Platinum Series™ Step Bars, Chrome-plated Stainless Steel Safari Light Bars and Sportsman Modular Grille Guards a lifetime warranty against manufacturer defects in materials, workmanship and finish under normal use excluding damage resulting from road hazards such as gravel or other debris, product misuse, improper installation, impairments from accidents, product modifications or product neglect. This lifetime warranty applies only to new products and is limited to the repair or replacement of Westin products. Warranty does not include costs of removal, installation, labor, inconvenience or consequential damages. Original purchaser must return defective merchandise, along with the purchase receipt, to the original place of purchase.

FINISH PROTECTION

Westin products have a high quality finish that must be cared for like any other exposed finish on the vehicle. Protect the finish with a non-abrasive automotive wax, (e.g. Pure Carnauba) on a regular basis. The use of any soap, polish or wax that contains an abrasive is detrimental, as the compounds scratch the finish and open it to corrosion.

DISCLAIMER FOR WESTIN PRODUCTS

Buyer assumes all risk and liability whatsoever from the installation and use of Westin products. Westin products are sold as decorative accessories and should not be relied upon as protection for the vehicle or occupants in the event of a collision or roll over. Vehicles equipped with a supplemental restraints system (air bags) deployed by impact should not be modified by any aftermarket Grille Guard, Push Bar, Light Bar or Bull Bar without first consulting the vehicle manufacturer. Westin Automotive Products, Inc. assumes no liability for injury, loss, incidental or consequential damages in the event of a collision or roll over.