



SIGNATURE OF QUALITY

AUTOMOTIVE PRODUCTS, INC.

"L" BRACKET INSTALLATION GUIDE

QTY	PARTS KIT CONTENTS DESCRIPTION	TOOLS REQUIRED
2	"L" BRACKETS	7/32" DRILL BIT
10	PHILLIPS HEAD BOLTS	PHILLIPS HEAD SCREWDRIVER
10	HEX NUTS	DRILL
10	LOCK WASHERS	10MM WRENCH

FOR TOYOTA, NISSAN, CHEVY S-10 and GMC up to '94, and MAZDA up to '94

- Step 1. Remove contents from box and check for any damage. Verify all parts against the parts list. Read and understand instructions completely before beginning installation.
- Step 2. Position and hold template on passenger side flange on truck bed. (see Figure 1)
- Step 3. Using a center punch, punch each hole. If the truck has a bed liner, center punch the bed liner. **DO NOT CUT THE BED LINER!**
- Step 4. Drill mounting holes using 7/32" drill.
- Step 5. Install Quick Latch brackets onto "L" brackets. Levers need to face tailgate. (see Figure 2)
- Step 5. Install "L" bracket.
- Step 6. Repeat steps 2-5 for driver's side.

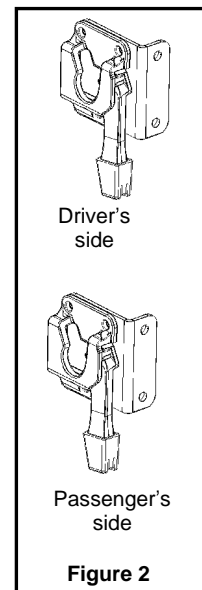
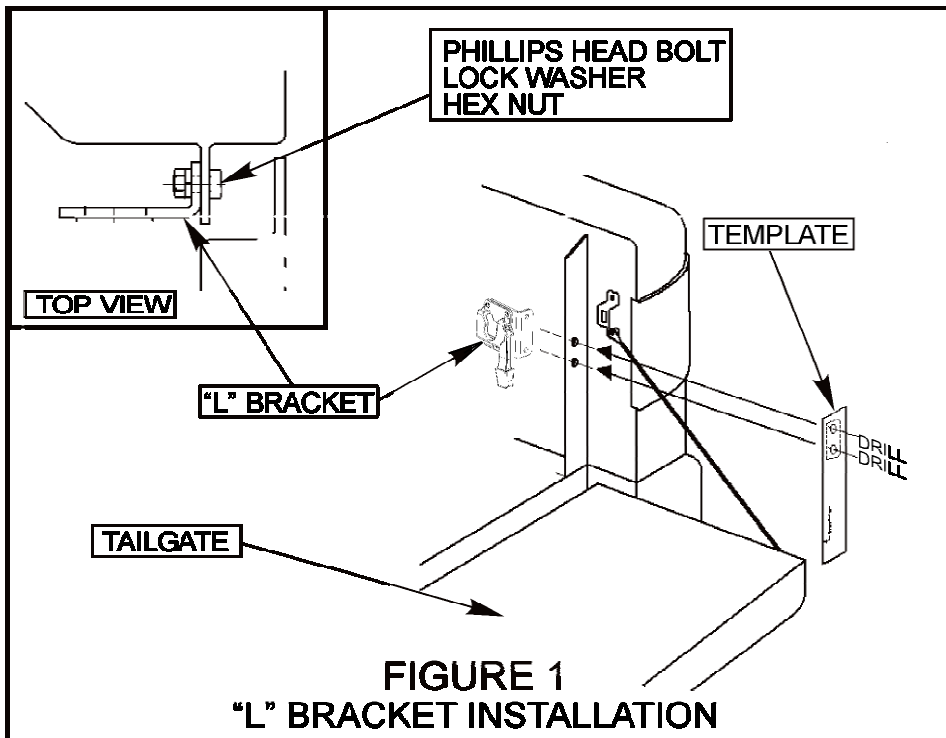
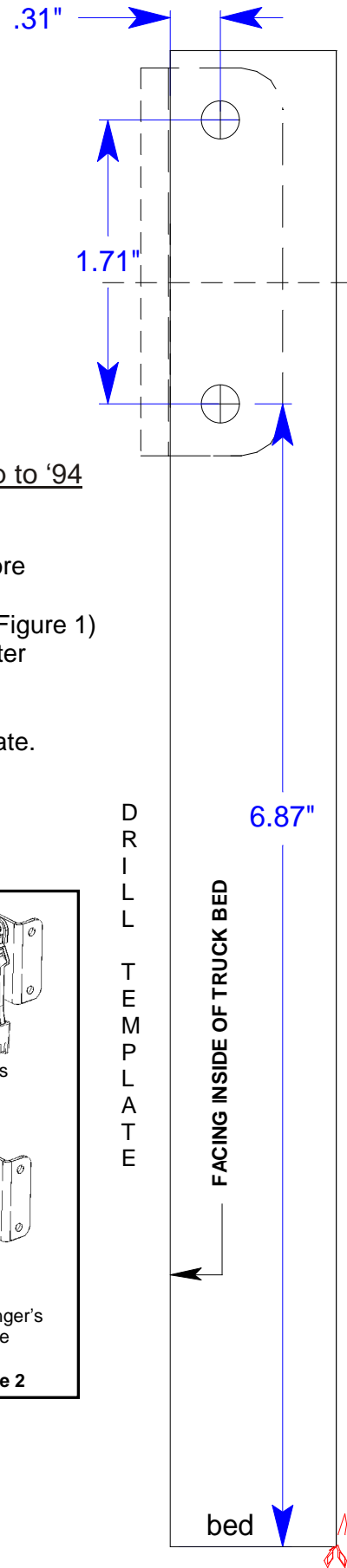

PASSENGER SIDE SHOWN, DRIVER SIDE OPPOSITE